

EcoStruxure™ Control Expert

Applicative Time Stamping

User Guide

Original instructions

EIO0000001268.05
02/2022

Legal Information

The Schneider Electric brand and any trademarks of Schneider Electric SE and its subsidiaries referred to in this guide are the property of Schneider Electric SE or its subsidiaries. All other brands may be trademarks of their respective owners.

This guide and its content are protected under applicable copyright laws and furnished for informational use only. No part of this guide may be reproduced or transmitted in any form or by any means (electronic, mechanical, photocopying, recording, or otherwise), for any purpose, without the prior written permission of Schneider Electric.

Schneider Electric does not grant any right or license for commercial use of the guide or its content, except for a non-exclusive and personal license to consult it on an "as is" basis. Schneider Electric products and equipment should be installed, operated, serviced, and maintained only by qualified personnel.

As standards, specifications, and designs change from time to time, information contained in this guide may be subject to change without notice.

To the extent permitted by applicable law, no responsibility or liability is assumed by Schneider Electric and its subsidiaries for any errors or omissions in the informational content of this material or consequences arising out of or resulting from the use of the information contained herein.

As part of a group of responsible, inclusive companies, we are updating our communications that contain non-inclusive terminology. Until we complete this process, however, our content may still contain standardized industry terms that may be deemed inappropriate by our customers.

Table of Contents

| | |
|---|-----------|
| Safety Information | 5 |
| Before You Begin..... | 6 |
| Start-up and Test..... | 7 |
| Operation and Adjustments | 8 |
| About the Book | 9 |
| Introduction to Applicative Time Stamping | 11 |
| Presentation | 12 |
| Applicative Time Stamping Concepts | 12 |
| Applicative Time Stamping Limitations | 13 |
| Applicative Time Stamping Architecture | 15 |
| Components | 16 |
| Time Synchronization | 16 |
| Control Expert Software | 16 |
| BMX ERT 1604 T Module..... | 17 |
| BMX CRA 312 10 Module | 17 |
| 140 ERT 854 •0 Module | 18 |
| Components Versions | 20 |
| Components Version | 20 |
| Architecture Examples..... | 21 |
| Time Stamping Typical Architecture | 21 |
| Performances | 26 |
| Components and System | 26 |
| Design and Configuration Phases for Modicon M340 Modules | 28 |
| Applicative Time Stamping Service Activation..... | 29 |
| Applicative Time Stamping Service Configuration | 29 |
| Control Expert Project Settings..... | 30 |
| Selecting the Appropriate Time Stamping Module | 32 |
| Time Resolution | 32 |
| Selecting and Setting Time Synchronization | 34 |
| Selecting the Time Source..... | 34 |
| Control Expert Project Setting..... | 36 |
| BMX ERT 1604 T Clock Settings | 36 |

- BMX CRA 312 10 Clock Settings 37
- Selecting and Configuring the Variables to Time Stamp 39
 - Variables Usage 39
 - BMX ERT 1604 T Settings 39
 - BMX CRA 312 10 Settings 42
- User Application 45
 - GET_TS_EVT_M application examples 45
 - GET_TS_EVT_Q application examples 47
 - Applicative Time Stamping Functions Representation 50
- Commissioning and Operation Phases for Modicon M340 Modules 52
 - Diagnostic 53
 - Time Stamping Modules Diagnostic 53
 - Data Diagnostic 54
 - Hardware Diagnostic 56
 - Behavior on Operating Modes 59
 - Introduction 59
 - Start and Power Down/up of a Time Stamping Module 61
 - Replacement of a Time Stamping Module 61
 - Behavior on Buffer Full 62
 - Behavior on Time Synchronization 65
 - Time Synchronization 65
 - Run Time Behavior 68
 - Function Blocks Programming Rules 68
 - Event Time Stamp Entry 72
- Quantum Modules for Applicative Time Stamping 75
 - 140 ERT 854 •0 Modules Implementation 76
 - 140 ERT 854 •0 Modules 76
- Appendices 77
 - Error Codes 78
 - Error Codes 78
- Glossary 79
- Index 83

Safety Information

Important Information

Read these instructions carefully, and look at the equipment to become familiar with the device before trying to install, operate, service, or maintain it. The following special messages may appear throughout this documentation or on the equipment to warn of potential hazards or to call attention to information that clarifies or simplifies a procedure.



The addition of this symbol to a “Danger” or “Warning” safety label indicates that an electrical hazard exists which will result in personal injury if the instructions are not followed.



This is the safety alert symbol. It is used to alert you to potential personal injury hazards. Obey all safety messages that follow this symbol to avoid possible injury or death.

DANGER

DANGER indicates a hazardous situation which, if not avoided, **will result in** death or serious injury.

WARNING

WARNING indicates a hazardous situation which, if not avoided, **could result in** death or serious injury.

CAUTION

CAUTION indicates a hazardous situation which, if not avoided, **could result in** minor or moderate injury.

NOTICE

NOTICE is used to address practices not related to physical injury.

Please Note

Electrical equipment should be installed, operated, serviced, and maintained only by qualified personnel. No responsibility is assumed by Schneider Electric for any consequences arising out of the use of this material.

A qualified person is one who has skills and knowledge related to the construction and operation of electrical equipment and its installation, and has received safety training to recognize and avoid the hazards involved.

Before You Begin

Do not use this product on machinery lacking effective point-of-operation guarding. Lack of effective point-of-operation guarding on a machine can result in serious injury to the operator of that machine.

▲ WARNING

UNGUARDED EQUIPMENT

- Do not use this software and related automation equipment on equipment which does not have point-of-operation protection.
- Do not reach into machinery during operation.

Failure to follow these instructions can result in death, serious injury, or equipment damage.

This automation equipment and related software is used to control a variety of industrial processes. The type or model of automation equipment suitable for each application will vary depending on factors such as the control function required, degree of protection required, production methods, unusual conditions, government regulations, etc. In some applications, more than one processor may be required, as when backup redundancy is needed.

Only you, the user, machine builder or system integrator can be aware of all the conditions and factors present during setup, operation, and maintenance of the machine and, therefore, can determine the automation equipment and the related safeties and interlocks which can be properly used. When selecting automation and control equipment and related software for a particular application, you should refer to the applicable local and national standards and regulations. The National Safety Council's Accident Prevention Manual (nationally recognized in the United States of America) also provides much useful information.

In some applications, such as packaging machinery, additional operator protection such as point-of-operation guarding must be provided. This is necessary if the operator's hands and other parts of the body are free to enter the pinch points or other hazardous areas and

serious injury can occur. Software products alone cannot protect an operator from injury. For this reason the software cannot be substituted for or take the place of point-of-operation protection.

Ensure that appropriate safeties and mechanical/electrical interlocks related to point-of-operation protection have been installed and are operational before placing the equipment into service. All interlocks and safeties related to point-of-operation protection must be coordinated with the related automation equipment and software programming.

NOTE: Coordination of safeties and mechanical/electrical interlocks for point-of-operation protection is outside the scope of the Function Block Library, System User Guide, or other implementation referenced in this documentation.

Start-up and Test

Before using electrical control and automation equipment for regular operation after installation, the system should be given a start-up test by qualified personnel to verify correct operation of the equipment. It is important that arrangements for such a check are made and that enough time is allowed to perform complete and satisfactory testing.

▲ WARNING

EQUIPMENT OPERATION HAZARD

- Verify that all installation and set up procedures have been completed.
- Before operational tests are performed, remove all blocks or other temporary holding means used for shipment from all component devices.
- Remove tools, meters, and debris from equipment.

Failure to follow these instructions can result in death, serious injury, or equipment damage.

Follow all start-up tests recommended in the equipment documentation. Store all equipment documentation for future references.

Software testing must be done in both simulated and real environments.

Verify that the completed system is free from all short circuits and temporary grounds that are not installed according to local regulations (according to the National Electrical Code in the U.S.A, for instance). If high-potential voltage testing is necessary, follow recommendations in equipment documentation to prevent accidental equipment damage.

Before energizing equipment:

- Remove tools, meters, and debris from equipment.
- Close the equipment enclosure door.

- Remove all temporary grounds from incoming power lines.
- Perform all start-up tests recommended by the manufacturer.

Operation and Adjustments

The following precautions are from the NEMA Standards Publication ICS 7.1-1995 (English version prevails):

- Regardless of the care exercised in the design and manufacture of equipment or in the selection and ratings of components, there are hazards that can be encountered if such equipment is improperly operated.
- It is sometimes possible to misadjust the equipment and thus produce unsatisfactory or unsafe operation. Always use the manufacturer's instructions as a guide for functional adjustments. Personnel who have access to these adjustments should be familiar with the equipment manufacturer's instructions and the machinery used with the electrical equipment.
- Only those operational adjustments actually required by the operator should be accessible to the operator. Access to other controls should be restricted to prevent unauthorized changes in operating characteristics.

About the Book

Document Scope

This document presents a PlantStruxure feature: at source applicative time stamping.

This guide presents detailed information about applicative time stamping, including the following:

- Applicative time stamping architecture
- Design and configuration phases
- Commissioning and operation phases

Validity Note

This document is valid for EcoStruxure™ Control Expert 14.0 or later .

The technical characteristics of the devices described in the present document also appear online. To access the information online, go to the Schneider Electric home page www.se.com/www/en/download/.

The characteristics that are described in the present document should be the same as those characteristics that appear online. In line with our policy of constant improvement, we may revise content over time to improve clarity and accuracy. If you see a difference between the document and online information, use the online information as your reference.

Related Documents

| Title of documentation | Reference number |
|--|--|
| Modicon X80, BMXERT1604T Time Stamp Module, User Guide | EIO0000001121 (English), EIO0000001122 (French), EIO0000001123 (German), EIO0000001125 (Italian), EIO0000001124 (Spanish), EIO0000001126 (Chinese) |
| Quantum EIO, Remote I/O Modules, Installation and Configuration Guide | S1A48978 (English), S1A48981 (French), S1A48982 (German), S1A48983 (Italian), S1A48984 (Spanish), S1A48985 (Chinese) |
| Quantum using EcoStruxure™ Control Expert, Hot Standby System, User Manual | 35010533 (English), 35010534 (French), 35010535 (German), 35013993 (Italian), 35010536 (Spanish), 35012188 (Chinese) |
| EcoStruxure™ Control Expert, System Bits and Words, Reference Manual | EIO0000002135 (English), EIO0000002136 (French), EIO0000002137 (German), EIO0000002138 (Italian), |

| Title of documentation | Reference number |
|--|--|
| | EIO0000002139 (Spanish), EIO0000002140 (Chinese) |
| EcoStruxure™ Control Expert, System, Block Library | 33002539 (English), 33002540 (French), 33002541 (German), 33003688 (Italian), 33002542 (Spanish), 33003689 (Chinese) |
| EcoStruxure™ Control Expert, Communication, Block Library | 33002527 (English), 33002528 (French), 33002529 (German), 33003682 (Italian), 33002530 (Spanish), 33003683 (Chinese) |
| Quantum using EcoStruxure™ Control Expert, 140 ERT 854 10 Time Stamp Module, User Manual | 33002499 (English) |
| Quantum using EcoStruxure™ Control Expert, 140 ERT 854 20 Time Stamp Module, User Manual | S1B76798 (English), S1B76799 (French), S1B76800 (German), S1B76802 (Italian), S1B76801 (Spanish), S1B76804 (Chinese) |
| Modicon TSX NTP 100 Readme (Instruction Sheet) | 31005021 (Eng) |

You can download these technical publications, the present document and other technical information from our website www.se.com/en/download/.

Introduction to Applicative Time Stamping

What's in This Part

| | |
|--------------------|----|
| Presentation | 12 |
|--------------------|----|

Introduction

This part introduces the concepts, solutions and limitations of applicative time stamping.

Presentation

What's in This Chapter

Applicative Time Stamping Concepts..... 12
 Applicative Time Stamping Limitations..... 13

Applicative Time Stamping Concepts

Definition

The applicative time stamping provides time stamped events buffers to the PLC application in order to be accessed from a 3rd party SCADA which is not interfaced via OFS/OPC DA. The user can convert the format of events read from time stamped events buffers into a user format dedicated to the 3rd party SCADA.

An event is a discrete I/O value change (transition) detected by a time stamping module. The applicative time stamping provides a consistent SOE (sequence of events), time stamped at the source.

Sources

The applicative time stamping solution is managed by the following events sources:

- BMX ERT 1604 T module inputs
- 140 ERT 854 •0 module inputs
- Discrete I/O modules inputs or outputs in a Modicon X80 Ethernet I/O drop with a BMX CRA 312 10 module

The applicative time stamping is supported in Quantum Hot Standby systems.

In a safety Quantum application, the applicative time stamping is only managed by 140 ERT 854 20 module inputs.

Process

Time stamped events are managed as follows:

- Each time stamping module records events in its local buffer.
- The PLC application consumes time stamped events from the modules local buffer and stores the data in the PLC raw records buffer.
- The PLC application converts the PLC raw records data to a user format record and stores the data.

- The supervision application consumes the user format records.

Solution Configuration

On discrete I/Os time stamped by a BMX CRA 312 10, the user can configure:

- the behavior of time stamped buffers on:
 - buffer full
 - power on
 - Stop to Run transition
- the edges transitions to time stamp (rising, falling, rising, and falling edges for each discrete I/O)

On BMX ERT 1604 T modules, the above mentioned parameters are preset and cannot be changed:

- Stop the recording on buffer full.
- Keep module buffer content on power on if the application is the same.
- Keep module buffer content on Stop to Run transition.
- Both edges transition (edge detection).

Applicative Time Stamping Limitations

Features

System limitations:

- At source time stamped events online change service is not available.
- Internal PLC variables can not be timed stamped using at source time stamping solution.
- No selection of transition edges on time stamped events in a BMX ERT 1604 T module (events are time stamped on rising and falling edges).
- In a Modicon M340 local drop, the maximum number of BMX ERT 1604 T modules depends on the local drop CPU type, refer to Compatibility and Limitations (see Modicon X80, BMXERT1604T/H Time Stamp Module, User Manual) topic for more details.
- In a Quantum application, only 25 BMX ERT 1604 T modules are supported per application.
- In an M580 application, the number of BMX ERT 1604 T modules per application is not limited.

NOTE: For M580 CPU with OS version ≤ 2.40 , the number of BMX ERT 1604 T modules per application is limited to 25.

- A Modicon X80 Ethernet RIO drop supports up to 36 expert channels. A BMX ERT 1604 T module is counted as 4 expert channels.
- Maximum of 9 x 140 ERT 854 10 modules in a S908 drop.
- Maximum of 8 x 140 ERT 854 20 modules in a S908 drop.
- Maximum of 2500 discrete I/Os per Quantum PLC.
- Maximum of 144 discrete inputs per Modicon M340 PLC (local drop).
- The CCOTF function is not supported by BMX ERT 1604 T modules.

Compatibility:

- A Hot Standby system is compatible with applicative time stamping. For more details on Hot Standby system, refer to the *Modicon Quantum Hot Standby System User Manual*.
- A Quantum Safety PLC is compatible with applicative time stamping. For more details, refer to the *Modicon Quantum, Quantum Safety PLC, Safety Reference Manual*.

Applicative Time Stamping Architecture

What's in This Part

| | |
|-----------------------------|----|
| Components..... | 16 |
| Components Versions | 20 |
| Architecture Examples | 21 |
| Performances..... | 26 |

Introduction

This part presents the list of applicative time stamping components, components versions, performances and architecture examples.

Components

What’s in This Chapter

| | |
|-------------------------------|----|
| Time Synchronization..... | 16 |
| Control Expert Software | 16 |
| BMX ERT 1604 T Module | 17 |
| BMX CRA 312 10 Module..... | 17 |
| 140 ERT 854 •0 Module..... | 18 |

Overview

This chapter presents the components involved in an applicative time stamping solution.

Time Synchronization

Time Synchronization

Time synchronization is a key point in the applicative time stamping solution. Time synchronization between the time stamping events sources (using different external source clocks) is the prerequisite to have a functional time stamping solution.

Time synchronization means:

- BMX ERT 1604 T: DCF77 or IRIG-B 004/5/6/7 external clock
- 140 ERT 854 10: DCF77 external clock
- 140 ERT 854 20: DCF77 or IRIG-B 004/5/6/7 external clock, TSX NTP 100, page 9 module
- BMX CRA 312 10: NTP server

Control Expert Software

Control Expert Role

Control Expert software is a programming, debugging and operating software for most Schneider Electric PLCs. It allows the full development of applications.

Control Expert is necessary in a time stamping solution to program the PLC system.

Quantum Hot Standby systems support the applicative time stamping solution.

Safety Quantum application only support the time stamping at the source with 140 ERT 854 20 modules.

BMX ERT 1604 T Module

BMX ERT 1604 T Role

The BMX ERT 1604 T module is a time stamping source that can be used in a local Modicon M340 drop or in a Modicon X80 drop.

The BMX ERT 1604 T is a 16 discrete input channels module able to generate time stamping events on input value changes. To time stamp its inputs, the BMX ERT 1604 T module is connected to an external GPS clock (IRIG-B 004/5/6/7 or DCF77 time code) or a DCF77 radio receiver.

NOTE: Some of the BMX ERT 1604 T module channels can also be used as simple discrete inputs or incremental counting inputs.

For more details on the BMX ERT 1604 T module, refer to the *BMX ERT 1604 T M340 ERT Module User Manual*.

The BMX ERT 1604 T inputs use positive (or sink) logic and the voltage input ranges are as follows:

- 24 Vdc
- 48 Vdc
- 60 Vdc
- 110 Vdc
- 125 Vdc

BMX CRA 312 10 Module

BMX CRA 312 10 Role

The BMX CRA 312 10 module is a communication module on a Modicon X80 Ethernet remote I/O drop.

BMX CRA 312 10 module features:

- In a Quantum Ethernet I/O solution, these modules exchange data with the Quantum PLC head module: 140 CRP 312 00.

- In addition to its communication function, a BMX CRA 312 10 module can time stamp any discrete I/O on discrete modules located in the drop. BMX CRA 312 10 module evaluates periodically discrete input and output values and if a change is detected it is time stamped and stored in the module internal local event buffer. This buffer makes the information available for the final client and its behavior needs to be defined in Control Expert software.

For time stamping application, the BMX CRA 312 10 module requires a direct link to an accurate NTP server time source, page 16.

Discrete Inputs and Outputs

The BMX CRA 312 10 module is able to time stamp any discrete module located in the drop.

Compatible Modicon X80 discrete modules:

| Modules Reference | | | | |
|-------------------|---------------|---------------|---------------|--------------|
| BMX DAI 0805 | BMX DDI 1602 | BMX DDM 16022 | BMX DDO 1602 | BMX DRA 0804 |
| BMX DAI 0814 | BMX DDI 1603 | BMX DDM 16025 | BMX DDO 1612 | BMX DRA 0805 |
| BMX DAI 1602 | BMX DDI 1604 | BMX DDM 3202K | BMX DDO 3202K | BMX DRA 0815 |
| BMX DAI 1603 | BMX DDI 3202K | | BMX DDO 6402K | BMX DRA 1605 |
| BMX DAI 1604 | BMX DDI 6402K | | | BMX DRC 0805 |
| BMX DAI 1614 | | | | |
| BMX DAI 1615 | | | | |
| BMX DAO 1605 | | | | |
| BMX DAO 1615 | | | | |

140 ERT 854 •0 Module

140 ERT 854 •0 Role

The 140 ERT 854 •0 modules are intelligent 32 point discrete input modules for Quantum able to generate time stamping events on input changes. To time stamp their inputs, the 140 ERT 854 •0 modules are connected to an external clock (DCF77 or IRIG-B time code). The 140 ERT 854 20 module can be connected to a TSX NTP 100, page 9 external module that receives time code from NTP servers and transforms it to a time code on RS485 link.

For more details on the 140 ERT 854 •0 modules, refer to the *Quantum using EcoStruxure™ Control Expert, 140 ERT 854 10 Time Stamp Module, User Manual* and *Quantum using EcoStruxure™ Control Expert, 140 ERT 854 20 Time Stamp Module, User Manual*.

Time stamping with 140 ERT 854 •0 modules is not described in this document.

Components Versions

What's in This Chapter

Components Version20

Components Version

General

The following table shows the applicative time stamping component required versions:

| Component | Version |
|---|--------------|
| Unity Pro Software NOTE: Unity Pro is the former name of Control Expert for version 13.1 or earlier. | 7.0 or later |
| BMX ERT 1604 T | 1.0 or later |
| BMX CRA 312 10 | 1.0 or later |
| 140 ERT 854 20 | 1.0 or later |

Architecture Examples

What's in This Chapter

| | |
|---|----|
| Time Stamping Typical Architecture..... | 21 |
|---|----|

Overview

This chapter provides typical time stamping architectures.

Time Stamping Typical Architecture

Overview

Time stamping can be applied to Quantum or Modicon M340 PLC architectures.

The following table presents the devices combination required in an applicative time stamping architecture:

| PLC (local drop) | | | Ethernet Remote I/O Drop | | |
|------------------|----------------------|--------------------------------|---|---|--------------------------------|
| Family | Time Stamping Source | Time Synchronization | Family | Time Stamping Source | Time Synchronization |
| Modicon M340 | BMX ERT 1604 T | DCF77 or IRIG-B 004/5/6/7 | N.A. | N.A. | N.A. |
| Quantum (1.) | 140 ERT 854 •0 | DCF77 or IRIG-B 004/5/6/7 (4.) | Quantum (2.) | 140 ERT 854 •0 | DCF77 or IRIG-B 004/5/6/7 (4.) |
| | | | Modicon X80 (Modicon M340) (2.) | BMX CRA 312 10 | NTP Server (3.) |
| | | | | BMX ERT 1604 T | DCF77 or IRIG-B 004/5/6/7 |
| | | | Mix of both possible sources: <ul style="list-style-type: none"> • BMX CRA 312 10 • BMX ERT 1604 T | Each source has its time reference: <ul style="list-style-type: none"> • NTP Server (3.) for BMX CRA 312 10 • DCF77 or IRIG-B 004/5/6/7 for BMX ERT 1604 T | |

N.A. Not Applicable

1. Quantum Hot Standby configurations are compatible with applicative time stamping.
2. A time stamping architecture may contain several Ethernet remote I/O drops with time stamping sources.
3. A single NTP server can provide time reference to many BMX CRA 312 10 modules.
4. A TSX NTP 100 module can provide an RS485 time source (based on an NTP server) to the 140 ERT 854 20 module. The 140 ERT 854 10 module only accepts DCF77 time synchronization.

The following topics present graphically some of the devices combination allowed in an applicative time stamping architecture (it is not an exhaustive list, it represents typical application examples).

Quantum PLC (Local Drop) With a 140 ERT 854 •0 Module

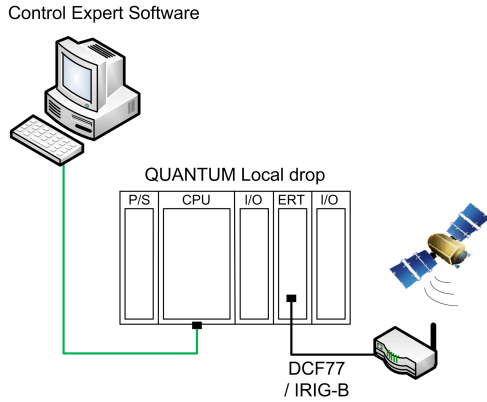

In this example, the Quantum local drop contains a 140 ERT 854 •0 module.
The 140 ERT 854 •0 module is the time stamped events source.
The time source is a GPS module connected to the 140 ERT 854 •0.

Quantum PLC with a Quantum Ethernet I/O Drop Including a 140 ERT 854 •0 Module

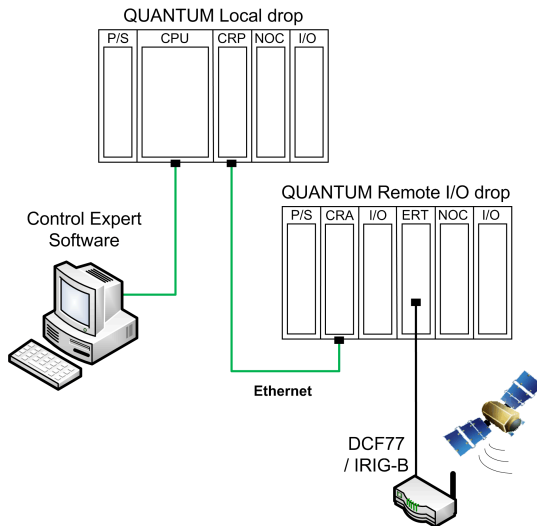

In this example, the Quantum Ethernet I/O architecture contains a Quantum Ethernet remote I/O drop.

The 140 ERT 854 •0 module is the time stamped events source.

The time source is a GPS module connected to the 140 ERT 854 •0.

Quantum PLC with a Modicon X80 Drop

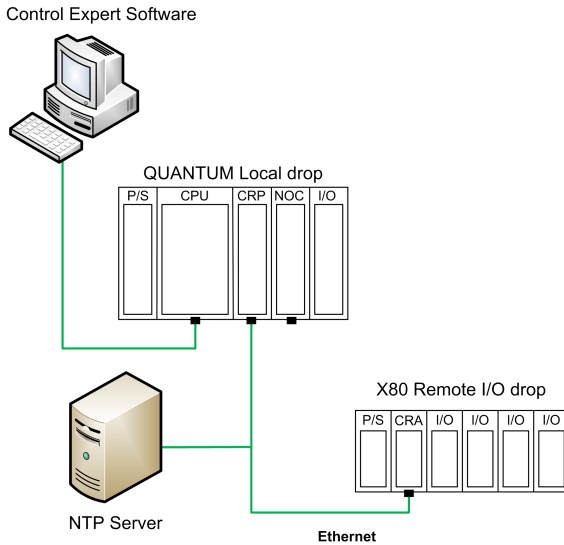

In this example, the Quantum Ethernet I/O architecture contains a Modicon X80 (Modicon M340) Ethernet I/O drop.

On the remote I/O drop, the BMX CRA 312 10 module is the time stamped events source. It time stamps I/O transitions on the discrete I/O modules in the remote I/O drop.

The time source is an NTP server connected to the Ethernet remote I/O bus.

Quantum PLC with a Modicon X80 Drop Including BMX ERT 1604 T and BMX CRA 312 10 Modules with a GPS Time Reference

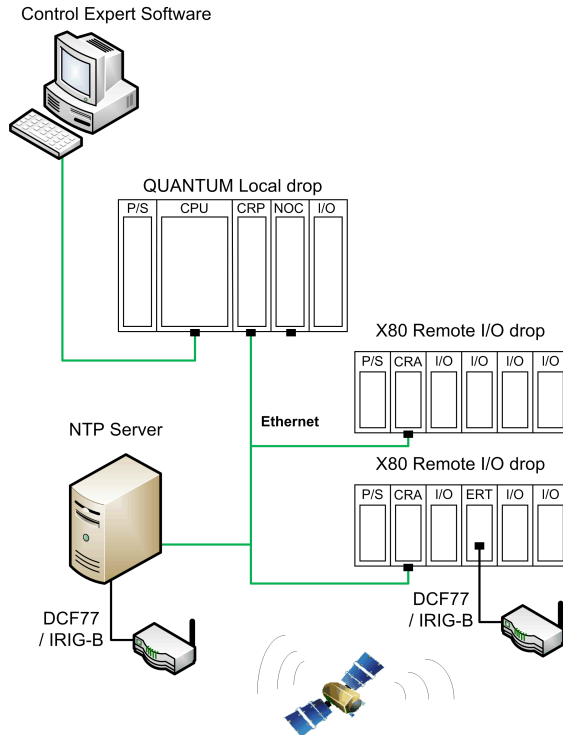

In this example, the Quantum Ethernet I/O architecture contains 2 Modicon X80 (Modicon M340) Ethernet I/O drops.

On each remote I/O drop, either BMX CRA 312 10 or BMX ERT 1604 T modules are the time stamped events sources.

The time source is an NTP server connected to a GPS source for the BMX CRA 312 10 modules and a dedicated GPS source for the BMX ERT 1604 T module.

Performances

What's in This Chapter

Components and System26

Overview

This chapter describes the applicative time stamping system performances and limitations.

Components and System

Components Performances

The following table sums up components performance in a time stamping solution:

| Topic | Device | Value |
|--|----------------|--|
| Time stamp resolution (between 2 identical source modules) | BMX ERT 1604 T | 2 < time stamp resolution < 4 ms (with the same time source) |
| | BMX CRA 312 10 | 10 ms |
| | 140 ERT 854 20 | 1.5 ms |
| Time stamp resolution (in the same source module) | BMX ERT 1604 T | 1 ms |
| | BMX CRA 312 10 | 1 cycle time (< 10 ms) |
| | 140 ERT 854 •0 | 1 ms |
| Maximum number of I/O and available memory ^(1.) | BMX ERT 1604 T | 16 discrete inputs on the module |
| | | 255 events in internal buffer |
| | BMX CRA 312 10 | 256 discrete I/O configured |
| | | 4000 events in internal buffer |
| | 140 ERT 854 •0 | 32 discrete inputs on the module |
| 4096 events in internal buffer | | |
| 1. The maximum value depends on the global system performance, it is not an absolute value and must be balanced. | | |

System Limitations

The following table sums up system limitations in a time stamping solution:

| Topic | Description | Value |
|---|--|-------------------------------------|
| Maximum amount of devices in an Ethernet remote I/O drop | BMX CRA 312 10 | 1 per drop |
| | BMX ERT 1604 T | 9 per drop ^(1.) |
| | 140 ERT 854 •0 | No limitation ^(2.) |
| Maximum amount of devices in the system | BMX CRA 312 10 | 31 in the system |
| | BMX ERT 1604 T | 25 in the system |
| Maximum amount of sources of events polled | Maximum discrete I/Os per PLC (Modicon M340 local drop or Quantum PLC) | 2500 |
| Maximum amount of discrete inputs (and outputs) monitored by the PLC for all the time stamping modules | For all the BMX ERT 1604 T | 400 discrete inputs ^(3.) |
| | For all the BMX CRA 312 10 | 2048 discrete I/O ^(3.) |
| Maximum number of events per reading request | For a BMX ERT 1604 T EFB request | 20 |
| Minimum timeout setting between reading requests | Between BMX ERT 1604 T EFB requests | 5 ms |
| <p>1. A BMX ERT 1604 T module contains 4 expert channels. A Modicon X80 drop supports a maximum of 36 expert channels, so it supports a maximum of 9 x BMX ERT 1604 T modules if there is no BMX EHC 0•00 counting module in the drop.</p> <p>2. In a Quantum S908 remote I/O architecture, 9 x 140 ERT 854 10 and 8 x 140 ERT 854 20 modules per drop.</p> <p>3. The maximum value depends on the global system performance, it is not an absolute value and must be balanced.</p> | | |

Design and Configuration Phases for Modicon M340 Modules

What's in This Part

| | |
|---|----|
| Applicative Time Stamping Service Activation | 29 |
| Selecting the Appropriate Time Stamping Module..... | 32 |
| Selecting and Setting Time Synchronization..... | 34 |
| Selecting and Configuring the Variables to Time Stamp | 39 |
| User Application | 45 |

Introduction

This part presents the phases required to design and configure the applicative time stamping from service activation to diagnostic in a Modicon M340 local drop or Modicon X80 Ethernet remote drop in a Quantum Ethernet I/O architecture.

NOTE: Time stamping with 140 ERT 854 *0 modules is described in the *Quantum using EcoStruxure™ Control Expert, 140 ERT 854 10 Time Stamp Module, User Manual* and *Quantum using EcoStruxure™ Control Expert, 140 ERT 854 20 Time Stamp Module, User Manual*.

Applicative Time Stamping Service Activation

What's in This Chapter

Applicative Time Stamping Service Configuration 29
 Control Expert Project Settings 30

Overview

This chapter describes the actions to be performed in order to activate the applicative time stamping in Control Expert software.

Applicative Time Stamping Service Configuration

Configuration Sequence

The following table presents the sequence to follow in order to configure the applicative time stamping in Control Expert:

| Step | Action |
|------|--|
| 1 | Create an application in Control Expert with time stamping modules. Select the appropriate time stamping modules, page 32. |
| 2 | Set Control Expert project settings, page 30. |
| 3 | Set the time stamping modules time sources parameters, page 34. |
| 4 | Select the events, page 39 to time stamp. |
| 5 | Set the BMX CRA 312 10 module buffer parameters, page 42 (BMX ERT 1604 T module buffer parameters, page 39 are preset). Set the time stamped events parameters. |
| 6 | Define and set the EFBs, page 45 dedicated to time stamping. |

Control Expert Project Settings

At a Glance

In Control Expert software, to allow applicative time stamping, adjust the **Project Settings** by clicking **Tools > Project Settings > General**.

NOTE: Those settings only apply to BMX CRA 312 10 and BMX ERT 1604 T modules. They do not apply to 140 ERT 854 *0 modules.

Time Stamping Parameters

Click **General > Time** to reach time stamping parameter:

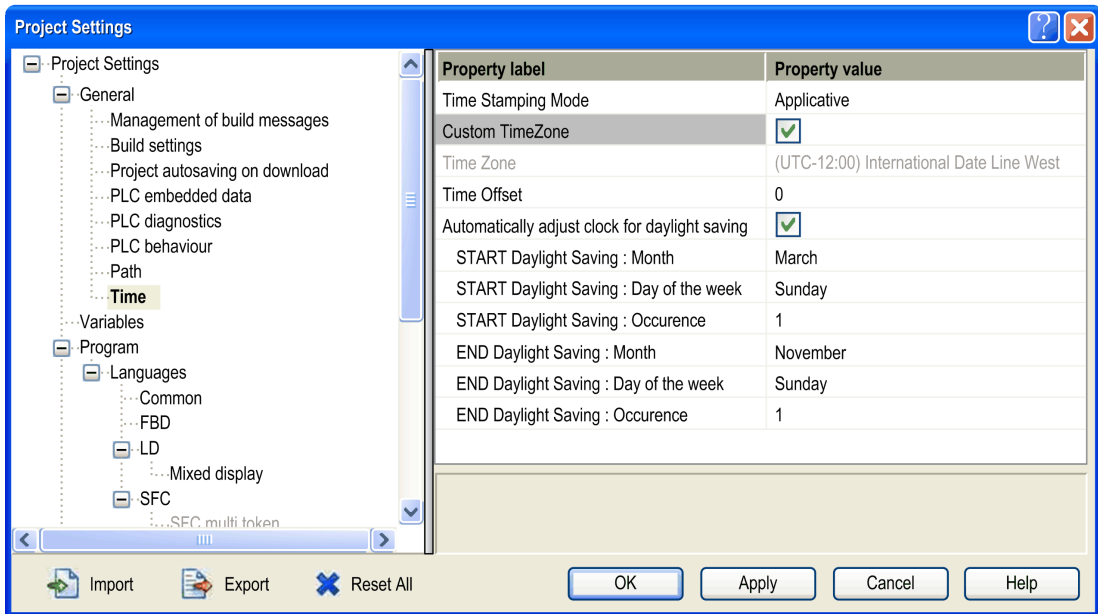

In **Time** field, set the time stamping mode and time zone:

| Subfield | Value for Applicative Time Stamping | Description |
|---------------------------|-------------------------------------|--|
| Time Stamping Mode | Applicative | Select Applicative to enable applicative time stamping. |
| Custom TimeZone | Enabled or Disabled | Enable or disable a custom time zone, user selects the values. <ul style="list-style-type: none"> If disabled, Time Zone can be chosen in the following drop-down box. |

| Subfield | Value for Applicative Time Stamping | Description |
|--|-------------------------------------|--|
| | | <ul style="list-style-type: none"> If enabled, Time Offset and Automatically adjust clock for daylight saving settings can be adjusted. |
| Time Zone | (1.) | Can be selected if Custom TimeZone is disabled only. Select one of the most common time zone. |
| Time Offset | (1.) | Can be selected if Custom TimeZone is enabled only. The selected value (- 1439 ... + 1439 minutes) is added to current local time. |
| Automatically adjust clock for daylight saving | (1.) | Can be selected if Custom TimeZone is enabled only (2.). When enabled, START and END daylight saving parameters can be adjusted in the following subfields to have the clock adjusted by +1 hour when daylight saving starts, then be adjusted by -1 hour when daylight saving ends. NOTE: DST START and END hours are preset if they are not displayed. |
| 1. No specific value required for applicative time stamping, depends on Custom TimeZone subfield value. 2. BMX ERT 1604 T modules do not use the automatic daylight saving adjustment setting. | | |

Time stamped events are marked in UTC values and the time zone settings allow to convert GPS local time to UTC values in BMX ERT 1604 T.

NOTE: When the source of time stamped events is a BMX CRA 312 10 module, the time zone settings have no influence on time stamped events (the module uses UTC time from the NTP server) but the time zone settings are used for diagnostic purpose (local time is needed).

NOTE: The daylight saving time settings are not applicable to the BMX ERT 1604 T module because this module gets the daylight saving time switching information from the external clock (DCF77 or IRIG-B 004/5/6/7 time code).

Variables Settings

Dynamic arrays must be enabled in the application to allow applicative time stamping function.

Click **General > Variables** and check the **Allow dynamic arrays (ANY_ARRAY_XXX)** check box.

Selecting the Appropriate Time Stamping Module

What’s in This Chapter

Time Resolution.....32

Overview

This chapter describes the modules available to provide the desired time stamp resolution.

Time Resolution

Overview

Time resolution is a key point in selecting the time stamped events sources.

Time and time stamp resolution are to be understood as follows:

- Internal module time resolution: absolute time resolution depending on the module internal clock (and I/O management for BMX CRA 312 10 module).
- Time stamp resolution between 2 events in the same module: depends on the module internal I/O polling rate or cycle.
- Time stamp resolution between 2 events on different source modules of the same family (BMX ERT 1604 T or BMX CRA 312 10): time resolution between 2 source modules depends on the time source (external clock) tolerance, each module internal time resolution (and network transmission delay for modules synchronized through NTP).
- Time stamp resolution between 2 events on different source modules of a different family (BMX ERT 1604 T and BMX CRA 312 10): same constraints as with 2 source modules of the same family, except that the time stamp resolution will be the one of the less accurate module.

Time and Time Stamp Resolution

| Value | System Events Source Module(s) | Value | Comment |
|--------------------------|--------------------------------|-------|---------------------------|
| Internal time resolution | BMX ERT 1604 T | 1 ms | Internal clock resolution |
| | BMX CRA 312 10 | | Internal clock resolution |

| Value | System Events Source Module(s) | Value | Comment |
|--|--|---|---|
| Time stamp resolution between 2 events in the same module | BMX ERT 1604 T | 1 ms | |
| | BMX CRA 312 10 | 1...3 ms (module scan time) | Time stamp resolution depends on the module cycle time |
| Time stamp resolution between 2 events on different source modules | n x BMX ERT 1604 T ^(1.) | <ul style="list-style-type: none"> • 2 ms with IRIG-B 004/5/6/7 time code (GPS) • 4 ms with DCF77 time code | NOTE: Time stamp resolution is given provided that each BMX ERT 1604 T module is supplied with the same time source. |
| | n x BMX CRA 312 10 ^(1.) | 10 ms | |
| | n x BMX ERT 1604 T + n x BMX CRA 312 10 ^(1.) | 10 ms | NOTE: Highest time stamp resolution becomes the system time stamp resolution. |
| 1. n = many modules, maximum value depends on system architecture | | | |

Selecting and Setting Time Synchronization

What's in This Chapter

| | |
|--------------------------------------|----|
| Selecting the Time Source | 34 |
| Control Expert Project Setting | 36 |
| BMX ERT 1604 T Clock Settings..... | 36 |
| BMX CRA 312 10 Clock Settings..... | 37 |

Overview

This chapter describes the available time sources, the time synchronization principles and corresponding software settings.

Selecting the Time Source

Overview

To allow a consistent sequence of events, a unique time reference is needed to synchronize the local time on each time stamping module of the system.

This time reference can be an NTP server, or GPS receiver modules providing a time reference to an NTP server and directly to the BMX ERT 1604 T modules.

Time Reference Selection

The following table shows the recommended time reference based on the system architecture:

| Time Stamping Module in the System | Recommended Time Reference | Description |
|---|---|--|
| The system contains only BMX CRA 312 10 time stamping modules | NTP server | <p>An NTP server is connected on the control Ethernet network (if such a network is available on the PLC) or on the Ethernet remote I/O network, page 24.</p> <p>With a unique NTP server available:</p> <ul style="list-style-type: none"> • the PLC synchronizes its time on the NTP server. • the BMX CRA 312 10 modules synchronize their clock on the same NTP server. |
| The system contains at least 1 x BMX ERT 1604 T module | IRIG-B 004/5/6/7 or DCF77 time code from a GPS signal | <p>The GPS provides the time reference to the time sources, page 25.</p> <p>In this case:</p> <ul style="list-style-type: none"> • the PLC synchronizes its time on an NTP server synchronized on a GPS receiver. • the BMX CRA 312 10 modules synchronize their clock on the same NTP server as the PLC. • the BMX ERT 1604 T modules synchronize their clock on a GPS receiver. |

Time Sources for Modules

The following table defines the time sources recommended for each time stamping event source module:

| Module | Time Source |
|----------------|--|
| BMX ERT 1604 T | GPS time source (IRIG-B 004/5/6/7 or DCF77 time code), page 24 This solution provides the most accurate time source. |
| | Radio receiver time source (DCF77 time code) based on a radio transmitter located in germany near Frankfurt with an action range mainly limited to Europe. NOTE: For more details on clock sources connection on the BMX ERT 1604 T module, refer to chapter <i>Physical Implementation</i> (see Modicon X80, BMXERT1604T/H Time Stamp Module, User Manual). |
| BMX CRA 312 10 | NTP server, page 25 An NTP server must be available on the Ethernet network accessible from the BMX CRA 312 10 module and set in Control Expert. NOTE: For more details on NTP server configuration in Control Expert, refer to chapter <i>NTP Configuration in Control Expert</i> (see Quantum EIO, Remote I/O Modules, Installation and Configuration Guide). |

Control Expert Project Setting

Time Zone

Adjust **Project Settings** in Control Expert, page 30 and set time zone parameters.

BMX ERT 1604 T Clock Settings

BMX ERT 1604 T Clock

To set the clock type, select the module **Configuration** tab by double-clicking the BMX ERT 1604 T module in the drop.

BMX ERT 1604 T module can be in a local drop or in a Modicon X80 drop as shown in the following figure:

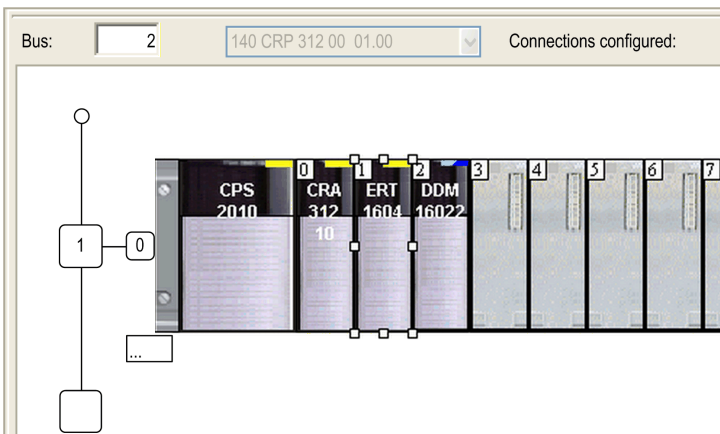

Select the clock type by setting the **Clock SYNC source** value:

| | Label | Symbol | Value | Unit |
|---|-------------------------|--------|-----------------------|--------|
| 0 | Supply Monitoring | | Enable | |
| 1 | Rated Voltage | | 24 Vdc | |
| 2 | Clock SYNC source | | IRIG-B/External Clock | |
| 3 | Debounce filter type | | Steady state | |
| 4 | Dechatter filter | | Disable | |
| 5 | Channel 0 used | | Enable | |
| 6 | Channel 0 edge | | Both edges | |
| 7 | Channel 0 debounce time | | 1 | ms |
| 8 | Channel 0 chatter count | | 255 | |
| 9 | Channel 0 chatter time | | 255 | 100 ms |

The allowed clock sources are:

- **IRIG-B/External Clock**
- **DCF77/External Clock**
- **Free Running/Internal Clock** (do not use this mode as it does not offer enough accuracy)

NOTE: In **Free Running/Internal Clock** mode, the BMX ERT 1604 T module uses its internal clock. When initialized, the initial time is: 1970-01-01 00:00:00:000 as defined in IEC61850 but the time information provided is not reliable.

BMX CRA 312 10 Clock Settings

BMX CRA 312 10 Clock

The BMX CRA 312 10 module clock is provided by an Ethernet NTP server. The server access is configured on the Quantum Ethernet I/O head module: 140 CRP 312 00.

NTP Server Settings

To access the NTP server parameters, double-click the 140 CRP 312 00 module in the local drop:

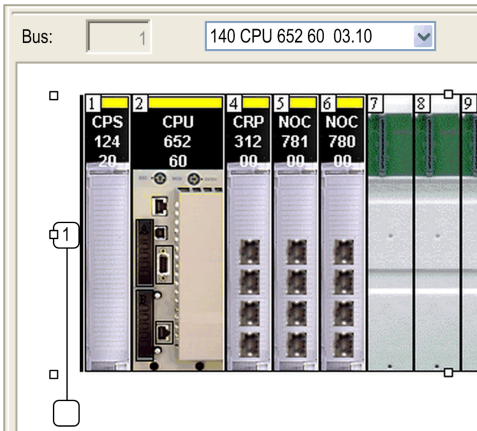

Select the **NTP** tab and set the parameters:

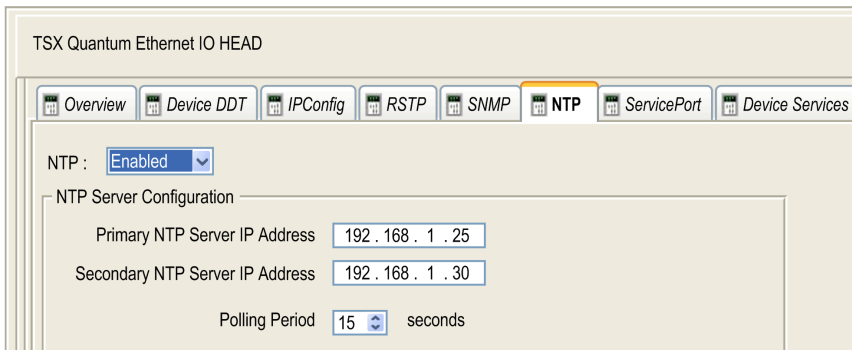

NTP parameters values:

- **NTP:** Enabled
- **Primary NTP Server IP address:** IP address
- **Secondary NTP Server IP address:** IP address
- **Polling Period:** 1...120 seconds.
 - Recommended value: < 20 seconds

Selecting and Configuring the Variables to Time Stamp

What's in This Chapter

| | |
|------------------------------|----|
| Variables Usage | 39 |
| BMX ERT 1604 T Settings..... | 39 |
| BMX CRA 312 10 Settings..... | 42 |

Overview

This chapter presents the impact of time stamping on system performance and how to configure the time stamping variables.

Variables Usage

System Performance

Time stamping events usage has to be restricted to real needs. Each time stamped event adds additional communication to the system and thus limits the global system bandwidth.

System performance is therefore limited by intensive time stamping variables usage. Only select the variables that really need to be mapped on time stamped events.

System Limitations

System limitations, page 27 represent the maximum physical limits allowed in the system.

BMX ERT 1604 T Settings

Buffer Settings

BMX ERT 1604 T buffer behavior settings can not be adjusted and they are set as follows:

- **on buffer full:** The BMX ERT 1604 T module stops the recording when the events buffer is full (stop the recording).
- **on power on:** New events are added to the existing events buffer if the application is the same.

NOTE: If the application is not the same, on power on the event buffer is cleared.

- on **STOP to RUN:** New events are added to the existing events buffer.

Time Stamping Variables

To select the variables to time stamp, double-click the BMX ERT 1604 T module in the drop.

BMX ERT 1604 T configuration screen:

DIG 16I 24/125 VDC TSTAMP

BMX ERT 1604

- Channel 0 - Time Stamping
- Channel 4 - Time Stamping
- Channel 8 - Counter
- Channel 12 - Discrete input

Configuration

| | Label | Symbol | Value | Unit |
|----|-------------------------|--------|--------------|--------|
| 0 | Debounce filter type | | Steady state | |
| 1 | Dechatter filter | | Disable | |
| 2 | Channel 4 used | | Enable | |
| 3 | Channel 4 edge | | Both edges | |
| 4 | Channel 4 debounce time | | 1 | ms |
| 5 | Channel 4 chatter count | | 255 | |
| 6 | Channel 4 chatter time | | 255 | 100 ms |
| 7 | Channel 5 used | | Enable | |
| 8 | Channel 5 edge | | Both edges | |
| 9 | Channel 5 debounce time | | 1 | ms |
| 10 | Channel 5 chatter count | | 255 | |
| 11 | Channel 5 chatter time | | 255 | 100 ms |
| 12 | Channel 6 used | | Enable | |
| 13 | Channel 6 edge | | Both edges | |
| 14 | Channel 6 debounce time | | 1 | ms |
| 15 | Channel 6 chatter count | | 255 | |
| 16 | Channel 6 chatter time | | 255 | 100 ms |
| 17 | Channel 7 used | | Enable | |
| 18 | Channel 7 edge | | Both edges | |
| 19 | Channel 7 debounce time | | 1 | ms |
| 20 | Channel 7 chatter count | | 255 | |
| 21 | Channel 7 chatter time | | 255 | 100 ms |

Function: Time Stamping

Task: MAST

PLC bus 0.3 : BMX E...

The 16 discrete inputs are logically grouped in 4 channels (4 inputs per channel group):

| | |
|-------------|--|
| Channel 0: | Time stamping function is mandatory for this channel. |
| Channel 4: | Time stamping function is user defined in the Function drop-down list box for this channel. |
| Channel 8: | Time stamping function is user defined in the Function drop-down list box for this channel. |
| Channel 12: | Time stamping function is user defined in the Function drop-down list box for this channel. |

Each channel group needs the following parameters to be set:

- **Debounce filter type**
- **Dechatter filter**

For each of the 16 discrete channel, set:

- **Channel x used** (Channel use is enabled or disabled)
- **Channel x debounce time**

NOTE: For time stamping function channel edge event detection is set on **Both edges** for each BMX ERT 1604 T discrete input and can not be modified.

NOTE: More details on BMX ERT 1604 T variables settings are provided in the *BMX ERT 1604 T M340 ERT Module User Manual*. The variables are automatically created in the **Data Editor** with an ID associated.

Variables Mapping

For a BMX ERT 1604 T module, 2 cases are considered:

- The module is located in the PLC local rack: mapping is the topological address of the BMX ERT 1604 T input time stamped.
- The module is located in a Modicon X80 drop: mapping is provided by device DDT. The I/O time stamped module location is used (for example \2.1\0.1 means: bus 2 (RIO), drop 1, rack 0, slot 1).

An alias can also be associated with a time stamped variable in device DDT.

BMX CRA 312 10 Settings

Buffer Settings

BMX CRA 312 10 buffer parameters are set on the Modicon X80 drop. Double-click the **EIO Modicon X80 drop** in the remote drop and click the **Time Stamping** tab:

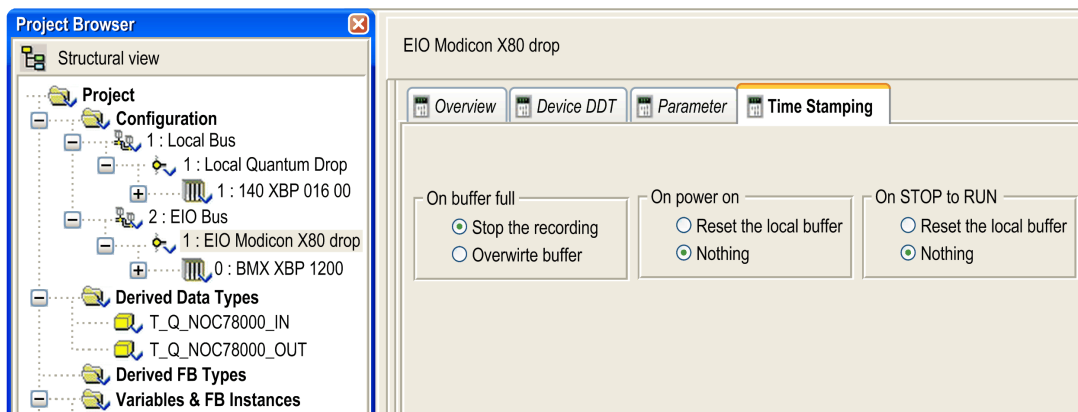

The BMX CRA 312 10 **Time Stamping** settings are as follows:

| Parameter | Value | Comment |
|----------------|--|--|
| On buffer full | Stop the recording (Default value) | Stop the recording when the events buffer is full. |
| | Overwrite buffer | The oldest events are overwritten when new events occur and the events buffer is full. |
| On power on | Reset the local buffer | The events buffer is cleared. |
| | Nothing (Default value) | New events are added to the existing events buffer if the application is the same. If the time stamping application is different, the buffer is cleared. |
| On STOP to RUN | Reset the local buffer | The events buffer is cleared. |
| | Nothing (Default value) | New events are added to the existing events buffer if the application is the same. If the time stamping application is different, the buffer is cleared. |

Time Stamping Variables

Each input and output of discrete modules, page 18 located on a Modicon X80 drop with a BMX CRA 312 10 can be time stamped.

To select a discrete module for time stamping, proceed as follows:

1. double-click the discrete module in the remote drop
2. select the **Device DDT** tab (the implicit device DDT name attributed by default to the device is mentioned in this tab)
3. click **Goto details** command button, the **Data Editor** window opens

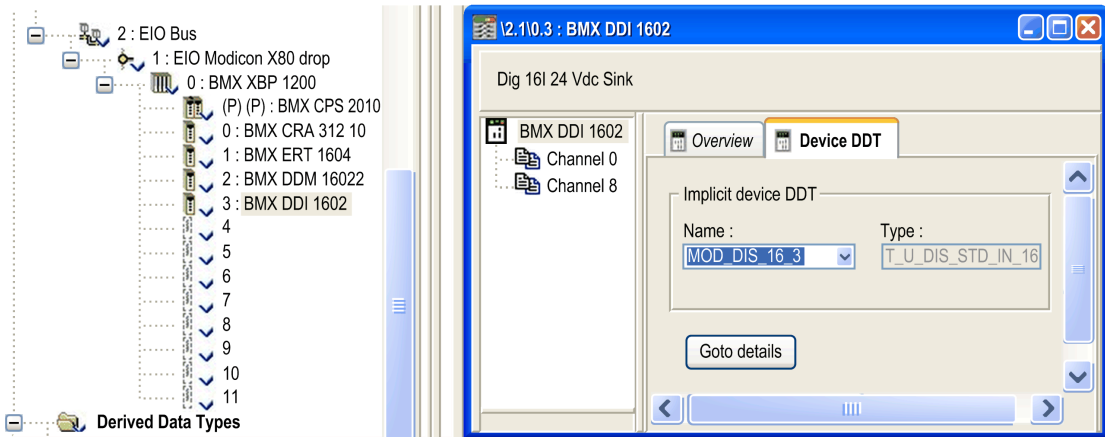

To set a channel time stamping parameter for the discrete module chosen, proceed as follows:

1. in the **Data Editor**, click the **+** beside the implicit device DDT name that corresponds to the discrete module you want to set in order to display the module elements
2. click the **+** beside **DIS_CH_IN** or **DIS_CH_OUT** elements to display each channel parameters.
3. click the **+** beside the channel to be set
4. in the **VALUE** parameter line, double-click in the **Time stamping** cell to set the event detection edge. Selecting the edge enables the channel for time stamping.

The screenshot shows the 'Data Editor' window with the 'Variables' tab selected. A filter is applied with the name '*'. The table below lists the variables and their configurations.

| Name | Type | Addr... | Value | Comment | Time stamp... | Source | TS ID |
|--------------|-------------------------|---------|-------|----------------------|---------------|--------|-------|
| DROP_1 | T_M_DROP_EXT_IN | | | | | | |
| DROP_2 | T_U_DROP_STD_IN | | | | | | |
| MOD_COM_1 | T_U_CRP_STD_IN | | | | | | |
| MOD_DIS_16_1 | T_M_DIS_ERT | | | | | | |
| MOD_DIS_16_2 | T_U_DIS_STD_IN_8_O... | | | | | | |
| MOD_DIS_16_3 | T_U_DIS_STD_IN_16 | | | | | | |
| MOD_HEALTH | BOOL | | | Module health | | | |
| MOD_FLT | BYTE | | | Module faults | | | |
| DIS_CH_IN | ARRAY[0...15] OF T_U... | | | | | | |
| DIS_CH_IN[0] | T_U_DIS_STD_CH_IN | | | | | | |
| DIS_CH_IN[1] | T_U_DIS_STD_CH_IN | | | | | | |
| CH_HEALTH | BOOL | | | Channel health | | | |
| VALUE | EBOOL | | | Discrete input value | Rising Edge | CRA | 276 |
| DIS_CH_IN[2] | T_U_DIS_STD_CH_IN | | | | | | |
| DIS_CH_IN[3] | T_U_DIS_STD_CH_IN | | | | | | |

Variables Mapping

As the module is located in a Modicon X80 drop, mapping is provided by device DDT. The I/O time stamped module location is used (for example \2.1\0.1 means: bus 2 (RIO), drop 1, rack 0, slot 1).

An alias can also be associated with a time stamped variable in device DDT.

User Application

What's in This Chapter

| | |
|--|----|
| GET_TS_EVT_M application examples | 45 |
| GET_TS_EVT_Q application examples | 47 |
| Applicative Time Stamping Functions Representation | 50 |

Overview

This chapter presents how to use applicative time stamping in Control Expert software with dedicated functions.

GET_TS_EVT_M application examples

Presentation

GET_TS_EVT_M is used to get the time stamped data in a BMX ERT 1604 T module configured in a Modicon M340 or in a Modicon M580 PLC. The BMX ERT 1604 T module can be configured in a local rack or in a drop.

The two following examples get the time stamped data in a BMX ERT 1604 T module configured in a local rack, if your module is configured in a drop use the ADDMX (see EcoStruxure™ Control Expert, Communication, Block Library) function (for instance if the BMX ERT 1604 T module is in the slot 4 of drop which ethernet IP address is 192.168.10.3 the ADDMX input will be '0.0.3{192.168.10.3}\0.4.0') instead of ADDM (see EcoStruxure™ Control Expert, Communication, Block Library) function.

GET_TS_EVT_M Simple Implementation Example

Example of implementation that reads the events in BMX ERT 1604 T buffer as long as ENABLE is true:

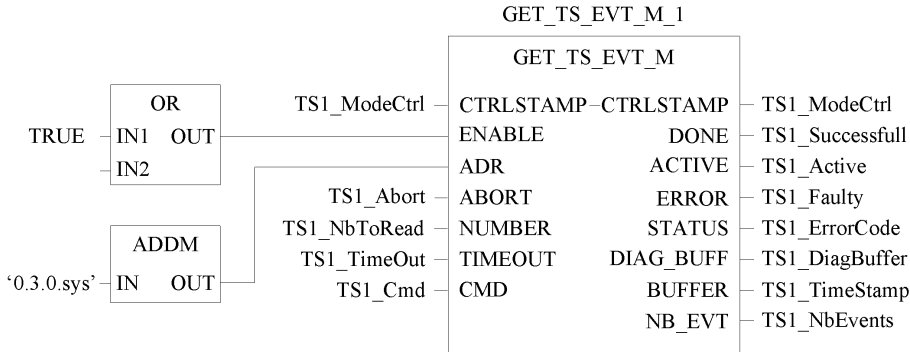

In this example the function block addresses a BMX ERT 1604 T module in the local drop. The ADDM `IN` parameter value (`'0.3.0.sys'`) means the following:

- 0: the module is in local rack number 0
- 3: the module is in slot number 3
- 0: communication port number, always set to 0 in a BMX ERT 1604 T module
- sys: keyword used to stipulate the module server system (not necessary)

GET_TS_EVT_M Specific Implementation Example

Example of implementation that reads the events in BMX ERT 1604 T buffer according to buffer filling level:

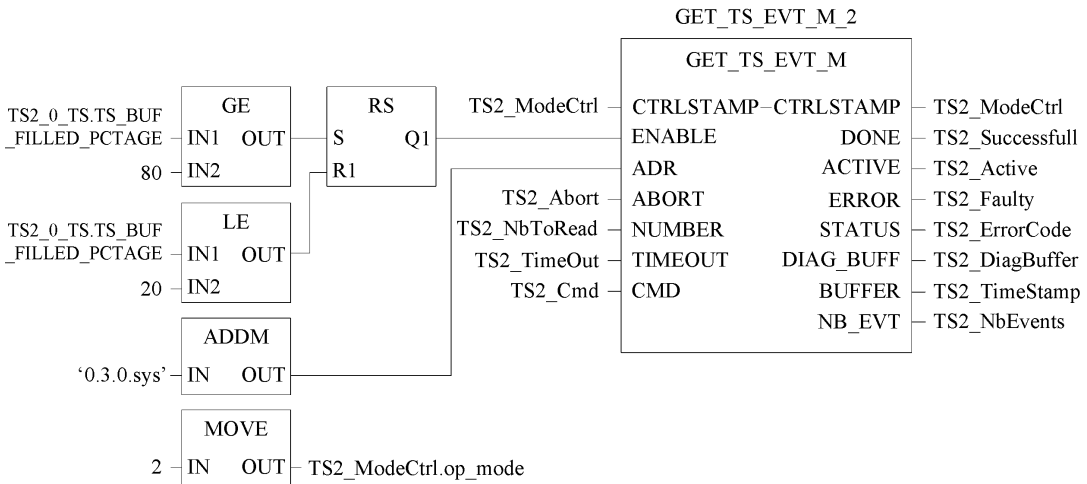

In this example the function block addresses a BMX ERT 1604 T module in the local drop with the same target address as for `GET_TS_EVT_M_1` instance. Here we focus our explanation on the condition by which the function block is enabled:

- Events are read in the BMX ERT 1604 T module buffer when the buffer filling level is greater than or equal to 80% (GE function block)
- The function block stops reading events in the BMX ERT 1604 T module buffer when the buffer filling level is lower than or equal to 20% (LE function block)

GET_TS_EVT_Q application examples

Presentation

In a Quantum Ethernet I/O system, the `GET_TS_EVT_Q` function is used to get the time stamped data in a Modicon X80 remote drop.

The two following examples get the time stamped data in a:

- BMX CRA 312 10 module for the first example,
- BMX ERT 1604 T module located in a Modicon X80 remote drop for the second example.

GET_TS_EVT_Q Implementation Example 1

Example of implementation that reads the events in a BMX CRA 312 10 module:

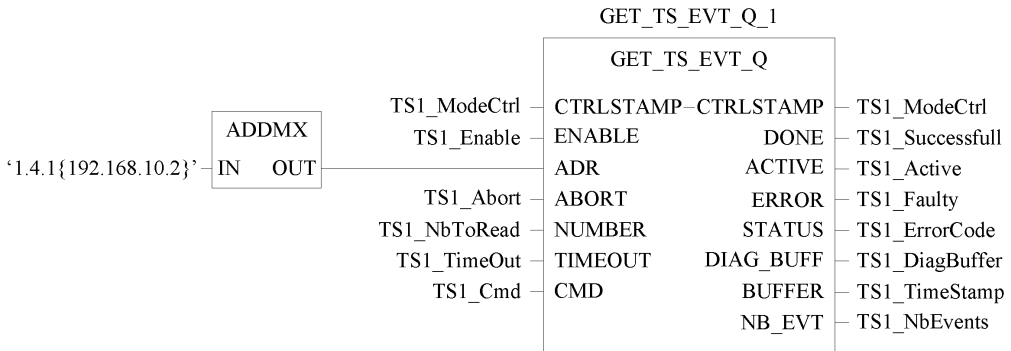

In this example the function block addresses a BMX CRA 312 10 module in a Modicon X80 remote drop. The ADDMX IN parameter value ('1.4.1{192.168.10.2}') means the following:

- 1: the 140 CRP 312 00 module (Ethernet remote I/O head) is in local rack number 1
- 4: the 140 CRP 312 00 module is in local slot number 4
- 1: the 140 CRP 312 00 module channel must be set to 1
- {192.168.10.2}: IP address of the BMX CRA 312 10 module in the Ethernet remote I/O drop

NOTE: In physical drops, slot numbering depends on the drop:

- In a Quantum physical drop, the slot number starts at 1.
- In a Modicon M340 physical drop, the slot number starts at 0.

GET_TS_EVT_Q Implementation Example 2

Example of implementation that reads the events in a BMX ERT 1604 T module located in a Modicon X80 remote drop:

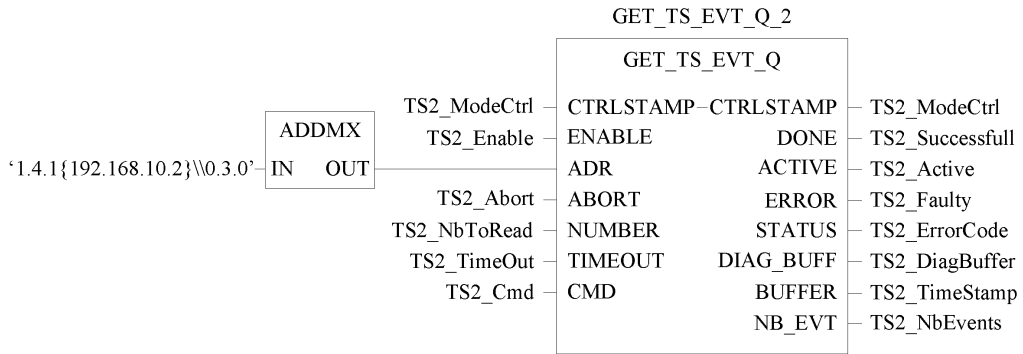

In this example, to reach the BMX ERT 1604 T module in the Modicon X80 remote drop, the first part of the ADDMX IN parameter addresses the BMX CRA 312 10 module (1.4.1 {192.168.10.2}) as in GET_TS_EVT_Q_1 example. Then, it addresses the BMX ERT 1604 T module (\0.3.0) as follows:

- 0: the module is in remote Modicon X80 rack number 0
- 3: the module is in slot number 3
- 0: communication port number, always set to 0 in a BMX ERT 1604 T module

Applicative Time Stamping Functions Representation

GET_TS_EVT_M Function

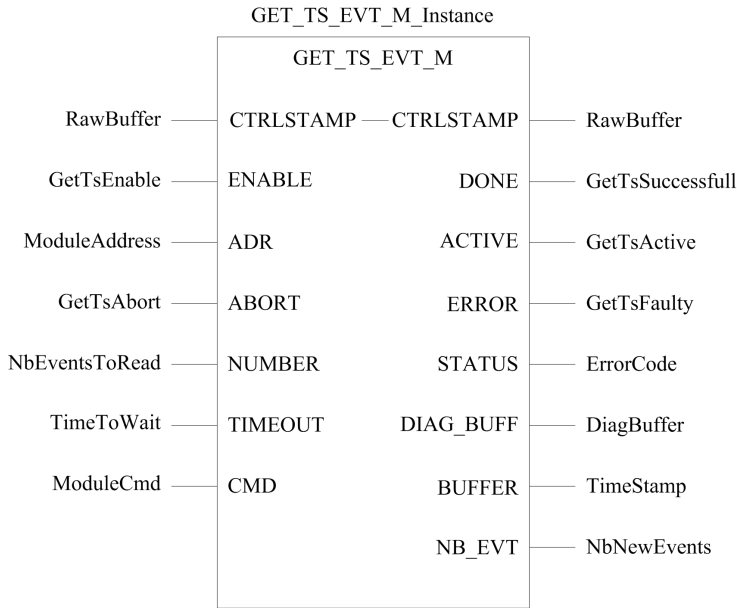

For more details on GET_TS_EVT_M function, refer to chapter *GET_TS_EVT_M: Reading Time Stamped Event Buffer* (see EcoStruxure™ Control Expert, System, Block Library).

NOTE: Use **ADDM** EF to set the Modicon M340 or Modicon M580 time stamping module local address for GET_TS_EVT_M function. ADDM EF is described in chapter *ADDM: Address Conversion* (see EcoStruxure™ Control Expert, Communication, Block Library).

NOTE: Use **ADDMX** EF to set the remote drop Modicon X80 time stamping module address for GET_TS_EVT_M function. ADDMX EF is described in chapter *ADDMX: Address Conversion* (see EcoStruxure™ Control Expert, Communication, Block Library).

NOTE: The size of the ANY_ARRAY_INT variable connected to BUFFER output parameter (Timestamp variable in previous representation) must be a multiple of 6 x INT. If the size is not a multiple of 6 x INT, a detected error is generated.

GET_TS_EVT_Q Function

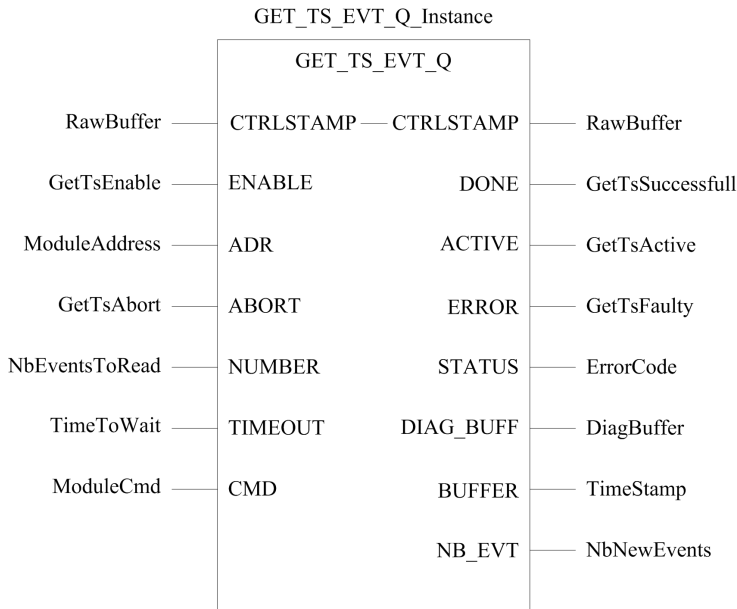

For more details on GET_TS_EVT_Q function, refer to chapter *GET_TS_EVT_Q: Reading the Quantum Time Stamped Event Buffer* (see EcoStruxure™ Control Expert, System, Block Library).

NOTE: Use **ADDMX** EF to set the remote drop Modicon X80 time stamping module address for GET_TS_EVT_Q function. ADDMX EF is described in chapter *ADDMX: Address Conversion* (see EcoStruxure™ Control Expert, Communication, Block Library).

NOTE: The size of the ANY_ARRAY_INT variable connected to BUFFER output parameter (Timestamp variable in previous representation) must be a multiple of 6 x INT. If the size is not a multiple of 6 x INT, a detected error is generated.

Commissioning and Operation Phases for Modicon M340 Modules

What's in This Part

| | |
|--|----|
| Diagnostic | 53 |
| Behavior on Operating Modes..... | 59 |
| Behavior on Time Synchronization | 65 |
| Run Time Behavior | 68 |

Introduction

This part presents the diagnostic views and behavior on operating modes.

Diagnostic

What's in This Chapter

| | |
|---------------------------------------|----|
| Time Stamping Modules Diagnostic..... | 53 |
| Data Diagnostic | 54 |
| Hardware Diagnostic..... | 56 |

Overview

This chapter describes the available diagnostic views, the diagnostic information provided by the system and the components diagnostic.

Time Stamping Modules Diagnostic

Overview

Diagnostic is understood here as the time stamping modules functional diagnostic.

Modules diagnostic is performed on Control Expert or physically on the module.

BMX ERT 1604 T Module Diagnostic in Control Expert

BMX ERT 1604 T module diagnostic is performed differently depending on the module location in the system:

- BMX ERT 1604 T placed in the local drop, diagnostic is done through:
 - the PLC language interface: %IW.r.m.0.3 to %IW.r.m.0.5. For details on implicit input parameters refer to chapter *Language Objects for Channels* (see Modicon X80, BMXERT1604T/H Time Stamp Module, User Manual).
 - or IODDT `T_ERT_TS_MOD` mapped on BMX ERT 1604 T channel 0 (%CHr.m.0). For details on BMX ERT 1604 T IODDTs refer to chapter *IODDTs* (see Modicon X80, BMXERT1604T/H Time Stamp Module, User Manual).
- BMX ERT 1604 T placed in a Modicon X80 remote drop, diagnostic is done through the PLC device DDTs. For details on those device DDTs, refer to chapter *Device DDT Names for Quantum EIO Remote I/O Adapter Modules* (see Quantum EIO, Remote I/O Modules, Installation and Configuration Guide).

BMX CRA 312 10 Module Diagnostic in Control Expert

A BMX CRA 312 10 module diagnostic is performed through the PLC device DDTs. For details on those device DDTs, refer to chapter *Device DDT Names for Quantum EIO Remote I/O Adapter Modules* (see Quantum EIO, Remote I/O Modules, Installation and Configuration Guide).

Data Diagnostic

Overview

Time stamping data diagnostic is managed by 2 types of information:

- Data exchanged implicitly with the PLC.
- Data stored in the time stamping module internal buffer (BMX ERT 1604 T or BMX CRA 312 10) with time stamped events.

Diagnostic Data Provided Through Implicit Exchanges

Information accessed through %IW or IODDT or Device DDT:

- `TS_DIAGNOSTIC_FLAGS` that contains:
 - Time valid indication (`TIME_VALID`)
 - Clock failure indication (`CLOCK_FAILURE`)
 - ClockNotSynchronized indication (`CLOCK_NOT_SYNC`)
 - Buffer full indication (`BUFF_FULL`). The bit set to 1 on buffer full detection (bit is cleared when buffer is able to store new events).
- Percentage of buffer filled (`TS_BUF_FILLED_PCTAGE`)
- Time stamping events state for internal use (`TS_EVENT_STATE`)
- SOE uncertain indication (`SOE_UNCERTAIN` is not used in applicative time stamping solution)

Diagnostic Data Contained in the Modules Internal Buffer

Each time stamped event contains an information on time quality. `TimeQuality`, page 73 is the 12th byte of each time stamped entry in the buffer and contains the following diagnostic data:

- `LeapsSecondsKnown` (BOOL type, bit 7 -preset to 0-)
- `ClockFailure` (BOOL type, bit 6)

- `ClockNotSynchronized` (BOOL type, bit 5)
- `TimeAccuracy` (5 bits code, bit 4 to 0). `TimeAccuracy` has the following meanings:
 - It represents the number of significant bits in the time stamp fraction of second (a 1ms time stamp resolution in the BMX ERT 1604 T is set with value 01010 bin).
 - It indicates the time stamp quality for `TimeQuality`, page 73 diagnostic purpose (11111 bin indicates a non periodical time stamping detection cycle, 11110 bin indicates an invalid time, 11101 bin indicates an I/O channel detected error, 11100 bin indicates an initialization in process, 11011 bin indicates that the clock is in synchronization phase).

The BMX ERT 1604 T module provides an event with ID 16 (`SOE_UNCERTAIN`) to indicate that some events may be lost in the next sequence of events.

Diagnostic Data Contained in the GET_TS_EVT_X Function Block Parameter

`GET_TS_EVT_X` function blocks have an output `STATUS` parameter that provides reports on communication (exchange, address, buffer size) and function block operation (PLC buffer, time stamping module buffer, user parameters consistency during function block execution). Details on `STATUS` parameter are provided in `GET_TS_EVT_M`: Reading the Modicon M340 Time Stamped Event Buffer (see *EcoStruxure™ Control Expert, System, Block Library*) and `GET_TS_EVT_Q`: Reading the Quantum Time Stamped Event Buffer (see *EcoStruxure™ Control Expert, System, Block Library*) chapters.

Diagnostic Data Contained in Device DDT Information

Time stamping source modules located in a Modicon X80 remote drop manage device DDT diagnostic parameters. Details on those device DDTs are provided in chapter *Device DDT Names for Quantum EIO Remote I/O Adapter Modules* (see *Quantum EIO, Remote I/O Modules, Installation and Configuration Guide*).

Diagnostic Data Contained in Language Interface Information

A BMX ERT 1604 T module in a Modicon M340 local drop manage diagnostic parameters with implicit input parameters. Details on those implicit input parameters are provided in chapter *Language Objects for Channels* (see *Modicon X80, BMXERT1604T/H Time Stamp Module, User Manual*).

Hardware Diagnostic

BMX ERT 1604 T Module View

Module front view:

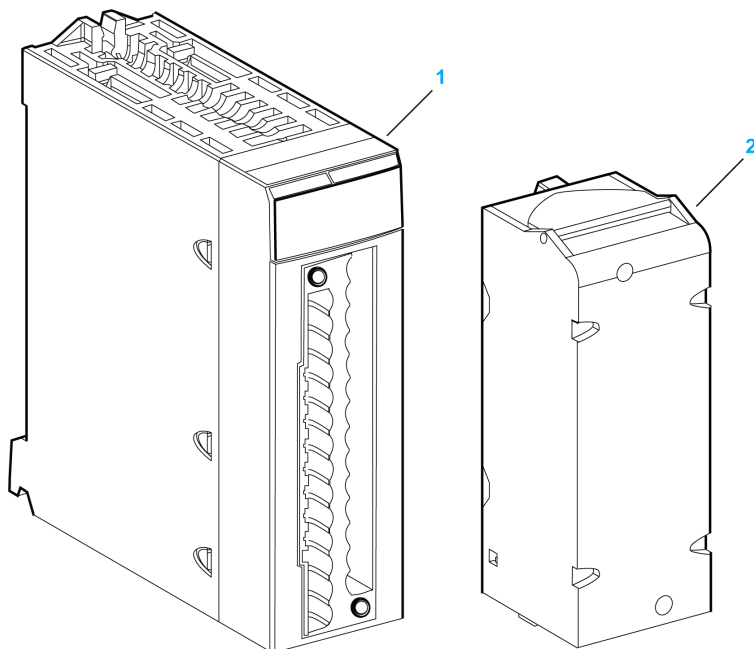

1 Module with its LED display

2 28-pin removable terminal block

LED display:

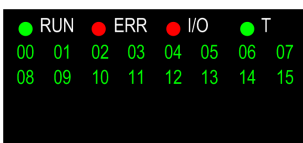

The following table describes the LED display activity meaning for diagnostic purpose:

| LED | Status | Description |
|-----|--------------------|--|
| ERR | ON | The module has an internal detected error. |
| | Flashing | The module is not configured. |
| | (with RUN LED OFF) | The module is configuring its channels. |

| LED | Status | Description |
|------------|--|---|
| | Flashing (with RUN LED ON) | The module has lost the communication with the PLC CPU. |
| I/O | ON | Field power supply failure detected. |
| T | ON | The module clock is synchronized with the external time source connected. |
| | Flashing (with RUN LED Flashing) | Firmware is being downloaded. |
| | Quick flashing | Module clock synchronization error detected: External time clock is temporarily unstable but the internal time quality is acceptable. |
| | OFF | No external time source input. |

BMX CRA 312 10 Module View

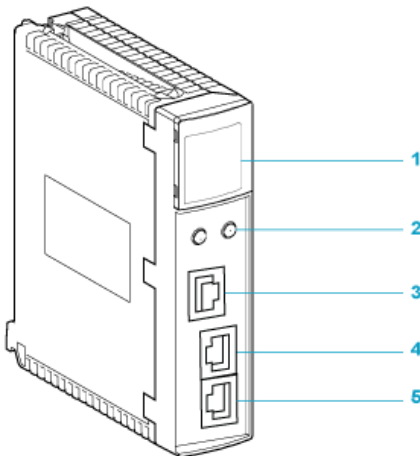

1 LED display

2 rotary switches

3 SERVICE port (ETH 1)

4 DEVICE NETWORK port (ETH 2)

5 DEVICE NETWORK port (ETH 3)

The following table describes the LED display activity meaning for diagnostic purpose:

| LED | Status | Description |
|-----|----------|---|
| I/O | ON | External fault detected when the module is configured or non-recoverable error detected. |
| | | I/O error detected from a module or a channel in the remote drop while in configured or in RUN state. |
| | | Configuration error detected while configured or in RUN state. |
| | Flashing | BMX CRA 312 10 power on. |
| | | Duplicated IP address set. |

Behavior on Operating Modes

What's in This Chapter

| | |
|---|----|
| Introduction | 59 |
| Start and Power Down/up of a Time Stamping Module | 61 |
| Replacement of a Time Stamping Module | 61 |
| Behavior on Buffer Full | 62 |

Overview

This chapter describes the system behavior during the different operating mode phases.

Introduction

Time Stamping Events State Description

Time stamping module buffer state diagram:

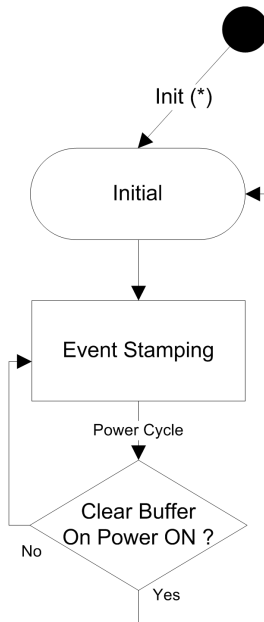

Time stamping events states description:

| | |
|-----------------|--|
| Initial: | Initialization of the source time stamping events context (buffers, indexes...). |
| Event Stamping: | Detection and storage of source time stamping variables changes. |

Time stamping events transitions description:

| | |
|-------------|---|
| Init(*): | <p>The meaning depends on the time stamping module location:</p> <ul style="list-style-type: none"> • PLC local drop: global application download, cold start. • Modicon X80 drop: Power on with a new time stamping events context, new configuration download. |
| Power Cycle | <p>The meaning depends on the time stamping module location:</p> <ul style="list-style-type: none"> • PLC local drop: Warm start. • Modicon X80 drop: Power on with the same time stamping events context (assuming that the context has previously been saved on power off). |

NOTE: Previous diagram is valid for time stamping with BMX CRA 312 10 module. In the case of the BMX ERT 1604 T module, refer to *Behavior Mode* (see Modicon X80, BMXERT1604T/H Time Stamp Module, User Manual) topic.

PLC Operating Modes

The following table describes the actions on time stamping module and PLC buffers on operating mode transitions:

| Transition | Time Stamping Modules Internal Buffer | | PLC Buffer |
|-------------|--|---|---|
| | BMX ERT 1604 T | BMX CRA 312 10 | Event Raw Buffer |
| Cold Start | New events are added to the existing events buffer if the time stamping application is the same. | <ul style="list-style-type: none"> • Events buffer is cleared, or • New events are added to the existing events buffer if the time stamping application is the same. (1.) | <p>PLC buffers are cleared.</p> <p>NOTE: On application download, PLC buffers are also cleared</p> |
| Warm Start | New events are added to the existing events buffer if the time stamping application is the same | <ul style="list-style-type: none"> • Events buffer is cleared, or • New events are added to the existing events buffer if the time stamping application is the same. (1.) | <p>PLC memory is kept and PLC buffer behavior depends on GET_TS_EVT_X function block parameter (Operating MODE value in CTRL_STAMP parameter).</p> |
| Stop to Run | New events are added to the existing events buffer. | <ul style="list-style-type: none"> • Events buffer is cleared, or • New events are added to the existing events buffer if the time stamping application is the same. (1.) | <p>PLC memory is kept and PLC buffer behavior depends on GET_TS_EVT_X function block parameter (Operating MODE value in CTRL_STAMP parameter).</p> |
| 1. | Buffer behavior depends on BMX CRA 312 10 module settings, page 42. | | |

Start and Power Down/up of a Time Stamping Module

Initial Start After Application Download

After the application download, each time stamping module:

- Gets its configuration from the PLC.
- Events remaining in the time stamp source module before the application download are deleted if the time stamping application is different.
- Synchronizes its internal time with the time reference (GPS clock, DCF77 or NTP server).
- Stores time stamping events on declared I/O value changes.

NOTE: While the clock is not synchronized, stamped events are marked with a `CLOCK_NOT_SYNC` or `CLOCK_FAILURE` parameter, page 65.

Power Down/Up of a Time Stamping Module

The following sequence describes the steps followed on a time stamping module power up, after a power down while the system is running correctly with the time stamping module working properly and without application changes:

- Time stamping module gets its configuration from the PLC.
- Time stamping module synchronizes its internal time with the time reference (GPS clock, DCF77 or NTP server).
- Time stamping module stores time stamping events.
- Events stored in the time stamping source module buffer before the power up are read by the PLC with the execution of `GET_TS_EVT_X` function block.

NOTE: In a BMX CRA 312 10 module, events before power up may be cleared if such a behavior is configured.

NOTE: While the clock is not synchronized, stamped events are marked with a `CLOCK_NOT_SYNC` or `CLOCK_FAILURE` parameter, page 65.

Replacement of a Time Stamping Module

Procedure

Refer to each specific module user guide for more information on module replacement.

Behavior on Buffer Full

Buffers Definition

2 types of buffers are to be considered:

- Time stamping module internal buffer. This buffer parameters are set in Control Expert for the BMX ERT 1604 T, page 39 and BMX CRA 312 10, page 42 modules.
- PLC event raw buffer, set in GET_TS_EVT_X function block (CTRL_STAMP parameter, page 70)

Time Stamping Module Internal Buffer Behavior on Buffer Full

A time stamping module internal buffer should not be full in normal case, but, it can become full in case of disconnection between the module and the PLC for example.

A buffer full is diagnosed via `BUFF_FULL` and `TS_BUF_FILLED_PCTAGE` parameters, page 54.

Time stamping modules behavior on internal buffer full:

- BMX ERT 1604 T stops the recording on buffer full. The process value changes are lost until the system is working normally again.
- BMX CRA 312 10 offers 2 possibilities:
 - Stop the recording on buffer full, the process value changes are lost until the system is working normally again.
 - Overwrite buffer on buffer full, the oldest value changes are lost until the system is working normally again.

Buffer Full Event Sequence

NOTE: The BMX ERT 1604 T module buffer behavior is specific. For more details, refer to *Behavior Mode* (see Modicon X80, BMXERT1604T/H Time Stamp Module, User Manual) topic

The following diagram explains the BMX CRA 312 10 buffer management in the applicative time stamping solution:

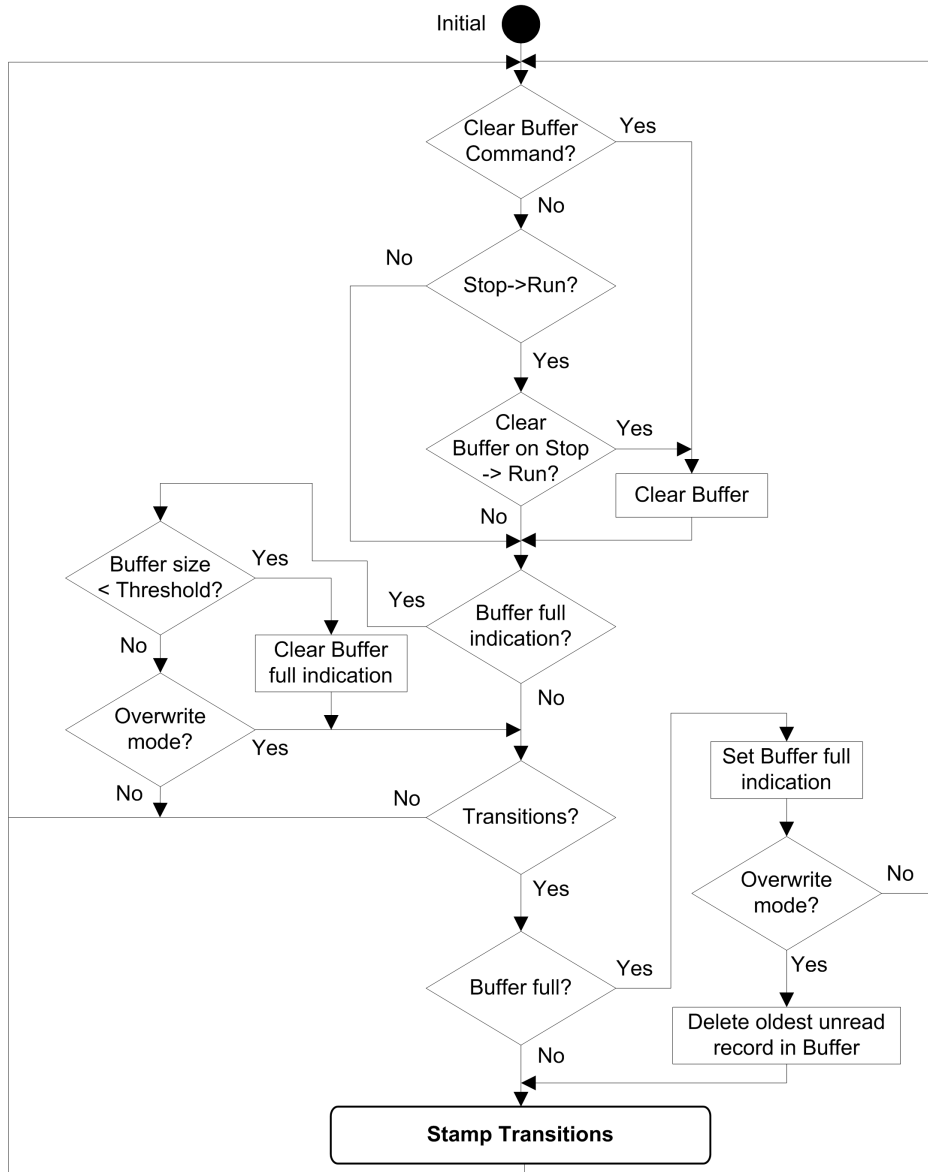

Clear BMX ERT 1604 T Internal Buffer

If the internal module buffer needs to be cleared for another application, use one of the following solutions depending on the module location:

- BMX ERT 1604 T in the PLC (local drop):
 - Execute GET_TS_EVT_M function block with `CMD` input parameter set to 1, or
 - Set %Qr.m.0.0 or `CLR_EVENT_BUF` in `T_ERT_TS_MOD` parameter in `IODDT` instance to 1
- BMX ERT 1604 T in a Modicon X80 drop:
 - Execute GET_TS_EVT_Q function block with `CMD` input parameter set to 1, or
 - Set `T_M_TIME_SYNC_ERT.CLR_EVT_BUF` parameter in `T_M_DIS_ERT` device `DDT` instance to 1

NOTE: The internal buffer may also be cleared according to the corresponding operating mode behavior, page 60.

NOTE: The execution of `GET_TS_EVT_X` function block empties the time stamping module internal buffer by reading its events.

Clear BMX CRA 312 10 Internal Buffer

The execution of `GET_TS_EVT_Q` function block with `CMD` input parameter set to 1 clears the time stamping module internal buffer.

NOTE: The internal buffer may also be cleared according to the corresponding operating mode behavior, page 60.

NOTE: The execution of `GET_TS_EVT_Q` function block empties the time stamping module internal buffer by reading its events.

Behavior on Time Synchronization

What's in This Chapter

| | |
|---------------------------|----|
| Time Synchronization..... | 65 |
|---------------------------|----|

Overview

This chapter describes the time synchronization mechanism.

Time Synchronization

Time Synchronization on System Start

On system start, the time stamping modules begin to time stamp events without waiting for the initial time synchronization.

To manage that situation, `CLOCK_NOT_SYNC` or `CLOCK_FAILURE` parameter is set to 1. The same information is available in the time stamp event buffer: `ClockNotSynchronized` or `ClockFailure` set to 1 in `TimeQuality`, page 73 byte.

Once the time stamping module time is synchronized, `CLOCK_NOT_SYNC` and `CLOCK_FAILURE` parameters are set to 0 (or `ClockNotSynchronized` and `ClockFailure` set to 0 in `TimeQuality` byte).

Time Synchronization When the System Is Running

When the system is running, each time stamping module synchronizes periodically its clock with the external clock reference. On synchronization, 3 situations appear:

- Module internal time is equal to external clock time.
No change in module internal time.
- Module internal time is delayed compared to external clock time.
Module internal time synchronizes with external clock time.
- Module internal time is ahead of external clock time.

Module internal time synchronizes with external clock time in the following way:

- Module internal time is ahead of external clock time while the Device DDT status of BM• CRA 312 10 is: `TIME_VALID=1CLOCK_FAILURE=0CLOCK_NOT_SYNC=0`.

- Catch-up mechanism is used to keep time coherence in sequence of events (event n+1 cannot be earlier than event n) and to minimize the time increment recorded in the next timestamp time value:

$$\text{Catch-up time} = (\text{Internal time} - \text{Synchronized time received}) \times \text{Detection cycle} / (\text{Detection cycle} - \text{Incrementation step})$$

NOTE: “Catch-up time”: the time required to synchronize the time stamp value with the new internal time.

Synchronization mechanism until module internal time > last time stamp value (internal time cannot be accessed by the user):

- Every time stamping detection cycle, the time stamp value increments by the maximum of:
 - 1 ms; or
 - Detection cycle time (in a BMX ERT 1604 T module, increment value is 1 ms)
- The catch-up mechanism activity can be diagnosed in the `TimeQuality` byte when `TimeAccuracy = ClockInSync (0xx11011 bin)`.

The following figure illustrates the synchronization mechanism when the internal time is ahead of external clock time (5 ms time stamping detection cycle and 1 ms incrementation step):

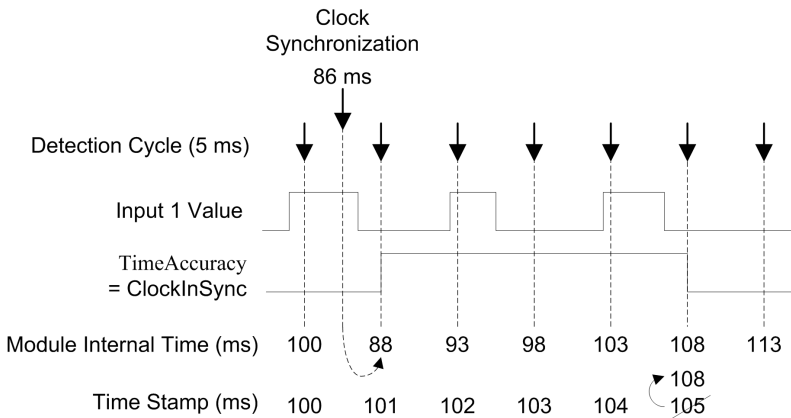

The following table explains the sequence of events and time values shown in previous picture:

| Event | Time Stamp (ms) | Module internal Time (ms) | TimeQuality | Comment |
|-----------------|-----------------|---------------------------|----------------------------------|---|
| Input 1: 0 -> 1 | 100 | 100 | <code>TimeAccuracy = 1 ms</code> | |
| No Event | N.A. | 86 ms | N.A. | External clock synchronization value received |

| Event | Time Stamp (ms) | Module internal Time (ms) | TimeQuality | Comment |
|---------------------|-----------------|---------------------------|----------------------------|---|
| Input 1: 1 -> 0 | 101 | 88 ms | TimeAccuracy = ClockInSync | internal Time (n) < Time Stamp (n-1) => Time Stamp (n) = Time Stamp (n-1) + 1 ms |
| Input 1: 0 -> 1 | 102 | 93 ms | TimeAccuracy = ClockInSync | internal Time (n) < Time Stamp (n-1) => Time Stamp (n) = Time Stamp (n-1) + 1 ms |
| Input 1: 1 -> 0 | 103 | 98 ms | TimeAccuracy = ClockInSync | internal Time (n) < Time Stamp (n-1) => Time Stamp (n) = Time Stamp (n-1) + 1 ms |
| Input 1: 0 -> 1 | 104 | 103 ms | TimeAccuracy = ClockInSync | internal Time (n) < Time Stamp (n-1) => Time Stamp (n) = Time Stamp (n-1) + 1 ms |
| Input 1: 1 -> 0 | 108 | 108 ms | TimeAccuracy = 1 ms | internal Time (n) > Time Stamp (n-1) => Time Stamp (n) = internal Time (n) |
| N.A. Not Applicable | | | | |

In this example: Catch up time = $(100 - 86) \times 5 / (5 - 1)$. Catch up time = 17.5 ms (around 4 detection cycles of 5 ms).

Time Synchronization Lost When the System is Running

If the time synchronization is lost (no link with the external time reference), the time stamping module time stamps events with its internal time based on the latest successful synchronization.

NOTE: If the time has never been synchronized, then the internal time is the free running time from epoch.

As in the initial start case, to manage that situation, `CLOCK_NOT_SYNC` parameter is set to 1 (and `ClockNotSynchronized` set to 1 in `TimeQuality` byte).

Once the time stamping module time is synchronized, `CLOCK_NOT_SYNC` parameter is set to 0 (and `ClockNotSynchronized` set to 0 in `TimeQuality` byte).

Run Time Behavior

What's in This Chapter

| | |
|---|----|
| Function Blocks Programming Rules | 68 |
| Event Time Stamp Entry | 72 |

Overview

This chapter describes time stamping specific EFB programming rules.

Function Blocks Programming Rules

Time Stamping Function Blocks

2 function blocks are used for time stamping application:

- GET_TS_EVT_M
- GET_TS_EVT_Q

Each GET_TS_EVT_X function block fills a ring buffer in the PLC with the event time stamp entries, page 72 from the time stamping source modules. This buffer is emptied when reading with the user application.

NOTE: The size of the ring buffer must be a multiple of 6 x INT.

Starting the Function Block

GET_TS_EVT_X instance is started when it is called in the user application.

The execution of the function block instance is evaluated at each call in the application.

Values of the function block parameters must not be changed between 2 calls of the same instance. The EFB execution, page 69 must be completed successfully before modifying parameters.

Stopping the Function Block

The completion of the current operation performed by GET_TS_EVT_X function block is reached when:

- Maximum number of events is reached in the buffer.

- Buffer is full for the BMX ERT 1604 T module and BMX CRA 312 10 with buffer mode configured to stop the recording on buffer full, page 42.
- An error is detected.

Once GET_TS_EVT_X EFB execution is finished, `ACTIVE` parameter is set to 0, page 69.

Operating Mode of Enable, Active, Done and Error Parameters

The `ENABLE`, `ACTIVE`, `DONE` (or `SUCCESS`) and `ERROR` parameters operate as follows:

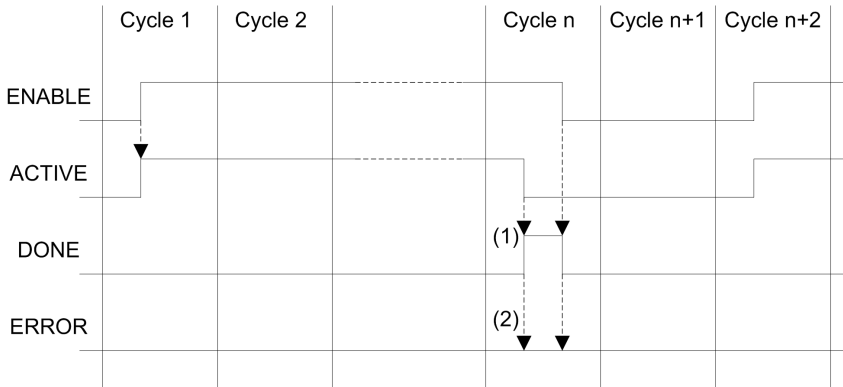

(1) `DONE` = 1 if no error, `DONE` = 0 if error

(2) `ERROR` = 0 if no error, `ERROR` = 1 if error

The `ENABLE` parameter is written by the application.

The `ACTIVE`, `DONE` and `ERROR` parameters are read by the application.

To launch the communication function only once, the `ENABLE` signal needs to be reset to 0 once the `ACTIVE` parameter is set to 0. If the `ENABLE` parameter is maintained to 1 once the `ACTIVE` parameter is set to 0, the communication function is launched again and the `ACTIVE` parameter will be set to 1 on the next cycle.

Reading the events in the time stamping sources (BMX ERT 1604 T and BMX CRA 312 10 modules) may require several PLC cycles. Each function block is controlled with the `ENABLE` parameter, page 69.

Rules to follow when setting the `ENABLE` parameter value:

- When GET_TS_EVT_X function block is not active, all input parameters must be initialized before setting `ENABLE` to 1, and not be changed during the function block activity.
- If `ENABLE` parameter is maintained to 1 after the execution of the function block, GET_TS_EVT_X function block continues to fill the buffer using current value of `BEGIN` and `END` indexes.

- If `ENABLE` parameter is set to 0 before the `GET_TS_EVT_X` function block execution is completed successfully (`ACTIVE = 0`), the function block is stopped.

GET_TS_EVT_X Buffer and CTRLSTAMP Parameter Description

`CTRL_STAMP` DDT structure example and link with the PLC buffer:

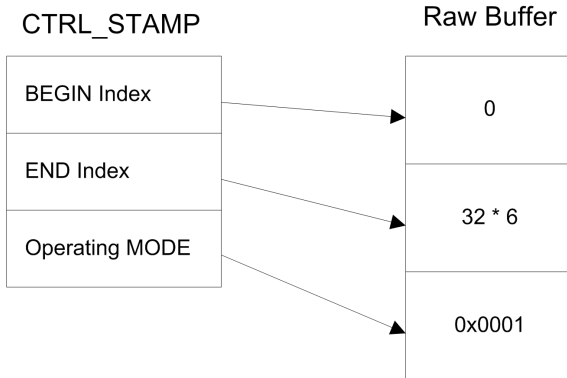

The example above shows the `CTRL_STAMP` content after writing 32 events (1 event entry is 6 words long) in the PLC buffer configured as follows:

- PLC buffer is located and there are 32 events to write
- Stop the recording when the buffer is full and continue with the previous value on power on.

`Operating MODE` word structure:

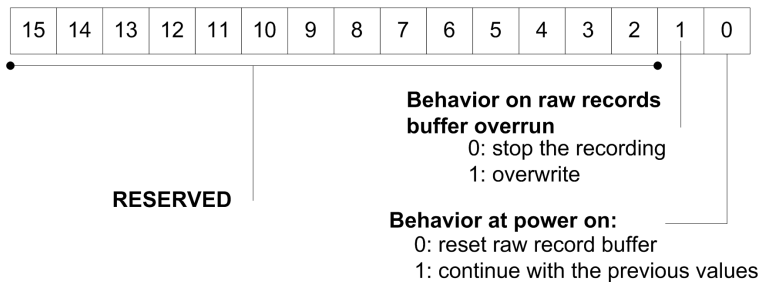

Buffer level:

- If `BEGIN Index = END Index` then the buffer is empty
- If `END Index + 6 = BEGIN Index` then the buffer is full (in the preceding equation, 6 represents the size of 1 event). The buffer is full when there is one space left for 1 event (6 x INT).

EFB behavior on buffer full depends on the `Operating MODE` parameter, bit 1 value:

- If **Behavior on raw records buffer overrun** is set to 0 (stop the recording), the buffer is not filled with new data.
- If **Behavior on raw records buffer overrun** is set to 1 (overwrite buffer), older data is overwritten with newer data. In this case, the EFB updates both BEGIN Index and END Index.

Communicating with Remote Ethernet Drops

When a communication function is used to perform communication exchanges with Ethernet drops, it is highly advisable to test the communication health status of the Ethernet drop before launching the communication function.

A communication function addressed to a non responding drop may take up to 2 minutes to complete, ending with an error status due to the transaction timeout delay (the remote participant has not answered within the timeout delay).

NOTE: The execution of communication functions may be slowed down if all communication ports are already used by communication functions.

Communication health status is checked by one of those 2 information:

- %SW172 to %SW173 (see EcoStruxure™ Control Expert, System Bits and Words, Reference Manual). Ethernet RIO drop detected communication error status. A bit in those status words is set to 0 when the corresponding connection between the PLC and the drop is not operating properly.
- or DROP_COM_HEALTH (see Quantum EIO, Remote I/O Modules, Installation and Configuration Guide). Field in the DDT structure associated with a drop.

Building the Application

When building an application with time stamping function, the following checks are performed by Control Expert:

- Time stamped alias have to be linked to time stamped variables otherwise a detected error message is raised.
- A time stamped variable has to be located on a time stamping source module or on a discrete module located in a drop with a BMX CRA 312 10 otherwise a detected error message is raised.
- Device DDT with time stamped variables are correctly managed otherwise a detected error message is raised.
- If the system includes a BMX CRA 312 10 module in an Ethernet I/O drop, an NTP server address must be configured.
- Maximum amount of time stamped variables per drop with a BMX CRA 312 10 module is not exceeded.
- Maximum amount of time stamped variables for the whole system is not exceeded.

- Maximum amount of BMX ERT 1604 T modules for the whole system is not exceeded.
- Components versions are compatible with time stamping function.
- If channels are set to assume time stamping in a BMX ERT 1604 T module, a clock must be connected to the module. If no clock signal is detected, a detected error message is raised.
- polling period, page 38 should be lower than 20 seconds otherwise a message is raised at build time.
- Dynamic arrays must be enabled otherwise a detected error message is raised.

Event Time Stamp Entry

Event Data Format

Each event time stamp entry is a 12 bytes block organized as follows:

| | | | |
|---------------------|------------------|-------------|--------|
| Reserved (set to 0) | | Byte 0 | |
| Value | | Byte 1 | |
| Event ID | | Bit 7...0 | Byte 2 |
| | | Bit 15...8 | Byte 3 |
| DateAndTime | SecondSinceEpoch | Bit 7...0 | Byte 4 |
| | | Bit 15...8 | Byte 5 |
| | | Bit 23...16 | Byte 6 |
| | | Bit 31...24 | Byte 7 |
| | FractionOfSecond | Bit 7...0 | Byte 8 |
| | | Bit 15...8 | Byte 9 |
| Bit 23...16 | | Byte 10 | |
| TimeQuality | | Byte 11 | |

Each parameter is detailed hereunder.

Value Parameter

Bit 0 defines the value of the variable after change detection:

- 0: Falling edge
- 1: Rising edge

Event ID Parameter

It represents the topological address of the channel in a BMX ERT 1604 T module (with Event ID = 16 attributed to the SOE UNCERTAIN) and is provided by the variable management as a unique value for the BMX CRA 312 10 modules.

DateAndTime Parameter

Defines the date and time of the variable change detection.

The following table describes the `DataAndTime` parameter format:

| Attribute Name | Type | Description/Value | Position |
|--------------------------------|--------|---|-----------------------------|
| <code>SecondsSinceEpoch</code> | INT32U | Number of seconds since midnight (00:00:00) 1970/01/01 (UTC time). (0...MAX) | |
| <code>FractionOfSecond</code> | INT24U | FRACT_SEC_0 (LSByte) | B7-B0 |
| | | FRACT_SEC_1 | B15-B8 |
| | | FRACT_SEC_2 (MSByte) | B23-B16 (B23 = 1 for 1/2 s) |

The time format is defined according to *IEC 61850-7-2 Edition 2*.

Representation of the `FractionOfSecond` parameter structure:

| FRACT_SEC_2 (MSByte) | | | | | | | | FRACT_SEC_1 (2nd byte) | | | | | | | FRACT_SEC_0 (LSByte) | | | | | | | | |
|----------------------|-----|-----|-----|-----|-----|-----|-----|------------------------|-----|-----|-----|-----|-----|---|----------------------|---|---|---|---|---|---|---|---|
| 2-3 | 2-2 | 2-1 | 2-0 | 1-9 | 1-8 | 1-7 | 1-6 | 1-5 | 1-4 | 1-3 | 1-2 | 1-1 | 1-0 | 9 | 8 | 7 | 6 | 5 | 4 | 3 | 2 | 1 | 0 |

TimeQuality Parameter

The following table describes the `TimeQuality` parameter format:

| Attribute Name | Type | Description/Value |
|--------------------------------|--------------|---|
| <code>LeapsSecondsKnown</code> | BOOLEAN (B7) | This bit is set to FALSE. |
| <code>ClockFailure</code> | BOOLEAN (B6) | Same meaning as I% (implicit variable) <code>CLOCK_FAILURE</code> . |

| Attribute Name | Type | Description/Value |
|----------------------|----------------------|--|
| ClockNotSynchronized | BOOLEAN (B5) | Same meaning as the I% (implicit variable) CLOCK_NOT_SYNC. |
| TimeAccuracy | CODED ENUM (B4...B0) | <p>Number of significant bits in the FractionOfSecond.</p> <p>Minimum time interval is: 2**n.</p> <p>In IEC norm, the TimeAccuracy represents the number of significant bits N in the FractionOfSecond.</p> <ul style="list-style-type: none"> For the 1 ms time stamp resolution of BMXERT module, TimeAccuracy is set to 0xx01010 bin. If ClockNotSynchronized = 1, or if ClockFailure = 1 the TimeAccuracy keeps its usual value (as if the clock is synchronized). |

TimeAccuracy is also used to set specific values of TimeQuality as described in the following table:

| TimeAccuracy Specific Values | Values | Comments |
|------------------------------|----------|--|
| Unspecified | 0xx11111 | Used in case of time stamping detection cycle not periodic |
| Time invalid | 0xx11110 | Used in case of buffer full |
| IO Channel error | 0xx11101 | Used in case of IO Channel error detection |
| TSInit | 0xx11100 | Used in case of synchronization of the values with the client (done by storing a virtual event with 16-ch discrete values inside the buffer) |
| ClockInSync | 0xx11011 | Used in case of external clock during synchronization (catch up mode) |

If several errors are detected, the precedence of TimeAccuracy specific values are:

1. TimeAccuracy = IOChannelError (highest priority)
2. TimeAccuracy = Invalid or TSInit
3. TimeAccuracy = ClockInSync
4. TimeAccuracy = Unspecified

Quantum Modules for Applicative Time Stamping

What's in This Part

| | |
|---|----|
| 140 ERT 854 +0 Modules Implementation | 76 |
|---|----|

140 ERT 854 •0 Modules Implementation

What’s in This Chapter

140 ERT 854 •0 Modules76

140 ERT 854 •0 Modules

140 ERT 854 •0 Detailed Information

Details on the 140 ERT 854 •0 time stamping modules are provided in the *Quantum using EcoStruxure™ Control Expert, 140 ERT 854 10 Time Stamp Module, User Manual* and *Quantum using EcoStruxure™ Control Expert, 140 ERT 854 20 Time Stamp Module, User Manual*.

Programming Rules and Run Time Behavior

Applicative time stamping with 140 ERT 854 •0 modules is managed by:

- ERT_854_10 function block (see *Quantum using EcoStruxure™ Control Expert, 140 ERT 854 10 Time Stamp Module, User Manual*) for the 140 ERT 854 10 module
- ERT_854_20 function block (see *Quantum using EcoStruxure™ Control Expert, 140 ERT 854 20 Time Stamp Module, User Manual*) for the 140 ERT 854 20 module

In a safety Quantum application, the applicative time stamping with 140 ERT 854 20 module is managed by the NI_ERT_854_20 function block (see *Quantum using EcoStruxure™ Control Expert, 140 ERT 854 20 Time Stamp Module, User Manual*).

Appendices

What's in This Part

| | |
|------------------|----|
| Error Codes..... | 78 |
|------------------|----|

Error Codes

What's in This Chapter

| | |
|------------------|----|
| Error Codes..... | 78 |
|------------------|----|

Error Codes

Function Blocks Error Codes

GET_TS_EVT_X function block can generate error codes during their execution.

For more details on GET_TS_EVT_M error codes, refer to chapter *GET_TS_EVT_M: Reading the Modicon M340 Time Stamped Event Buffer* (see EcoStruxure™ Control Expert, System, Block Library).

For more details on GET_TS_EVT_Q error codes, refer to chapter *GET_TS_EVT_Q: Reading the Quantum Time Stamped Event Buffer* (see EcoStruxure™ Control Expert, System, Block Library).

Glossary

A

architecture:

A framework for the specification of a network, constructed on the following:

- Physical components and their functional organization and configuration.
- Operational principles and procedures.
- Data formats used in its operation.

C

CCOTF:

Change Configuration On The Fly. A Quantum function that allows to change values while the PLC is running.

E

Ethernet/IP:

A network communication protocol for industrial automation applications that combines the standard internet transmission protocols of TCP/IP and UDP with the application layer common industrial protocol (CIP) to support both high-speed data exchange and industrial control. Ethernet/IP employs electronic data sheets (EDS) to classify each network device and its functionality.

Ethernet:

A 10 Mb/s, 100 Mb/s, or 1 Gb/s, CSMA/CD, frame-based LAN that can run over copper twisted pair or fiber optic cable, or wireless. The IEEE standard 802.3 defines the rules for configuring a wired Ethernet network; the IEEE standard 802.11 defines the rules for configuring a wireless Ethernet network. Common forms include 10BASE-T, 100BASE-TX, and 1000BASE-T, which can utilize category 5e copper twisted pair cables and RJ45 modular connectors.

G

GPS:

Global Positioning System. The GPS standard positioning service consists of a space-based positioning, navigation, and timing signals delivered worldwide for civil and military use. Standard positioning service performance depends on satellites broadcast signal parameters, GPS constellation design, the number of satellites in sight and various environmental parameters.

H

HMI:

Human Machine Interface. An HMI is a device that displays process data to a human operator, who in turn, uses the HMI to control the process.

An HMI is typically connected to a SCADA system to provide diagnostics and management data (such as scheduled maintenance procedures and detailed schematics for a particular machine or sensor).

Hot Standby:

A high-availability Quantum control system with a first PLC (primary) and a second PLC (standby) that maintains up-to-date system status. If the primary PLC becomes inoperable, the standby PLC takes control of the system.

O

OFS :

OPC Factory Server. OFS is a multi-controller data server which is able to communicate with PLCs in order to supply the OPC clients with data.

OLE:

Object Linking and Embedding

OPC DA:

OLE for Process Control Data Access. OPC DA is a group of standards that provides specifications for communicating real-time data.

OPC:

OLE for Process Control

S**SCADA:**

Supervisory Control and Data Acquisition. SCADA usually refers to centralized systems which monitor and control entire sites or systems spread out over large areas.

Vijeo Citect versions from V7.30 provide an SOE view.

For system time stamping, it refers to Vijeo Citect or 3rd party SCADA with OPC DA interface.

SOE:

Sequence Of Events

Index

| | |
|-----------------------------------|----|
| 140 ERT 854 10 Implement | 76 |
| 140 ERT 854 20 Implement | 76 |

A

| | |
|---------------------------------|----|
| activate service | 29 |
| ADDM function block | 45 |
| ADDMX function block | 45 |
| applicative time stamping | 12 |
| architecture typical | 21 |

B

| | |
|-------------------------------------|----|
| buffer full operating mode | 62 |
| build | 71 |

C

| | |
|---------------------|----|
| commissioning | 52 |
| diagnostic | 53 |
| components | 16 |

D

| | |
|-----------------------------------|----|
| diagnostic commissioning | 53 |
|-----------------------------------|----|

F

| | |
|------------------------------|--------|
| function block ADDM | 45 |
| ADDMX | 45 |
| GET_TS_EVT_M | 45, 68 |
| GET_TS_EVT_Q | 45, 68 |

G

| | |
|--------------------------------------|--------|
| GET_TS_EVT_M function block | 45, 68 |
| GET_TS_EVT_M example | 45 |
| GET_TS_EVT_Q function block | 45, 68 |
| GET_TS_EVT_Q example | 47 |

I

| | |
|---------------------------------------|----|
| Implement 140 ERT 854 10 | 76 |
| 140 ERT 854 20 | 76 |
| initial start operating mode | 61 |

M

| | |
|------------------------|----|
| module select | 32 |
|------------------------|----|

O

| | |
|----------------------|----|
| operating mode | 59 |
| buffer full | 62 |
| initial start | 61 |
| power down/up | 61 |

P

| | |
|---------------------------------------|----|
| power down/up operating mode | 61 |
|---------------------------------------|----|

R

| | |
|--------------------------------|----|
| resolution time stamp | 32 |
|--------------------------------|----|

S

| | |
|----------------------------|----|
| select module | 32 |
| time source | 34 |
| time synchronization | 34 |

- variables 39
- service
 - activate 29
- synchronization
 - time 65

T

- time
 - synchronization 65
- time source
 - select 34
- time stamp
 - resolution 32
 - variables 39
- time stamping 12
- time synchronization
 - select 34
- typical
 - architecture 21

V

- variables
 - select 39
 - time stamp 39
- version 20

Schneider Electric
35 rue Joseph Monier
92500 Rueil Malmaison
France

+ 33 (0) 1 41 29 70 00

www.se.com

As standards, specifications, and design change from time to time, please ask for confirmation of the information given in this publication.

© 2022 Schneider Electric. All rights reserved.

EIO0000001268.05