

R88D-GN□, R88D-GT□

G-Series servo drive

A compact servo drive family for motion control. Compact size and integrated MECHATROLINK-II motion bus.

- ML2 and Analog/ Pulse servo drive models
- High-response frequency of 1 kHz
- Auto-tuning for easy and quick start-up
- Vibration suppression
- Positioning, speed or torque control
- Separate power and control power supply
- Fast and accurate positioning
- Incremental and absolute encoder

Ratings

- 230 VAC Single-phase 100 W to 1.5 kW (8.62 Nm)



System configuration

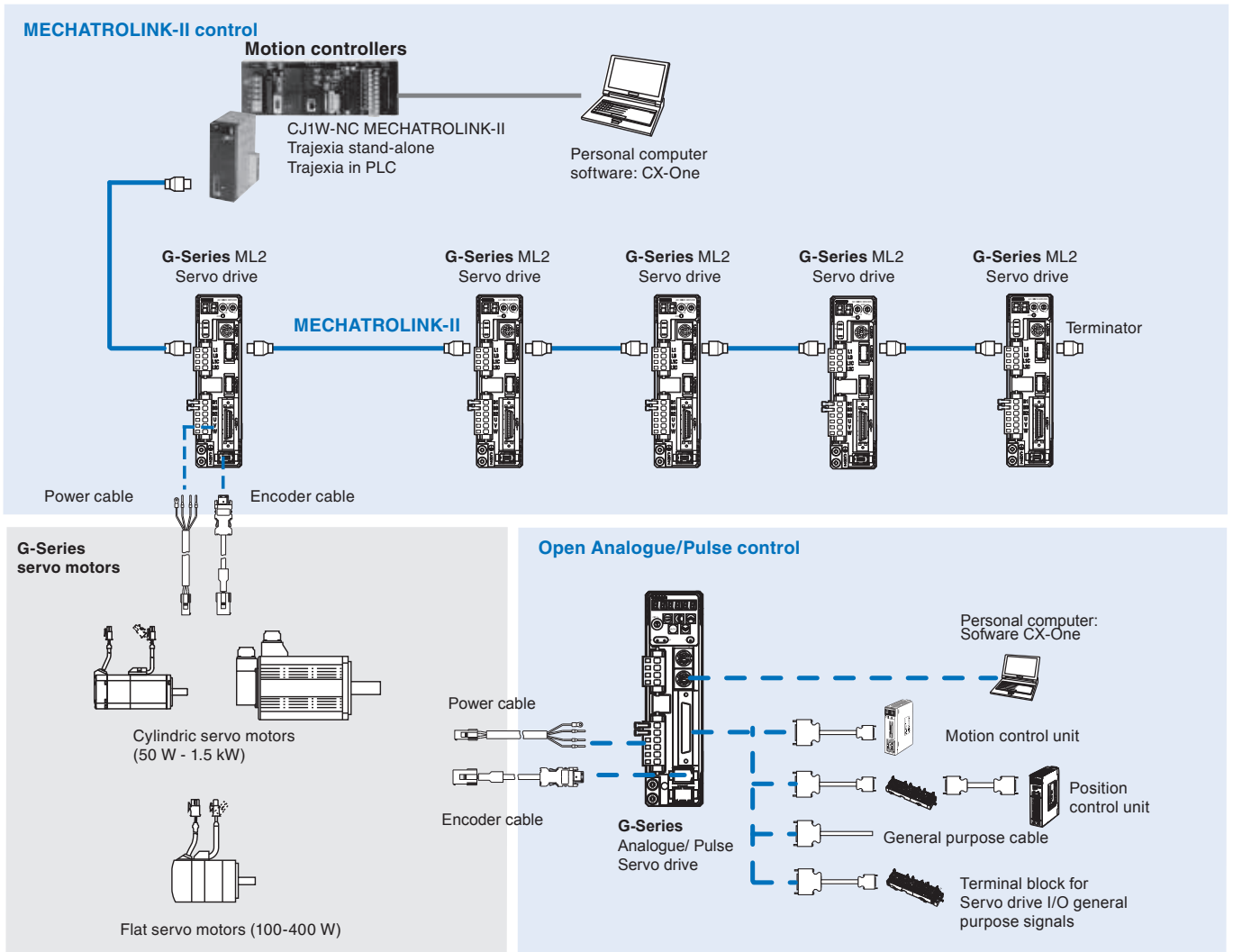

Servo motor supported

Servo motor							G-Series servo drive		
Family	Capacity	Voltage	Speed	Rated torque	Capacity	Model	MECHATROLINK-II	Analog/ Pulse	
Cylindric	50 - 750 W	230 V	3000 min ⁻¹	0.16 Nm	50 W	R88M-G05030□-□S2	R88D-GN01H-ML2	R88D-GT01H	
				0.32 Nm	100 W	R88M-G10030□-□S2	R88D-GN01H-ML2	R88D-GT01H	
				0.64 Nm	200 W	R88M-G20030□-□S2	R88D-GN02H-ML2	R88D-GT02H	
				1.3 Nm	400 W	R88M-G40030□-□S2	R88D-GN04H-ML2	R88D-GT04H	
				2.4 Nm	750 W	R88M-G75030□-□S2	R88D-GN08H-ML2	R88D-GT08H	
	900 - 1500 W		2000 min ⁻¹	3.18 Nm	1000 W	R88M-G1K030T-□S2	R88D-GN15H-ML2	R88D-GT15H	
				4.77 Nm	1500 W	R88M-G1K530T-□S2	R88D-GN15H-ML2	R88D-GT15H	
				4.8 Nm	1000 W	R88M-G1K020T-□S2	R88D-GN10H-ML2	R88D-GT10H	
				7.15 Nm	1500 W	R88M-G1K520T-□S2	R88D-GN15H-ML2	R88D-GT15H	
				8.62 Nm	900 W	R88M-G90010T-□S2	R88D-GN15H-ML2	R88D-GT15H	
Flat	100-400 W	3000 min ⁻¹	0.32 Nm	100 W	R88M-GP10030□-□S2	R88D-GN01H-ML2	R88D-GT01H		
			0.64 Nm	200 W	R88M-GP20030□-□S2	R88D-GN02H-ML2	R88D-GT02H		
			1.3 Nm	400 W	R88M-GP40030□-□S2	R88D-GN04H-ML2	R88D-GT04H		

Type designation

Servo drive

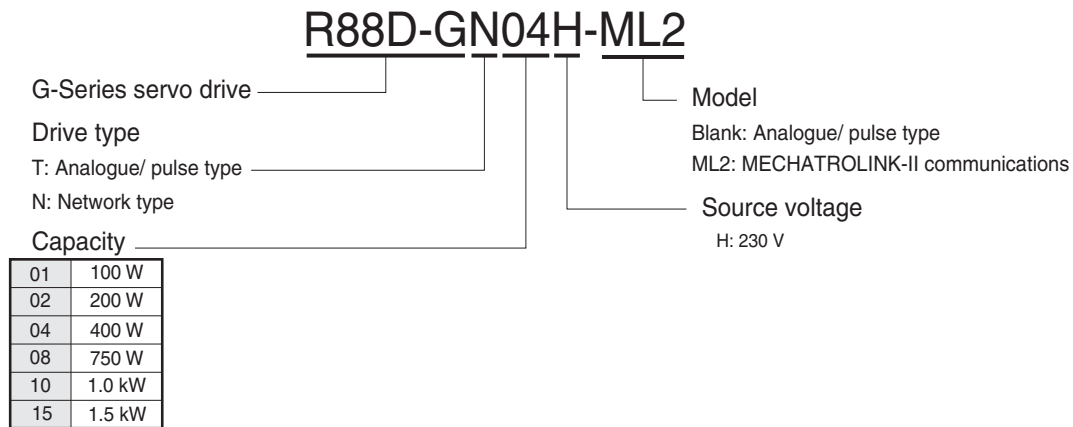

Servo drive specifications

General specifications

Servo drive type		R88D-G□	01H□	02H□	04H□	08H□	10H□	15H□	
Applicable servomotor	R88M-G□	05030□/10030□	20030□	40030□	75030□	G1K020T□	90010T□ / 1K030T□ / 1K5□0T□		
	R88M-GP□	10030□	20030□	40030□	-	-	-		
Max. applicable motor capacity	W	100	200	400	750	1000	1500		
Continuous output current	Arms	1.16	1.6	2.7	4.0	5.9	9.8		
Max. output current	Arms	3.5	5.3	7.1	14.1	21.2	28.3		
Input power	Main circuit	For single-phase, 200 to 240 VAC +10 to -15% (50/60 Hz)				For single-phase/ three-phase, 200 to 240 VAC +10 to -15% (50/60 Hz)			
Supply	Control circuit	For single-phase, 200 to 240 VAC + 10 to -15% (50/60 Hz)							
Control method	IGBT-driven PWM method								
Feedback	Serial encoder (incremental/absolute)								
Conditions	Usage/storage temperature	0 to +55 °C / -20 to 65 °C							
	Usage/storage humidity	90% RH or less (non-condensing)							
	Altitude	1000m or less above sea level							
	Vibration/shock resistance	5.88 m/s ² / 19.6 m/s ²							
Configuration	Base mounted								
Approx. weight	Kg	0.8	1.1	1.5	1.7				

MECHATROLINK-II servo drive specifications

Position/Speed/torque control mode	Performance	Speed variance	Load variance	During 0 to 100% load ±0.01 max. (at rated speed)	
			Voltage variance	0% at ±10% of rated voltage (at rated speed)	
			Temperature variance	0 to 50°C ±0.1% max. (at rated speed)	
		Frequency characteristics		1 kHz	
		Torque control accuracy (reproducibility)		±3% (at 20% to 100% of rated torque)	
		Soft start time setting		0 to 10 s (acceleration time and deceleration time can be set)	
Command Input	MECHATROLINK Communication		MECHATROLINK-II commands (for sequence, motion, data setting/reference, monitor, adjustment and other commands)		
	I/O signal		Sequence input signal		
		Sequence output signal		Emergency stop, 3 external latch signals, forward/reverse torque limit, forward/reverse run prohibit, origin proximity, 3 general-purpose inputs	
				It is possible to output three types of signals: positioning completed, speed coincidence, rotation speed detection, servo ready, current limit, speed limit, brake release and warning signal	
Integrated functions	Communications	RS-232 communications	Interface	Personal computer	
			Transmission rate	From 2400 to 57600 bps	
			Functions	Parameter setting, status display, alarm display (monitor, clear, history), servo drive data tracing function, test run/autotuning operations, real time trace, absolute encoder setting, default values function	
		MECHATROLINK communications	Communications protocol	MECHATROLINK-II	
			Transmission rate	10 Mbps	
			Data length	32 bytes	
			Functions	Parameter setting, status display, alarm display (monitor, clear, history), default values function	
		Tuning		Horizontal and vertical axis mode. One parameter rigidity setting. Load inertia detection.	
		Dynamic brake (DB)		Operates when main power OFF, servo alarm, overtravel or servo OFF	
		Regenerative processing		Built-in regeneration resistor in models from 750 W to 1.5 kW. External regeneration resistor optionally.	
		Overtravel (OT) prevention function		Dynamic brake, disables torque or emergency stop torque during POT and NOT operation	
		Emergency stop (STOP)		Emergency stop input	
	Encoder divider function		Optional division pulses possible		
	Electronic gearing		0,01<Numerator/Denominator<100		
	Internal speed setting function		8 internal speeds		
	Protective functions		Overvoltage, undervoltage, overcurrent, overload, regeneration overload, servo drive overheat		
	Analog monitor Output		The actual servomotor speed, command speed, torque and number of accumulated pulses can be measured using an oscilloscope or other device.		
	Panel operator	Display functions		A 2-digit 7-segment LED display shows the servo drive status, alarm codes, parameters, etc.	
		Switches		MECHATROLINK-II communications status LED indicator (COM) Rotary switch for setting the MECHATROLINK-II node address	

Analog/pulse servo drive specifications

Control mode		Position, speed and torque control mode		
Performance	Speed variance	Load variance	During 0 to 100% load ±0.01 max. (at rated speed)	
		Voltage variance	0% at ±10% of rated voltage (at rated speed)	
		Temperature dependence	0 to 50°C ±0.1% max. (at rated speed)	
		Frequency characteristics	1 kHz	
		Torque control accuracy (reproducibility)	±3% (at 20% to 100% of rated torque)	
		Soft start time setting	0 to 10 s (acceleration time and deceleration time can be set)	
Position control	Input signal	Command pulse	Input pulse type	
			Input pulse frequency	
			Electronic gearing	
	Speed/torque control	Input signal	Speed reference voltage	10 VDC at 3000 r/min: set at delivery (the scale can be set by parameters)
			Torque limit	3 VDC at rated torque (torque can be limited separately in positive/negative direction)
			Preset speed control	Preset speed is selectable from 8 internal settings by digital inputs.
		Torque control	Torque reference voltage	3 VDC at rated torque: set at delivery (the scale and polarity can be set by parameters).
			Speed limit	Speed limit can be set by parameter.
I/O signal	Sequence input signal		Forward/reverse run prohibit, deviation counter reset, alarm reset, control mode switch, pulse prohibited, speed selection, gain switch, zero speed designation, origin proximity	
	Sequence output signal		Brake release, servo ready and alarm output. It is possible also to output two types of configurable signals: current limit, rotation speed detection, warning signal, speed coincidence, positioning completed	

Communications	RS-232 communications	Interface	Personal computer	
		Transmission rate	From 2400 to 57600 bps	
	RS-485 communications data	Interface	Communication data interface between servo drives and personal computer.	
		Transmission rate	From 2400 to 57600 bps	
Integrated functions	Functions		Parameter setting, status display, alarm display (monitor, clear, history), servo drive data tracing function, test run/autotuning operations, real time trace, absolute encoder setting, default values function	
	Tuning		Horizontal and vertical axis mode. One parameter rigidity setting. Load inertia detection.	
	Dynamic brake (DB)		Operates when main power OFF, servo alarm, overtravel or servo OFF	
	Regenerative processing		Built-in regeneration resistor in models from 750 W to 1.5 kW. External regeneration resistor optionally.	
	Overtravel (OT) prevention function		Dynamic brake, disables torque or emergency stop torque during POT and NOT operation	
	Emergency stop (STOP)		Emergency stop input	
	Encoder divider function		Optional division pulses possible	
	Protective functions		Overvoltage, undervoltage, overcurrent, overload, regeneration overload, servo drive overheat	
	Analog monitor Output		The actual servomotor speed, command speed, torque and number of accumulated pulses can be measured using an oscilloscope or other device.	
	Panel operator	Display functions	A 6-digit 7-segment LED display shows the servo drive status, alarm codes, parameters, etc.	
		Switches	Unit No. switch for serial communications. Value from 0 to F. To identify which servo drive the computer is accessing in RS232 communications when multiple servo drives.	

Servo drive part names

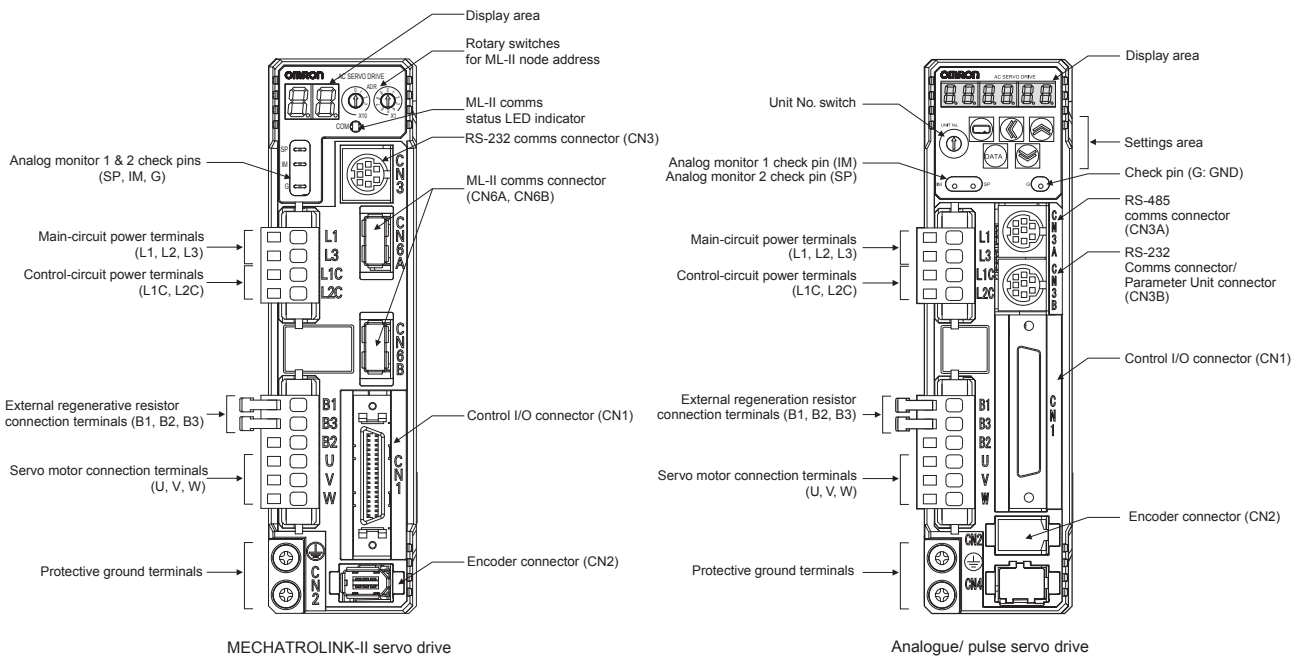

I/O specifications

Main circuit connector (CNA) specifications

Symbol	Name	Function
L1	Main circuits power supply input	AC power input terminals for the main circuit Note: for single-phase connect the power supply input to L1 and L3
L2		
L3		
L1C	Control circuit power supply input	AC power input terminals for the control circuit
L2C		

Servomotor connector (CNB) specifications

Symbol	Name	Function
B1	External regeneration resistor connection terminals	Up to 400 W: If regenerative energy is high, connect an external regeneration resistor between B1 and B2. From 750 W to 1.5kW: Normally B2 and B3 are connected. If regenerative energy is high, remove the short-circuit bar between B2 and B3 and connect an external regeneration resistor between B1 and B2.
B2		
B3		
U	Servo motor connection terminals	Terminals for outputs to the servomotor.
V		
W		
⊕		
⊕	Frame ground	Ground terminal. Ground to 100Ω or less.

I/O signals (CN1) - Input signals (for MECHATROLINK-II servo drives)

Pin No.	Signal name	Function
1	+24VIN	Control power supply input for sequence signals: users must provide the +24 V power supply. Allowable voltage range: 12 to 24 VDC
2	STOP	Emergency Stop Input
3	EXT3	External Latch Signals
4	EXT2	
5	EXT1	
22	IN1	External general-purpose Input 0
6	IN0	External general-purpose Input 1
23	IN2	External general-purpose Input 2
7	PCL	Forward Torque Limit Input
8	NCL	Reverse Torque Limit Input
19	POT	Forward Run Prohibit Input
20	NOT	Reverse Run Prohibit Input
21	DEC	Origin Proximity Input
34	BAT	Battery backup input for absolute encoder
33	BATCOM	Connecting pin for the absolute backup battery. Do not connect when a battery is connected to the servomotor encoder cable.

I/O signals (CN1) - output signals (for MECHATROLINK-II servo drives)

Pin No.	Signal name	Function
15	/ALM	The output turns OFF when an alarm is generated in the Servo drive.
16	ALMCOM	
29	OUTM2	General-purpose output. The function for this output is selected by changing the parameter: INP1 (Positioning completed), VCMP (Speed conformity signal), TGON (Servomotor rotation speed detection), READY (Servo ready), CLIM (Current limit detection), VLIM (Speed limit detection), BKIR (Brake interlock), WARN (Warning signal)
30	OUTM2COM	
31	OUTM3	
32	OUTM3COM	
36	OUTM1	
35	OUTM1COM	

I/O signals (CN1) - Input signals (for analog/pulse servo drives)

Pin No.	Control mode	Signal name	Function	
1	Position	+24 V _{CW}	Reference pulse input for line driver and open collector according to parameter setting.	
3		+C _W		
4		-C _W		
2		+24 V _{CCW}		
5		+C _{CCW}		
6		-C _{CCW}		
44		+C _{WLD}		Reference pulse input for line driver only.
45		-C _{WLD}		
46		+C _{CCWLD}		
47		-C _{CCWLD}		
14	Speed	REF	Speed reference input: ±10 V/rated motor speed (input gain can be modified using a parameter).	
Torque		TREF1	Torque reference input: ±10 V/rated motor torque (input gain can be modified using a parameter).	
		VLIM	Speed limit input: ±10 V/rated motor speed (input gain can be modified using a parameter).	
15	-	AGND1	Analog signal ground	
16	Torque	TREF2	Torque reference input: ±10 V/rated motor torque (input gain can be modified using a parameter).	
Position/Speed		PCL	Forward torque limit input: ±10 V/rated motor torque (input gain can be modified using a parameter).	
	18		NCL	Reverse torque limit input: ±10 V/rated motor torque (input gain can be modified using a parameter).
17	-	AGND	Analog signal ground	

Pin No.	Control mode	Signal name	Function
7	Common	+24 VIN	Control power supply input for sequence signals: users must provide the +24 V power supply (12 to 24 V).
29		RUN	Servo ON: this turn ON the servo.
26	Position	DFSEL	Vibration filter switching
	Speed	PNSSEL	Speed command rotation direction switch
27	Common	VZERO	Zero speed designation
		GSEL	Gain switching
28	Position	TLSEL	Torque limit switch.
		GESEL	Electronic gear switching
30	Speed	VSEL3	Internal speed selection 3
		ECRST	Error counter reset input.
31	Common	VSEL2	Internal speed selection 2
		RESET	Alarm reset input.
32	Position/ Speed/Torque	TVSEL	Control mode switching
			Position ↔ speed } Position ↔ torque } Enables control mode switching Torque ↔ speed }
33	Position	IPG	Pulse prohibition input. Digital input to inhibit the position reference pulse.
		Speed	VSEL1
8	Common	NOT	Reverse run prohibited
9		POT	Forward run prohibited
20	Common	SEN	Sensor ON input. Initial data request signal when using an absolute encoder.
13		SENGND	Sensor ON signal ground.
42	Common	BAT (+)	Backup battery connection terminals when the absolute encoder power is interrupted. Do not connect when an absolute encoder battery cable for backup is used.
43		BATGND (-)	
50		FG	Frame ground

I/O signals (CN1) - Output signals (for analog/pulse servo drives)

Pin No.	Control mode	Signal name	Function
21	Common	+A	Encoder phase A+
22		-A	Encoder phase A-
49		+B	Encoder phase B+
48		-B	Encoder phase B-
23		+Z	Encoder phase Z+
24		-Z	Encoder phase Z-
19		Z	Encoder phase-Z output
25		ZCOM	Encoder phase-Z common
11		BKIR	Brake release signal output
10		BKIRCOM	
35		READY	Servo ready: ON if there is not servo alarm when the control/main circuit power supply is turned ON.
34		READYCOM	
37		/ALM	Servo alarm: turns OFF when an error is detected.
36		ALMCOM	
39	Speed/torque	TGON	Motor rotation speed detection. This output turns ON when the motor rotation speed reaches the speed set in a parameter.
38		TGONCOM	
39	Position	INP	Positioning complete output: turns ON when position error is equal to setting parameter.
38		INPCOM	
-	-	INP2	Position complete output 2
		P-CMD	Position command status
		ZSP	Zero speed
		WARN1	Warning 1
		WARN2	Warning 2
		ALM-ATB	Alarm output
		VCMP	Speed conformity output
		V-CMD	speed command status
		V-LIMIT	Speed limit detection
		T-LIMIT	Torque limit detection
12	Common	OUTM1	General-purpose Output 1
40		OUTM2	General-purpose Output2
41		COM	General-purpose common

Dimensions

Servo drives

R88D-GN01/02H-ML2, R88D-GT01/02H (200 V, 100 to 200 W)

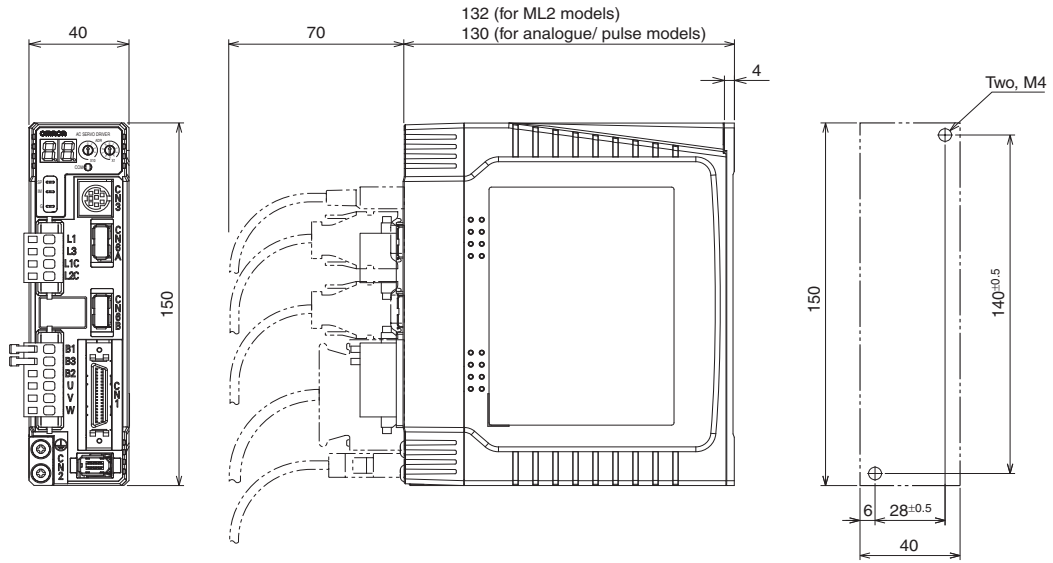

R88D-GN04H-ML2, R88D-GT04H (200 V, 400 W)

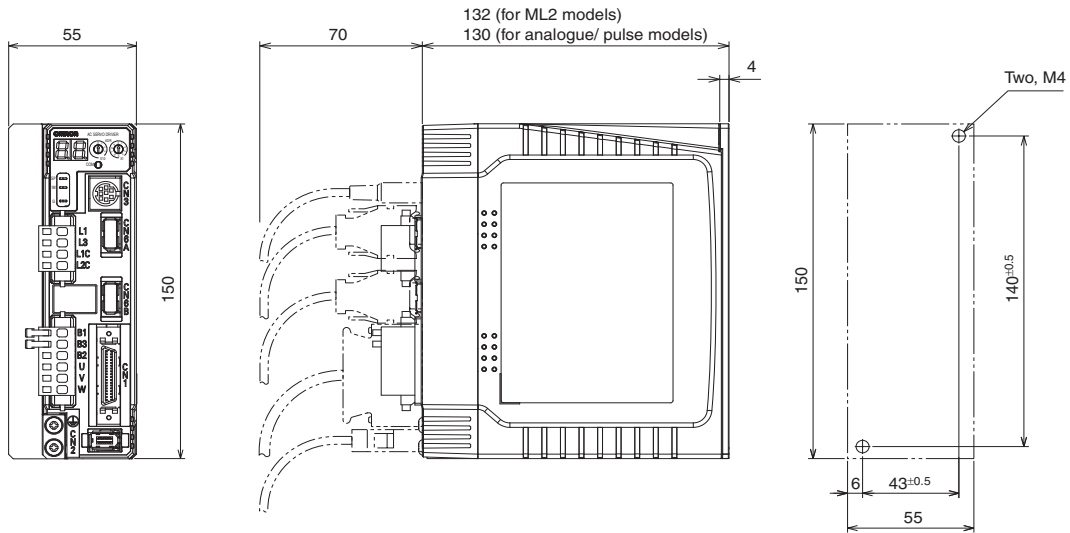

R88D-GN08H-ML2, R88D-GT08H (200 V, 750 W)

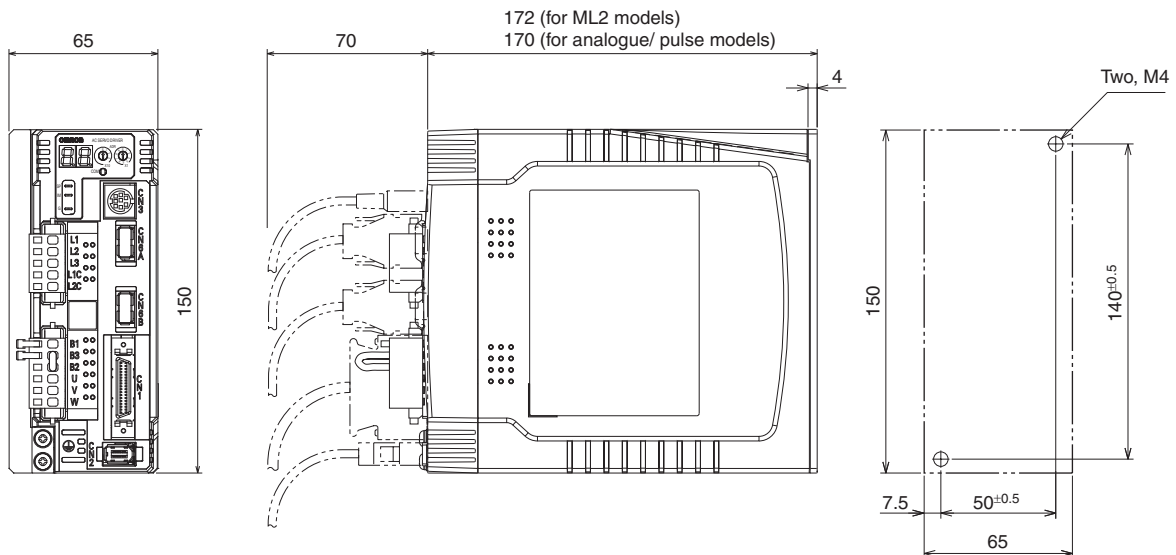

R88D-GN10/15H-ML2, R88D-GT10/15H (200 V, 1 kW to 1,5 kW)

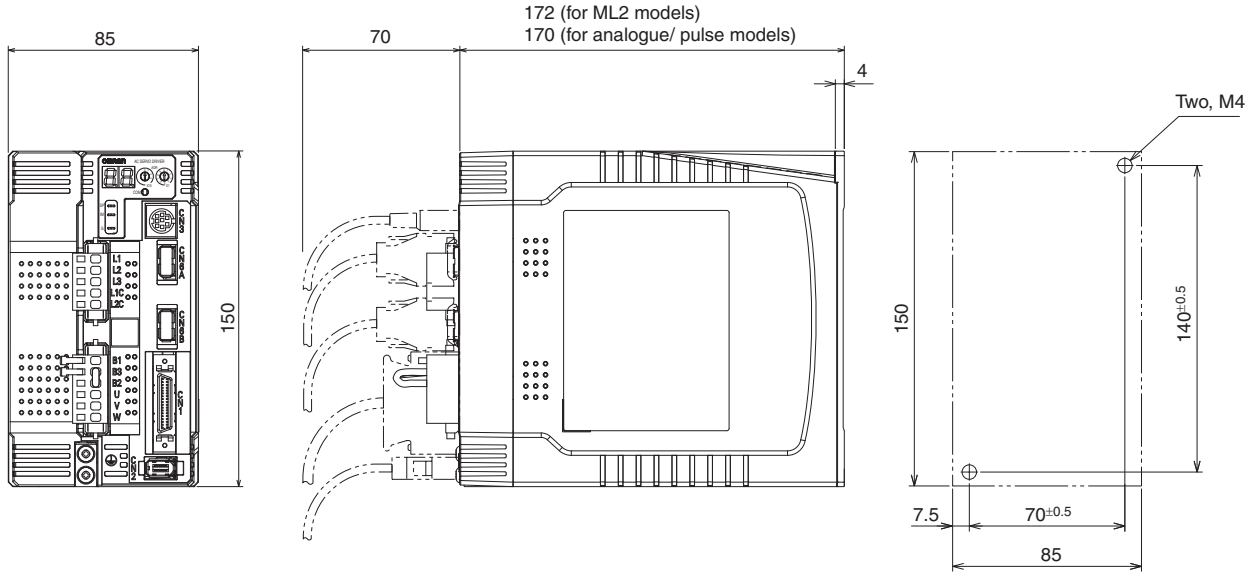

Filters

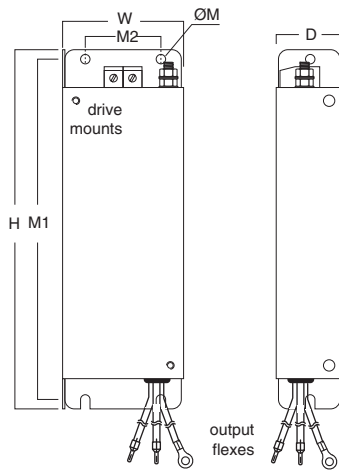

Filter model	Rated current	Leakage current	External dimensions			Mount dimensions		Filter Fixing	Rated voltage
			H	W	D	M1	M2		
R88A-FIK102-RE	2.4 A	3.5 mA	190	42	44	180	20	M4	250 VAC single-phase
R88A-FIK104-RE	4.1 A	3.5 mA	190	57	30	180	30	M4	
R88A-FIK107-RE	6.6 A	3.5 mA	190	64	35	180	40	M4	
R88A-FIK114-RE	14.2 A	3.5 mA	190	86	35	180	60	M4	

Installation

Single-phase, 230 VAC

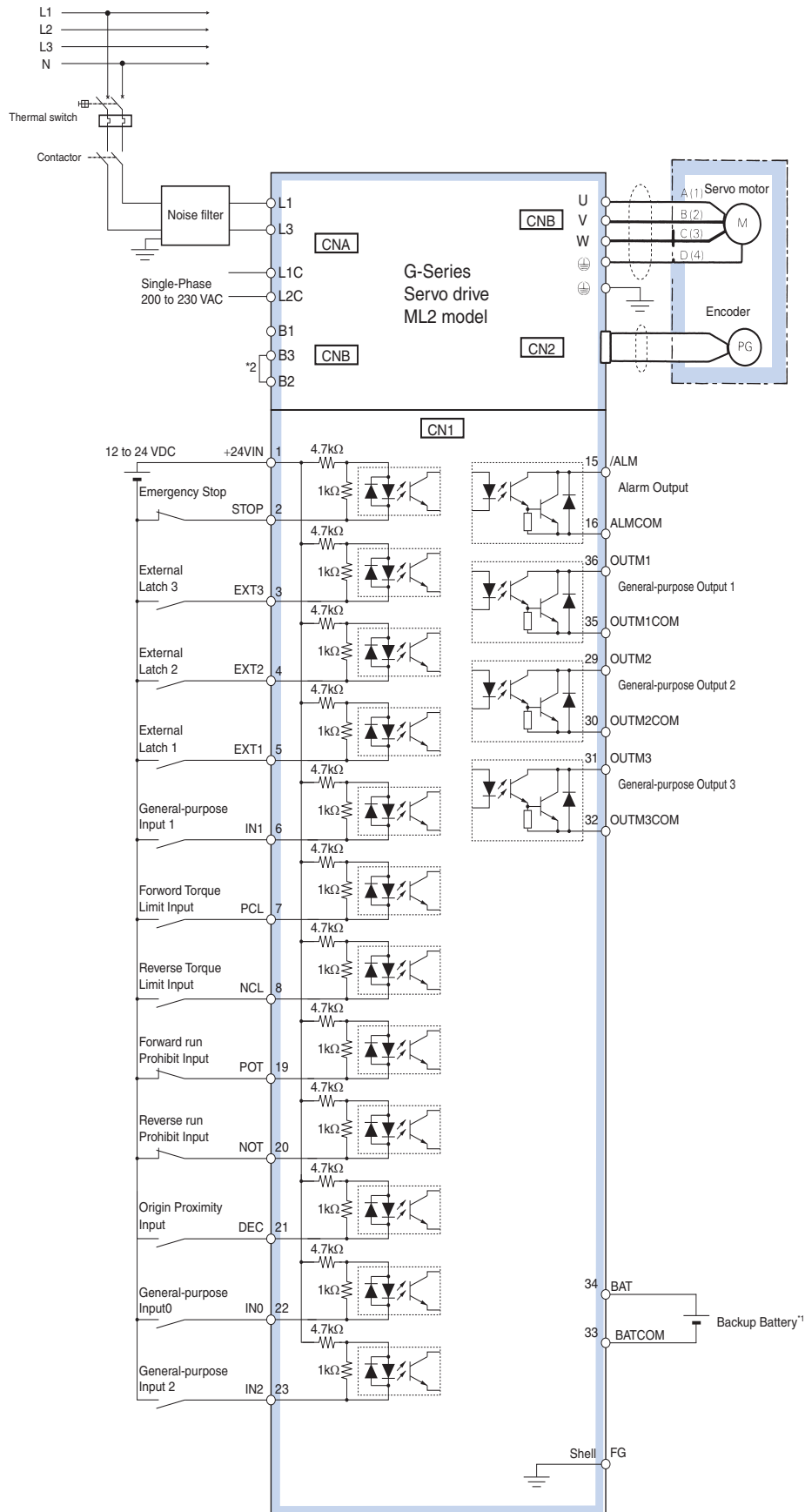

*1 For use only with an absolute encoder. If a backup battery is connected to CN1 I/O connector, an encoder cable with a battery is not required.

*2 For servo drives from 750 W, B2 and B3 are short-circuited. If the internal regenerative resistor is insufficient, remove the wire between B2 and B3 and connect an external resistor between B1 and B2.

AC Servo systems

Single-phase, 230 VAC

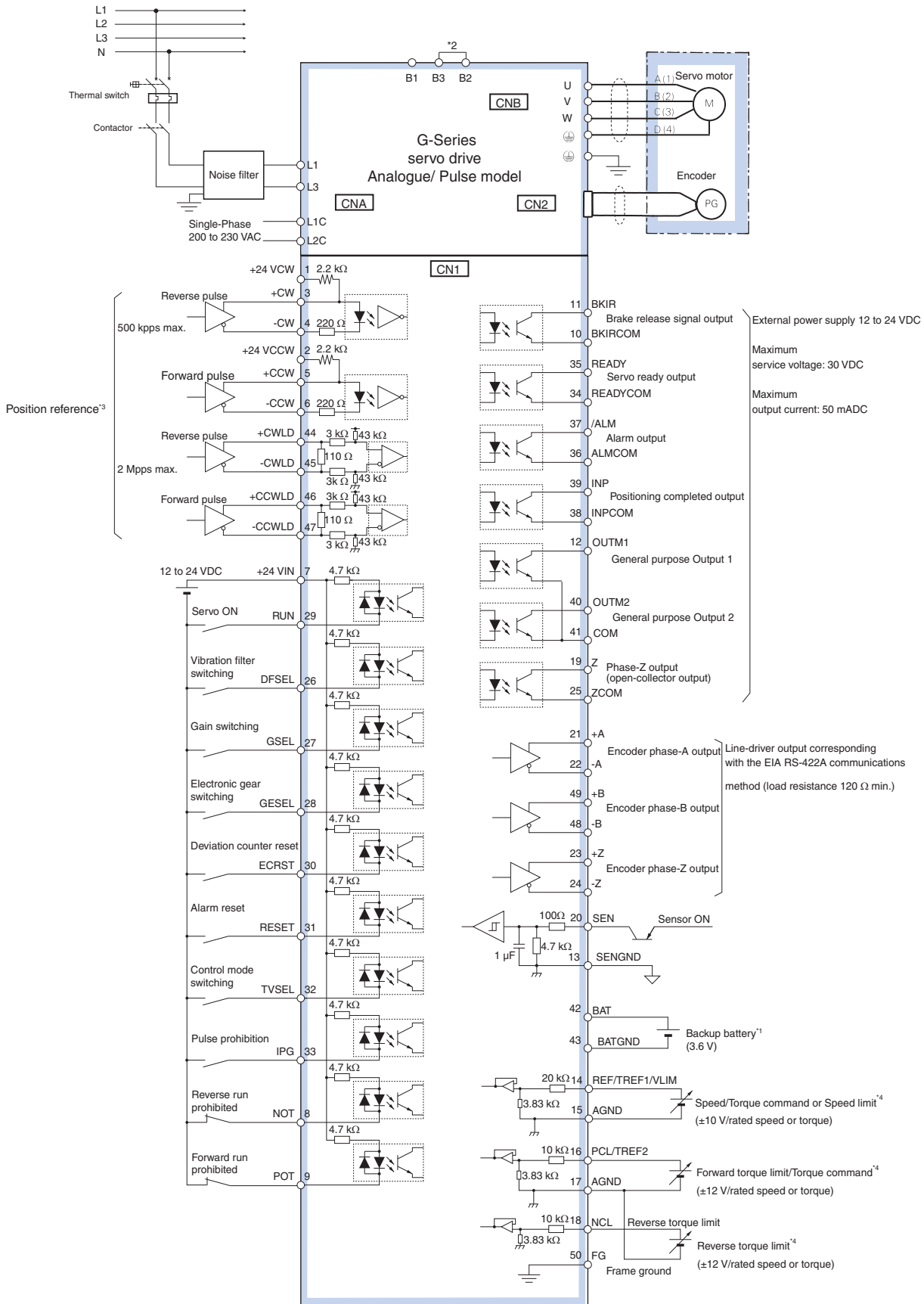

*1 For use only with an absolute encoder. If a backup battery is connected to CN1 I/O connector, an encoder cable with a battery is not required.
 *2 For servo drives from 750 W, B2 and B3 are short-circuited. If the internal regenerative resistor is insufficient, remove the wire between B2 and B3 and connect an external resistor between B1 and B2.
 *3 Only available in Position control mode.
 *4 The input function depends on control mode used (Position, speed or torque control).

Ordering information

G-Series MECHATROLINK-II model reference configuration

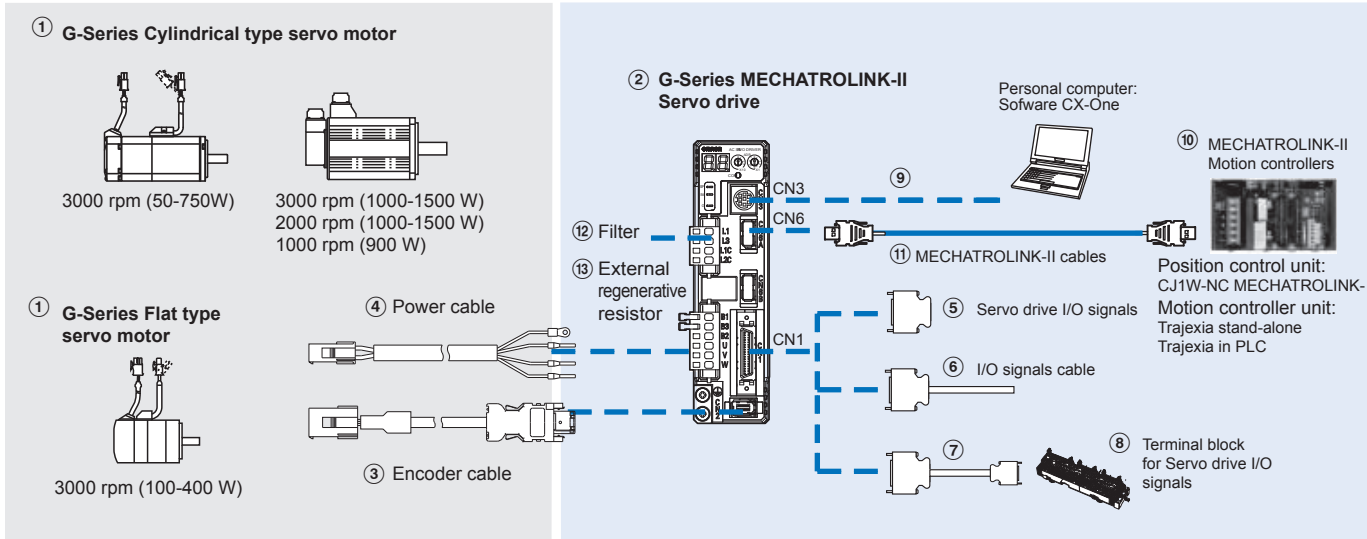

Note: The symbols ①②③④⑤... show the recommended sequence to select the components in a G-Series servo system

Servo motors, power & encoder cables

Note: ①③④ Refer to the G-Series servo motor chapter for servomotor, motor cables or connectors selection

Servo drives

②	Specifications	Servo drive model	① Compatible rotary servo motors	
			Cylindric type	Flat type
1 phase 200 VAC	100 W	R88D-GN01H-ML2	R88M-G05030□ R88M-G10030□	R88M-GP10030□
	200 W	R88D-GN02H-ML2	R88M-G20030□	R88M-GP20030□
	400 W	R88D-GN04H-ML2	R88M-G40030□	R88M-GP40030□
	750 W	R88D-GN08H-ML2	R88M-G75030□	-
	1.0 kW	R88D-GN10H-ML2	R88M-G1K020T□	-
	1.5 kW	R88D-GN15H-ML2	R88M-G90010T□	-
			R88M-G1K030T□	-
R88M-G1K520T□			-	
R88M-G1K530T□			-	

Control cables (for CN1)

Symbol	Name	Connect to	Model	
⑤	I/O connector kit	Servo drive I/O signals	R88A-CNU01C	
⑥	General purpose cable		1 m	R88A-CPGB001S-E
			2 m	R88A-CPGB002S-E
			⑦	Terminal block cable
⑧	Terminal block		2 m	XW2Z-200J-B33
			-	XW2B-20G4
			XW2B-20G5	
			XW2D-20G6	

Computer cable (for CN3)

Symbol	Name	Model
⑨	Computer cable RS232	2 m R88A-CCG002P2

MECHATROLINK-II Motion controllers

Symbol	Name	Model
⑩	Trajexia stand-alone motion controller	TJ2-MC64 (64 axes)
		TJ1-MC16 (16 axes)
		TJ1-MC04 (4 axes)
	Trajexia-PLC motion controller	CJ1W-MCH72 (30 axes)
		CJ1W-MC472 (4 axes)
	Position Controller Unit for CJ1 PLC	CJ1W-NCF71 (16 axes)
		CJ1W-NC471 (4 axes)
		CJ1W-NC271 (2 axes)
	Position Controller Unit for CS1 PLC	CS1W-NCF71 (16 axes)
		CS1W-NC471 (4 axes)
		CS1W-NC271 (2 axes)

MECHATROLINK-II cables (for CN6)

Symbol	Specifications	Length	Model
⑪	MECHATROLINK-II Terminator resistor	-	JEPMC-W6022-E
	MECHATROLINK-II cables	0.5 m	JEPMC-W6003-A5-E
		1 m	JEPMC-W6003-01-E
		3 m	JEPMC-W6003-03-E
		5 m	JEPMC-W6003-05-E
		10 m	JEPMC-W6003-10-E
		20 m	JEPMC-W6003-20-E
		30 m	JEPMC-W6003-30-E

Filters

Symbol	Applicable servodrive	Filter model	Rated current	Leakage current	Rated voltage
⑫	R88D-GN01H□	R88A-FIK102-RE	2.4 A	3.5 mA	250 VAC single-phase
	R88D-GN02H□				
	R88D-GN04H□	R88A-FIK104-RE	4.1 A	3.5 mA	
	R88D-GN08H□				
	R88D-GN10H□	R88A-FIK114-RE	14.2 A	3.5 mA	
	R88D-GN15H□				

External regenerative resistor

Symbol	Regenerative resistor unit model	Specifications
⑬	R88A-RR08050S	50 Ω, 80 W
	R88A-RR080100S	100 Ω, 80 W
	R88A-RR22047S	47 Ω, 220 W
	R88A-RR50020S	20 Ω, 500 W

Computer software

Specifications	Model
Configuration and monitoring software tool for servo drives and inverters. (CX-drive version 1.70 or higher)	CX-drive
Complete OMRON software package including CX-drive. (CX-One version 3.10 or higher)	CX-One

Ordering information

G-Series Analog/pulse model reference configuration

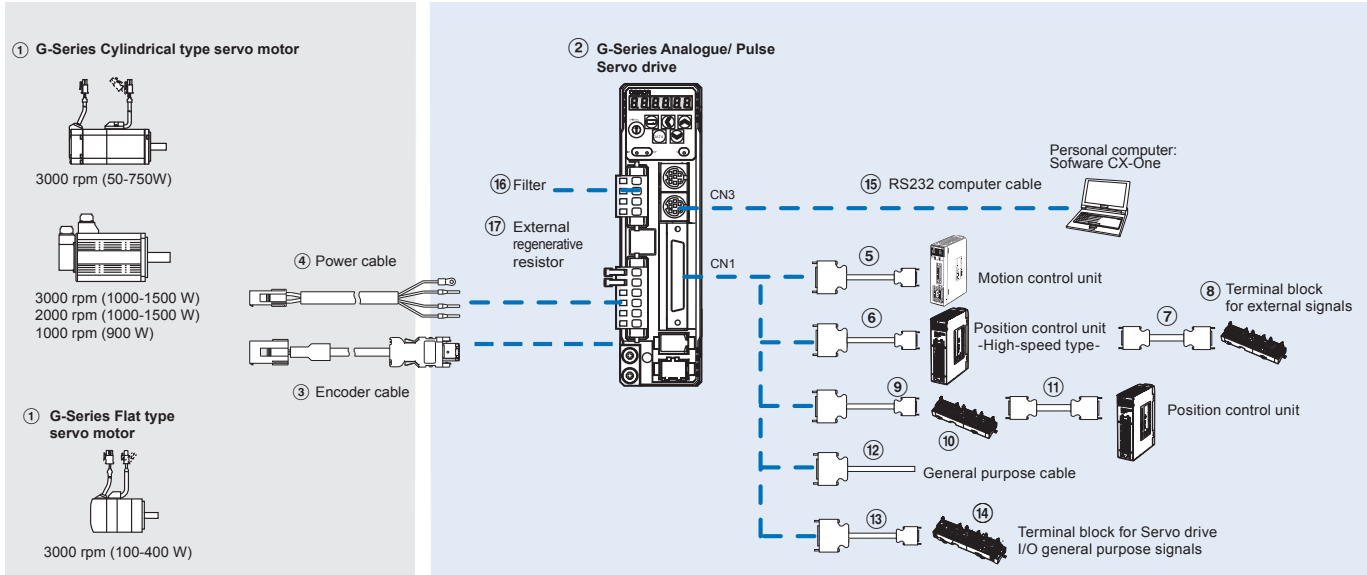

Note: The symbols ①②③④⑤... show the recommended sequence to select the components in a G-Series servo system

Servo motors, power & encoder cables

Note: ①③④ Refer to the G-Series servo motor chapter for servomotor, motor cables or connectors selection

Servo drives

Specifications	Servo drive model	① Compatible rotary servo motors		
		Cylindric type	Flat type	
② 1 phase 200 VAC	100 W	R88D-GT01H	R88M-G05030□ R88M-G10030□	R88M-GP10030□
	200 W	R88D-GT02H	R88M-G20030□	R88M-GP20030□
	400 W	R88D-GT04H	R88M-G40030□	R88M-GP40030□
	750 W	R88D-GT08H	R88M-G75030□	-
	1.0 kW	R88D-GT10H	R88M-G1K020T□	-
	1.5 kW	R88D-GT15H	R88M-G90010T□	-
			R88M-G1K030T□	-
			R88M-G1K520T□ R88M-G1K530T□	- -

Control cables (for CN1)

Symbol	Description	Connect to	Model	
⑤	Control cable (1 axis)	Motion control units CS1W-MC221 CS1W-MC421	1 m	R88A-CPG001M1
			2 m	R88A-CPG002M1
			3 m	R88A-CPG003M1
			5 m	R88A-CPG005M1
			Control cable (2 axis)	Motion control units CS1W-MC221 CS1W-MC421
2 m	R88A-CPG002M2			
3 m	R88A-CPG003M2			
5 m	R88A-CPG005M2			
⑥	Control cable (line-driver output for 1 axis)	Position control units (high-speed type) CJ1W-NC234 CJ1W-NC434	1 m	XW2Z-100J-G9
			5 m	XW2Z-500J-G9
			10 m	XW2Z-10MJ-G9
	Control cable (open-collector output for 1 axis)	Position control units (high-speed type) CJ1W-NC214 CJ1W-NC414	1 m	XW2Z-100J-G13
			3 m	XW2Z-300J-G13
	Control cable (line-driver output for 2 axis)	Position control units (high-speed type) CJ1W-NC234 CJ1W-NC434	1 m	XW2Z-100J-G1
			5 m	XW2Z-500J-G1
			10 m	XW2Z-10MJ-G1
Control cable (open-collector output for 2 axis)	Position control units (high-speed type) CJ1W-NC214 CJ1W-NC414	1 m	XW2Z-100J-G5	
		3 m	XW2Z-300J-G5	

Symbol	Description	Connect to	Model	
⑦	Terminal block cable for external signals (for input common, forward/reverse run prohibited inputs, emergency stop input, origin proximity input and interrupt input)	Position control units (high-speed type) CJ1W-NC234 CJ1W-NC434 CJ1W-NC214 CJ1W-NC414	0.5 m	XW2Z-C50X
			1 m	XW2Z-100X
			2 m	XW2Z-200X
			3 m	XW2Z-300X
			5 m	XW2Z-500X
			10 m	XW2Z-010X
⑧	Terminal block for external signals (M3 screw, pin terminals)		-	XW2B-20G4
	Terminal block for ext. signals (M3.5 screw, fork/round terminals)		-	XW2B-20G5
	Terminal block for ext. signals (M3 screw, fork/round terminals)		-	XW2D-20G6
⑨	Cable from servo relay unit to servo drive	CS1W-NC1□3, CJ1W-NC1□3, C200HW-NC113, CS1W-NC2□3/4□3, CJ1W-NC2□3/4□3, C200HW-NC213/413, CQM1H-PLB21 or CQM1-CPU43	1 m	XW2Z-100J-B25
			2 m	XW2Z-200J-B25
		CJ1M-CPU21/22/23	1 m	XW2Z-100J-B31
			2 m	XW2Z-200J-B31
⑩	Servo relay unit	Position control units CS1W-NC1□3, CJ1W-NC1□3 or C200HW-NC113	-	XW2B-20J6-1B (1 axis)
		Position control units CS1W-NC2□3/4□3, CJ1W-NC2□3/4□3 or C200HW-NC213/413	-	XW2B-40J6-2B (2 axes)
		CQM1H-PLB21 or CQM1-CPU43	-	XW2B-20J6-3B (1 axis)
		CJ1M-CPU21/22/23	-	XW2B-20J6-8A (1 axis) XW2B-40J6-9A (2 axes)
⑪	Position control unit connecting cable	CQM1H-PLB21 or CQM1-CPU43	0.5 m	XW2Z-050J-A3
			1 m	XW2Z-100J-A3
		CS1W-NC113 or C200HW-NC113	0.5 m	XW2Z-050J-A6
			1 m	XW2Z-100J-A6
		CS1W-NC213/413 or C200HW-NC213/413	0.5 m	XW2Z-050J-A7
			1 m	XW2Z-100J-A7
		CS1W-NC133	0.5 m	XW2Z-050J-A10
			1 m	XW2Z-100J-A10
		CS1W-NC233/433	0.5 m	XW2Z-050J-A11
			1 m	XW2Z-100J-A11
		CJ1W-NC113	0.5 m	XW2Z-050J-A14
			1 m	XW2Z-100J-A14
		CJ1W-NC213/413	0.5 m	XW2Z-050J-A15
			1 m	XW2Z-100J-A15
		CJ1W-NC133	0.5 m	XW2Z-050J-A18
			1 m	XW2Z-100J-A18
CJ1W-NC233/433	0.5 m	XW2Z-050J-A19		
	1 m	XW2Z-100J-A19		
CJ1M-CPU21/22/23	0.5 m	XW2Z-050J-A33		
	1 m	XW2Z-100J-A33		
⑫	General purpose cable	For general purpose controllers	1 m	R88A-CPG001S
			2 m	R88A-CPG002S
⑬	Terminal block cable	For general purpose controllers	1 m	XW2Z-100J-B24
			2 m	XW2Z-200J-B24
			-	XW2B-50G4
⑭	Terminal block (M3 screw and for pin terminals)		-	XW2B-50G5
	Terminal block (M3.5 screw and for fork/round terminals)		-	XW2B-50G6
	Terminal block (M3 screw and for fork/round terminals)		-	XW2D-50G6

Computer cable (for CN3)

Symbol	Name	Model
⑮	Computer cable RS232	2 m R88A-CCG002P2

Connectors

Specifications	Model
I/O connector kit, 50 pins (for CN1)	R88A-CNU11C

Filters

Symbol	Applicable servodrive	Filter model	Rated current	Leakage current	Rated voltage
⑯	R88D-GT01H	R88A-FIK102-RE	2.4 A	3.5 mA	250 VAC single-phase
	R88D-GT02H				
	R88D-GT04H	R88A-FIK104-RE	4.1 A	3.5 mA	
	R88D-GT08H	R88A-FIK107-RE	6.6 A	3.5 mA	
	R88D-GT10H	R88A-FIK114-RE	14.2 A	3.5 mA	
	R88D-GT15H				

Computer software

Specifications	Model
Configuration and monitoring software tool for servo drives and inverters. (CX-drive version 1.70 or higher)	CX-drive
Complete OMRON software package including CX-drive. (CX-One version 3.10 or higher)	CX-One

External regenerative resistor

Symbol	Regenerative resistor unit model	Specifications
⑰	R88A-RR08050S	50 Ω, 80 W
	R88A-RR080100S	100 Ω, 80 W
	R88A-RR22047S	47 Ω, 220 W
	R88A-RR50020S	20 Ω, 500 W

ALL DIMENSIONS SHOWN ARE IN MILLIMETERS.
To convert millimeters into inches, multiply by 0.03937. To convert grams into ounces, multiply by 0.03527.