

Wiring device system specific for installations in round and square boxes, characterized by an elegant appearance and classic shapes. The plates, realized in technopolymer in seven colors and in different modularities, from 1 up to 5 gang, are installable indifferently in horizontal or in vertical position. The range, developed around a core of monobloc devices, is available in two colors: white and ivory, in glossy finish. Expandable thanks to the Chorus modular devices.

Category	Support	Material	Technopolymer
Description	For Dahlia plates	For box	Round/Square
Fixing	With clutches/Screws	Glow wire test	650 °C
Thermo-pressure with ball	70 °C	Standard	EN 60669-1

### DIMENSIONAL

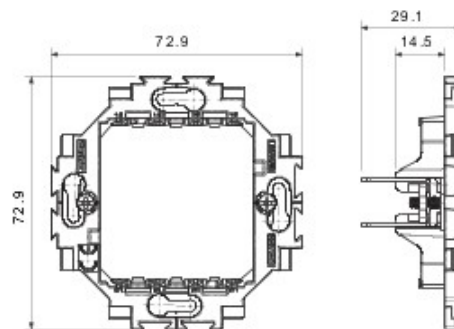

### TECHNICAL SYMBOLOGY



### STANDARDS/APPROVALS

