

High-speed laser ON/OFF and multi-head configuration for ultra-high-speed, high-precision processing



CK3W-GC

Features

- Laser ON/OFF independent of control cycle of the controller
- Synchronization between units for multi-head processing with less head misalignment
- Supports XY2-100 and SL2-100, standard protocols for Galvo scanners
- Galvo mirror control with resolution of up to 20 bits
- Mirror control using up to 3 channels (X, Y, and Z axes)
- CK3W-GC in combination with CK3W-AX and CK3W-ECS for high-speed, on-the-fly laser processing

System Configurations

Basic System Configuration

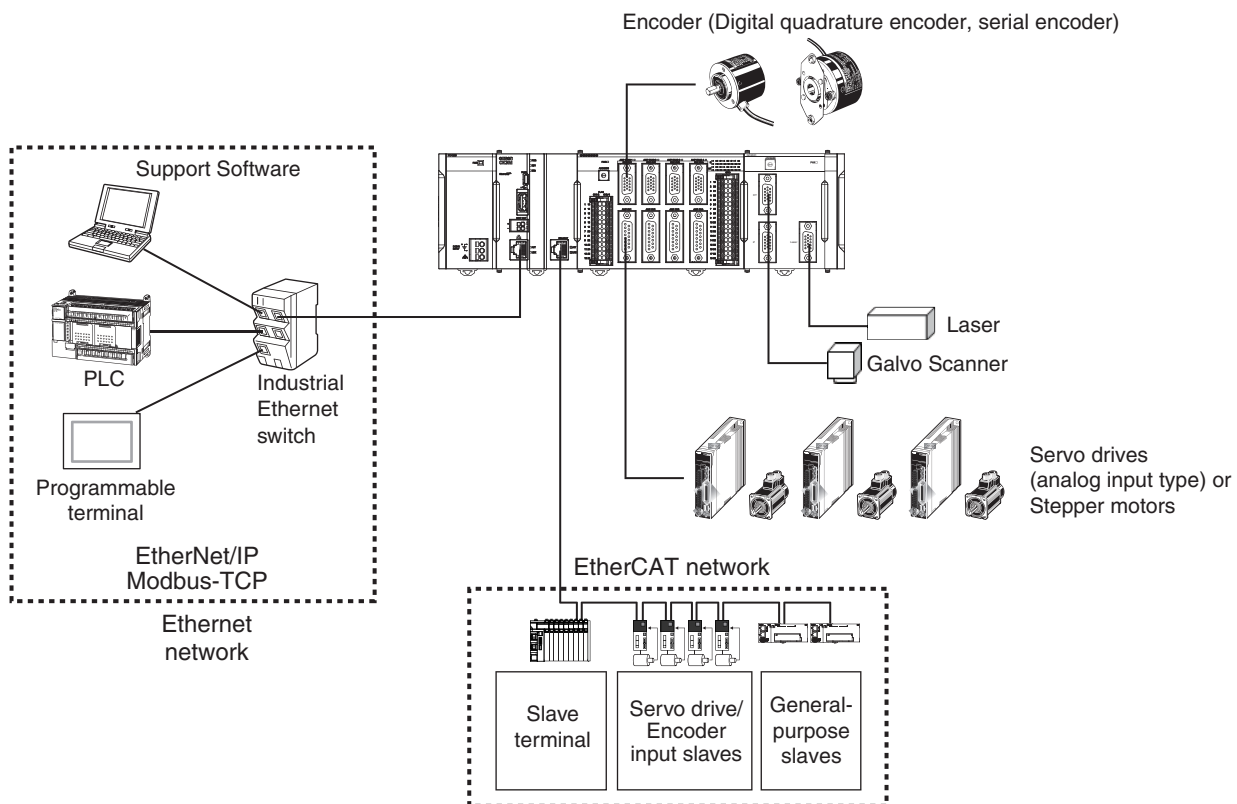

*1. You will need this unit when you use the Galvo Scanner.

CK3W Unit Configuration (CPU Rack/Expansion Rack)

CPU Rack

The CK3W Unit configuration in the CPU Rack consists of a Power Supply Unit, CPU Unit, CK3W-AX Unit, CK3W-MD Unit, CK3W-AD Unit, CK3W-ECS Unit, CK3W-GC Unit, and End Cover.

Up to four CK3W Units (or up to two CK3W-AX Units) can be connected to the CPU Unit.

Expansion Rack

One Expansion Rack can be connected per CPU Unit.

To connect an Expansion Rack, use the Expansion Master Unit (CK3W-EXM01) and Expansion Slave Unit (CK3W-EXS02).

Up to four CK3W Units (or up to two CK3W-AX Units) can be installed to the Expansion Rack.

Connect the Expansion Master Unit (CK3W-EXM01) adjacent to the right side of the CPU Unit. Connect the Expansion Slave Unit (CK3W-EXS02) adjacent to the right side of the Power Supply Unit.

Unless the Expansion Master Unit (CK3W-EXM01) is connected adjacent to the right side of the CPU Unit, the Sys.Status register CK3WConfigErr becomes "5".

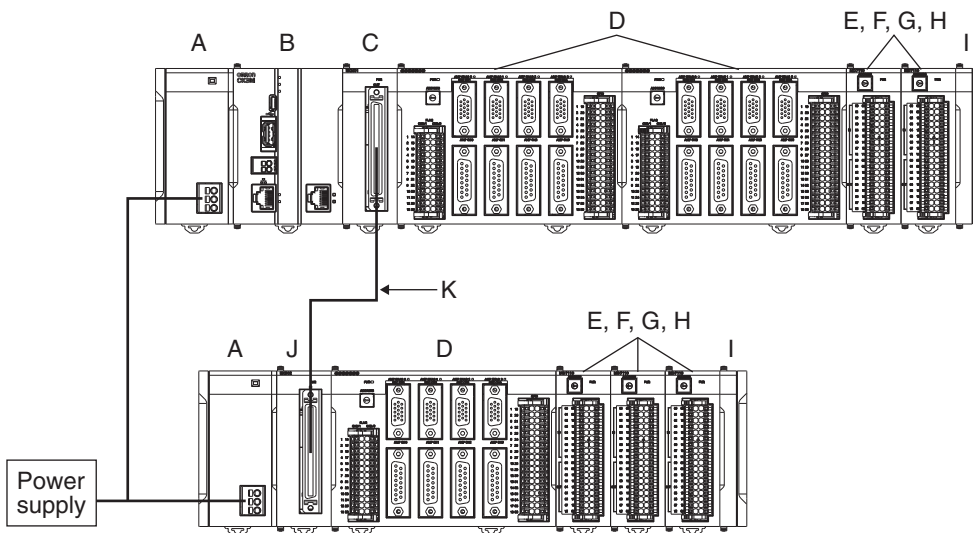

Letter	Configuration	Remarks
A	Power Supply Unit	Input the 24 V power source. Always wire the CPU Rack and Expansion Rack to the same power supply.
B	CK3M-series CPU Unit	This is the Unit at the center of the motion control, which executes the motion program.
C	CK3W-EXM01	Expansion Master Unit. Connect this Unit adjacent to the right side of the CPU Unit in the Expansion Rack.
D	CK3W-AX Unit	Axis Interface Unit. For axis control, connect this to a Servo Drive and encoder.
E	CK3W-MD Unit	Digital I/O Unit. You can add 16 digital inputs and 16 digital outputs.
F	CK3W-AD Unit	Analog Input Unit. You can add 4 or 8 voltage inputs.
G	CK3W-ECS Unit	Encoder Input Unit. You can connect four channels of the serial encoder.
H	CK3W-GC Unit	Laser Interface Unit. You can connect the Galvo Scanner compatible with the interface of XY2-100 or SL2-100.
I	End Cover	Must be connected to the right end of the CPU Rack and Expansion Rack. The CPU Unit and the Expansion Slave Unit are each provided with one End Cover.
J	CK3W-EXS02	Expansion Slave Unit. Use this in the Expansion Rack. Connect this Unit adjacent to the right side of the Power Supply Unit.
K	Expansion cable	Use this cable to connect the Expansion Master Unit and the Expansion Slave Unit. The cable length is 30 cm. Be sure to use the CK3W-CAX003A (30 cm) cable.

EtherCAT Network Configuration

The EtherCAT network configuration consists of a Power Supply Unit, CPU Unit, End Cover, and EtherCAT slaves. Use the built-in EtherCAT port on the CK3M-series CPU Unit to connect EtherCAT slaves.

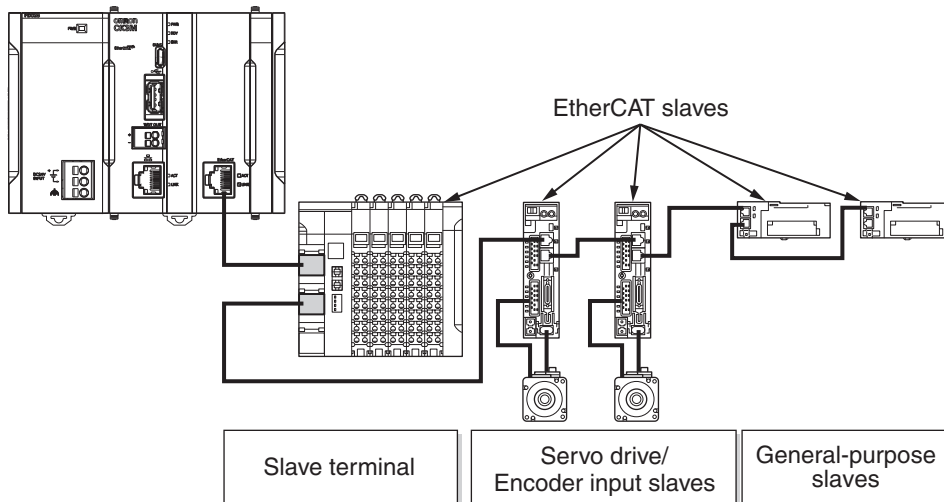

EtherCAT is synchronized with the servo cycle of the CK3M-series CPU Unit. This enables acquisition of the I/O data of slave terminals that are synchronized with the servo cycle.

Refer to the *CK3M-series Programmable Multi-Axis Controller User's Manual Hardware* (Cat.No.O036) for information on using the NX-series EtherCAT Coupler Unit.

Ordering Information

Laser Interface Unit

Product name	Communications method	Laser output	Model
Laser Interface Unit	XY2-100	PWM output	CK3W-GC1100
		PWM output, TCR output	CK3W-GC1200
	SL2-100	PWM output	CK3W-GC2100
		PWM output, TCR output	CK3W-GC2200

Dedicated Cable for Wiring to Galvo Scanner

The dedicated cable for wiring to the Galvo Scanner connector is provided as an option.

The Galvo Scanner connection side has discrete wires. Perform wiring to match the Galvo Scanner specifications.

Type	Length	Model
For Galvo Scanner	3 m	CK3W-CAG03A

You may use a self-made cable.

When you create a self-made cable, use a shielded twisted-pair cable to block the effects of noise.

Dedicated Cable for Wiring to laser connection

The dedicated cable for wiring to the laser connector is provided as an option.

The laser connection side has discrete wires. Perform wiring to match the laser specifications.

Type	Length	Model
For laser connection	3 m	CK3W-CAES03A

You may use a self-made cable.

When you create a self-made cable, use a shielded twisted-pair cable to block the effects of noise.

General Specifications

Item		Specification
Enclosure		Mounted in a panel
Grounding Method		Ground to less than 100 Ω.
Operating Environment	Ambient Operating Temperature	0 to 55°C
	Ambient Operating Humidity	10% to 95% (with no condensation or icing)
	Atmosphere	Must be free of corrosive gases.
	Ambient Storage Temperature	-25 to 70°C (with no condensation or icing)
	Vibration Resistance	Conforms to IEC 60068-2-6. 5 to 8.4 Hz with 3.5-mm amplitude, 8.4 to 150 Hz, acceleration of 9.8 m/s ² 100 min each in X, Y, and Z directions (10 sweeps of 10 min each = 100 min total)
	Shock Resistance	Conforms to IEC 60068-2-27. 147 m/s ² , 3 times each in X, Y, and Z directions
Insulation Resistance		20 MΩ min. between isolated circuits (at 100 VDC)
Dielectric Strength		510 VAC between isolated circuits for 1 minute with a leakage current of 5 mA max.
Applicable Standards		cULus, EU: EN 61326, RCM, KC, EAC

Laser Interface Unit Specifications

	Data length *1	16 bits, 18 bits, or 20 bits
	Clock output frequency	2 MHz
	Data refresh period	10 μs
	Maximum transmission distance	10 m
	Isolation method	Not isolated (between internal circuit and XY2-100 circuit)
XY2-100 Interface	Circuit configuration	
	Terminal connection diagram	

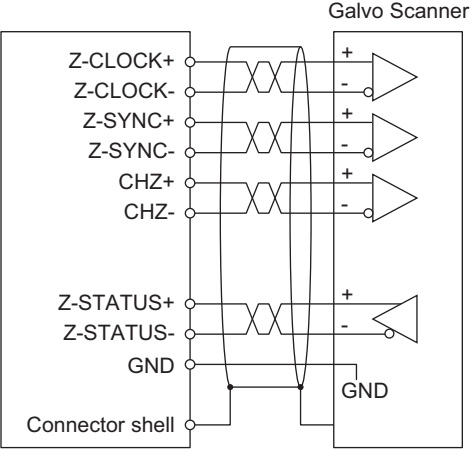
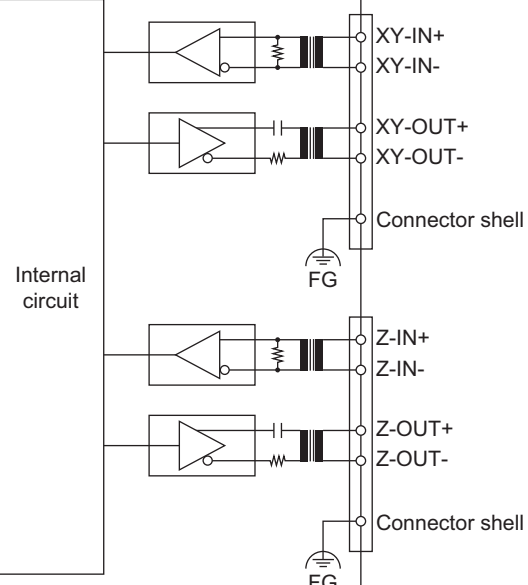
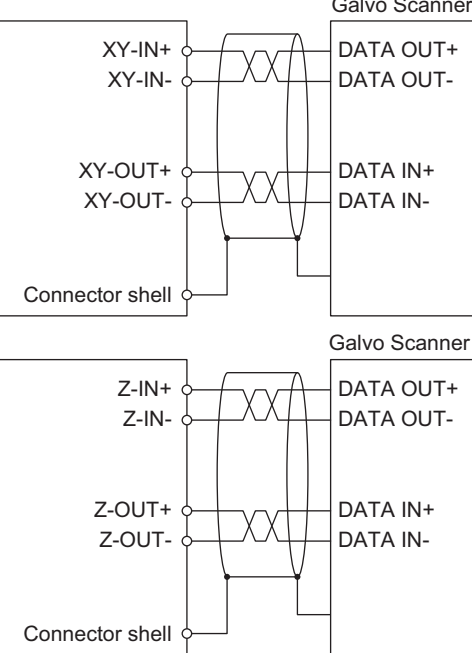
<p>XY2-100 Interface</p>	<p>Terminal connection diagram</p>	
<p>SL2-100 Interface</p>	<p>Data length Maximum transmission distance Cable impedance Isolation method</p> <p>Circuit configuration</p>	<p>20 bits 25 m 110 Ω Isolation by pulse transformer (between internal circuit and SL2-100 circuit)</p> 
<p>Terminal connection diagram</p>	<p>Terminal connection diagram</p>	

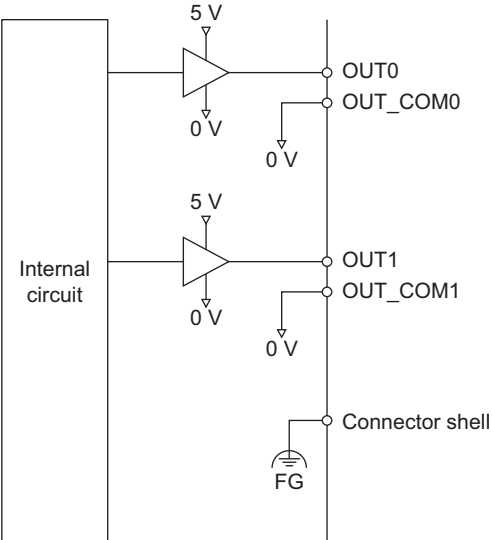
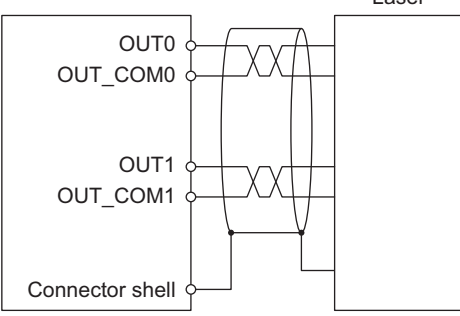
Laser output	Number of points	CK3W-GC□100: 1 point (OUT0: PWM output) CK3W-GC□200: 2 points (OUT0: PWM output, OUT1: TCR output)
	Rated voltage	5 VDC
	Maximum output current	20 mA
	Output voltage (for H output)	3.8 V min.
	Output voltage (for L output)	0.55 V max.
	Response time	100 ns max.
	Maximum transmission distance	25 m
	Isolation method	Not isolated (between internal circuit and laser output circuit)
	Circuit configuration	 <p style="text-align: center;">*2</p>
Terminal connection diagram	 <p style="text-align: center;">*3</p>	
Power consumption	CK3W-GC1□00: 5 VDC 0.6 W max. / 24 VDC 1.9 W max. CK3W-GC2□00: 5 VDC 0.6 W max. / 24 VDC 1.0 W max.	
Dimensions (height × depth × width)	90(H)/80(D)/63.2(W)	
Weight	190 g max.	

*1. It is 16 bits for the XY2-100 Interface in general.
 *2. The CK3W-GC□100 Units do not have the OUT1 circuit.
 *3. The CK3W-GC□100 Units do not need the OUT1 wiring.

Dedicated Cable for Wiring to the Laser Interface Unit

Galvo Scanner Connector Wiring

XY2-100 Interface Wiring

The Unit side connector is a high-density D-sub 15-pin female connector (MIL-C-24308 compliant, lock screw #4-40 UNC).

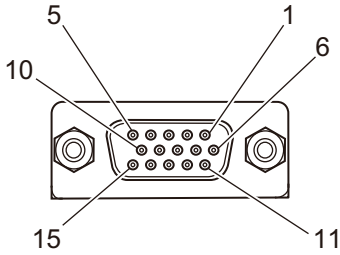

Pin No.	XY		Z	
	Signal	Input/Output	Signal	Input/Output
1	CHX+	Output	CHZ+	Output
2	CHY+	Output	NC	-
3	XY-SYNC+	Output	Z-SYNC+	Output
4	XY-CLOCK+	Output	Z-CLOCK+	Output
5	XY-STATUS+	Input	Z-STATUS+	Input
6	CHX-	Output	CHZ-	Output
7	CHY-	Output	NC	-
8	XY-SYNC-	Output	Z-SYNC-	Output
9	XY-CLOCK-	Output	Z-CLOCK-	Output
10	XY-STATUS-	Input	Z-STATUS-	Input
11	NC	-	NC	-
12	NC	-	NC	-
13	GND	Common	GND	Common
14	GND	Common	GND	Common
15	NC	-	NC	-
Shell	Shield		Shield	

SL2-100 Interface Wiring

The Unit side connector is a high-density D-sub 15-pin female connector (MIL-C-24308 compliant, lock screw #4-40 UNC).

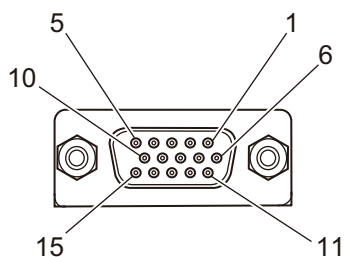

Pin No.	XY		Z	
	Signal	Input/Output	Signal	Input/Output
1	XY-IN+	Input	Z-IN+	Input
2	XY-OUT+	Output	Z-OUT+	Output
3	NC	-	NC	-
4	NC	-	NC	-
5	NC	-	NC	-
6	XY-IN+	Input	Z-IN+	Input
7	XY-OUT+	Output	Z-OUT+	Output
8	NC	-	NC	-
9	NC	-	NC	-
10	NC	-	NC	-
11	NC	-	NC	-
12	NC	-	NC	-
13	NC	-	NC	-
14	NC	-	NC	-
15	NC	-	NC	-
Shell	Shield		Shield	

For Galvo Scanner CK3W-CAG03A

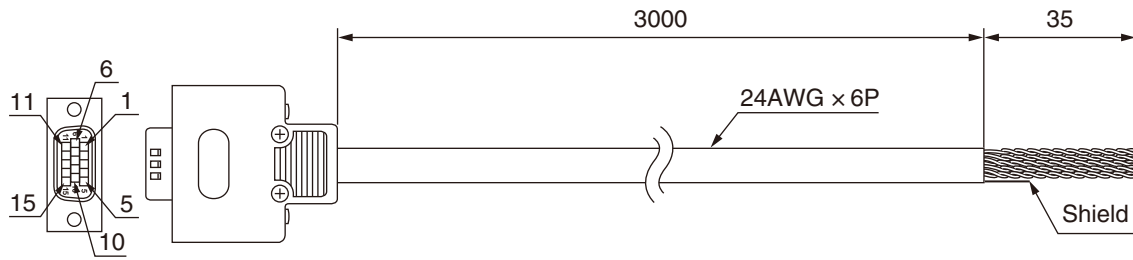

Type	Pin No.	Cable color	Tag *1	Signal			
				XY2-100		SL2-100	
				XY	Z	XY	Z
Pair 1	13	Blue	13	GND	GND	Not wired	Not wired
	14	White	14	GND	GND	Not wired	Not wired
Pair 2	1	Yellow	1	CHX+	CHZ+	XY-IN+	Z-IN+
	6	White	6	CHX-	CHZ-	XY-IN-	Z-IN-
Pair 3	2	Green	2	CHY+	Not wired	XY-OUT+	Z-OUT+
	7	White	7	CHY-	Not wired	XY-OUT-	Z-OUT-
Pair 4	3	Red	3	XY-SYNC+	Z-SYNC+	Not wired	Not wired
	8	White	8	XY-SYNC-	Z-SYNC-	Not wired	Not wired
Pair 5	4	Purple	4	XY-CLOCK+	Z-CLOCK+	Not wired	Not wired
	9	White	9	XY-CLOCK-	Z-CLOCK-	Not wired	Not wired
Pair 6	5	Blue	5	XY-STATUS+	Z-STATUS+	Not wired	Not wired
	10	Brown	10	XY-STATUS-	Z-STATUS-	Not wired	Not wired

*1. For the purpose of identification, each line has the tag that shows a pin No.

Note: The cable shield is connected to the connector shell of the encoder connector.

Laser Connector Wiring

The Unit side connector is a high-density D-sub 15-pin female connector (MIL-C-24308 compliant, lock screw #4-40 UNC).

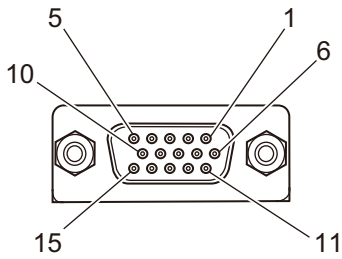

Pin No.	XY	
	Signal	Input/Output
1	NC	-
2	NC	-
3	NC	-
4	OUT0 *1	Output
5	OUT1 *1 *2	Output
6	NC	-
7	NC	-
8	NC	-
9	OUT_COM0 *1	Output
10	OUT_COM1 *1 *2	Output
11	NC	-
12	NC	-
13	NC	-
14	NC	-
15	NC	-
Shell	Shield	

*1. OUT0 is PWM output, and OUT1 is TCR output.
 *2. OUT1 is available with the CK3W-GC□200 Units only.

For laser connection CK3W-CAES03A

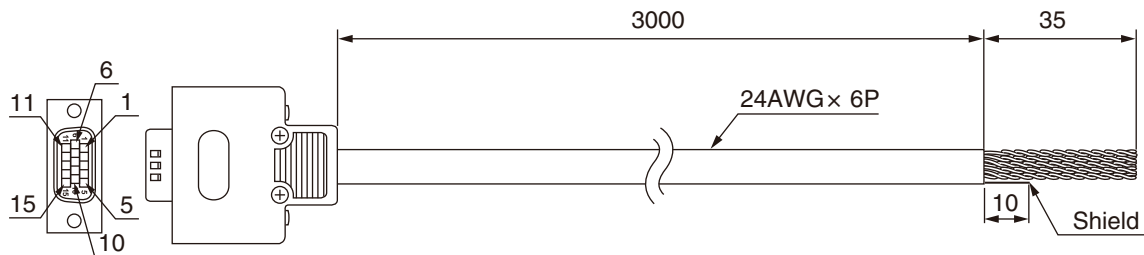

Type	Pin No.	Cable color	Mark	Signal
Pair 1	11	Blue	Black	Not wired
	13	Blue	Red	Not wired
Pair 2	4	Pink	Black	OUT0 *1
	9	Pink	Red	OUT_COM0 *1 *2
Pair 3	5	Green	Black	OUT1 *1
	10	Green	Red	OUT_COM1 *1 *2

*1. OUT0 is PWM output, and OUT1 is TCR output.
 *2. OUT1 is available with the CK3W-GC□200 Units only.

Note: The cable shield is connected to the connector shell of the encoder connector.

Part Names and Functions

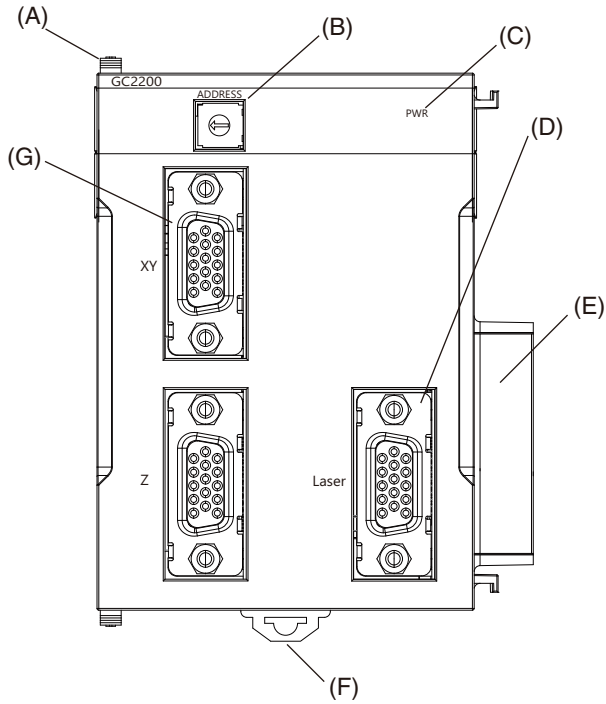

Letter	Name	Function
A	Slider	Holds the Units together.
B	Address switch	Sets the Gate3 Index.
C	Power supply status indicator	Shows the power supply status.
D	Laser connector	Connects the laser.
E	Unit connector	Connector that connects to the Unit.
F	DIN Track mounting hook	Used to mount the Unit to a DIN Track.
G	Galvo Scanner connector	Connects the Galvo Scanner.

The LED indicators show the unit operating status of the Laser Interface Unit.
 The operating statuses corresponding to the colors and statuses of the indicators are shown below.

Indicator name	Color	Status	Description
PWR	Green	ON	Power is supplied.
		OFF	Power is not being supplied.

Dimensions

(Unit: mm)

Laser Interface Unit

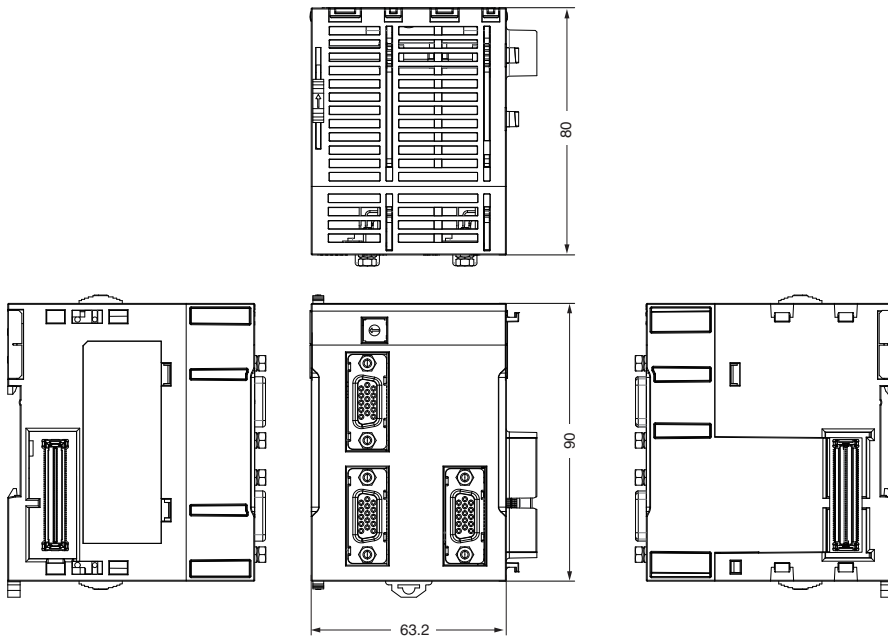

Installation Height

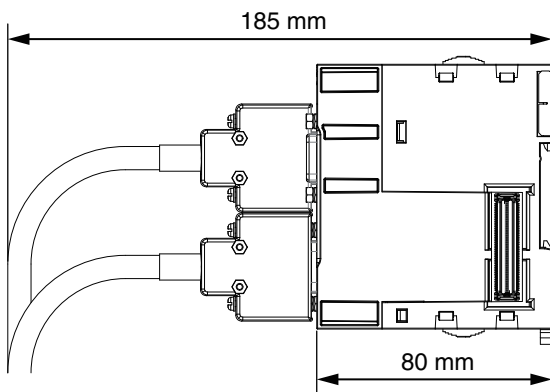

Version Information

This section provides version information that you need to know when connecting a CK3W Unit to a CPU Unit and PowerPMAC IDE. The table below specifies the correspondence between each CK3W Unit and the versions of CPU Unit and Power PMAC IDE.

CK3W Unit	Supported version	
	CPU Unit's PMAC firmware revision	Power PMAC IDE version
CK3W-GC1100 CK3W-GC1200 CK3W-GC2100 CK3W-GC2200	Ver.2.6.1 or later	Ver.4.5 or later

Related Manuals

Manual name	Cat. No.	Application	Description
CK3M-series Programmable Multi-Axis Controller Hardware User's Manual	O036	Learning the basic specifications of the CK3M-series Programmable Multi-Axis Controller, including introductory information, design, installation, and maintenance. Mainly hardware information is provided.	An introduction to the entire CK3M-series system is provided along with the following information. <ul style="list-style-type: none"> • Features and system configuration • Introduction • Part names and functions • General specifications • Installation and wiring • Maintenance and inspection
Power PMAC User's Manual	O014	Learning the features and usage examples of the CK3M-series Programmable Multi-Axis Controller.	The following information is provided on the CK3M-series Programmable Multi-Axis Controller. <ul style="list-style-type: none"> • Basic functions • Setup examples • Programming examples
Power PMAC Software Reference Manual	O015	Learning how to program a CK3M-series Programmable Multi-Axis Controller.	The following information is provided on the CK3M-series Programmable Multi-Axis Controller. <ul style="list-style-type: none"> • Details of commands • Details of data structure
Power PMAC IDE User Manual	O016	Learning how to operate Power PMAC IDE, the integrated development environment of the Controller.	Describes the operating procedures of Power PMAC IDE, and examples of how to start the system.
Power PMAC-NC Quick Start Manual	O017	Briefly understanding the basic usage of Power PMAC-NC.	Describes the Quick setup procedure to run Power PMAC-NC on a desktop PC by showing some examples.
Power PMAC-NC .ini Configuration Manual	O018	Configuring an application for CNC devices by using Power PMAC-NC.	Describes how to set up <i>PowerPmacNC.ini</i> , the setup data file to be loaded when Power PMAC-NC starts.
Power PMAC-NC Software User Manual	O019	Learning about usage and features of Power PMAC-NC, Support Software required to use the Controller for CNC devices.	The following information is provided on Power PMAC-NC. <ul style="list-style-type: none"> • How to use the software • Features included in the software • Features that can be customized
Power PMAC-NC Mill G-Code Manual	O020	Creating programs for CNC devices by using Power PMAC-NC.	Describes the basic G-code set that can be used for Power PMAC-NC, and relevant instructions.

EtherCAT® is a registered trademark and patented technology, licensed by Beckhoff Automation GmbH, Germany.

EtherNet/IP™ is trademarks of ODVA.

Other company names and product names in this document are the trademarks or registered trademarks of their respective companies.

The product photographs and figures that are used in this catalog may vary somewhat from the actual products.

PMAC is an abbreviation for Programmable Multi Axis Controller.

Terms and Conditions Agreement

Read and understand this catalog.

Please read and understand this catalog before purchasing the products. Please consult your OMRON representative if you have any questions or comments.

Warranties.

(a) Exclusive Warranty. Omron's exclusive warranty is that the Products will be free from defects in materials and workmanship for a period of twelve months from the date of sale by Omron (or such other period expressed in writing by Omron). Omron disclaims all other warranties, express or implied.

(b) Limitations. OMRON MAKES NO WARRANTY OR REPRESENTATION, EXPRESS OR IMPLIED, ABOUT NON-INFRINGEMENT, MERCHANTABILITY OR FITNESS FOR A PARTICULAR PURPOSE OF THE PRODUCTS. BUYER ACKNOWLEDGES THAT IT ALONE HAS DETERMINED THAT THE PRODUCTS WILL SUITABLY MEET THE REQUIREMENTS OF THEIR INTENDED USE.

Omron further disclaims all warranties and responsibility of any type for claims or expenses based on infringement by the Products or otherwise of any intellectual property right. (c) Buyer Remedy. Omron's sole obligation hereunder shall be, at Omron's election, to (i) replace (in the form originally shipped with Buyer responsible for labor charges for removal or replacement thereof) the non-complying Product, (ii) repair the non-complying Product, or (iii) repay or credit Buyer an amount equal to the purchase price of the non-complying Product; provided that in no event shall Omron be responsible for warranty, repair, indemnity or any other claims or expenses regarding the Products unless Omron's analysis confirms that the Products were properly handled, stored, installed and maintained and not subject to contamination, abuse, misuse or inappropriate modification. Return of any Products by Buyer must be approved in writing by Omron before shipment. Omron Companies shall not be liable for the suitability or unsuitability or the results from the use of Products in combination with any electrical or electronic components, circuits, system assemblies or any other materials or substances or environments. Any advice, recommendations or information given orally or in writing, are not to be construed as an amendment or addition to the above warranty.

See <http://www.omron.com/global/> or contact your Omron representative for published information.

Limitation on Liability: Etc.

OMRON COMPANIES SHALL NOT BE LIABLE FOR SPECIAL, INDIRECT, INCIDENTAL, OR CONSEQUENTIAL DAMAGES, LOSS OF PROFITS OR PRODUCTION OR COMMERCIAL LOSS IN ANY WAY CONNECTED WITH THE PRODUCTS, WHETHER SUCH CLAIM IS BASED IN CONTRACT, WARRANTY, NEGLIGENCE OR STRICT LIABILITY.

Further, in no event shall liability of Omron Companies exceed the individual price of the Product on which liability is asserted.

Suitability of Use.

Omron Companies shall not be responsible for conformity with any standards, codes or regulations which apply to the combination of the Product in the Buyer's application or use of the Product. At Buyer's request, Omron will provide applicable third party certification documents identifying ratings and limitations of use which apply to the Product. This information by itself is not sufficient for a complete determination of the suitability of the Product in combination with the end product, machine, system, or other application or use. Buyer shall be solely responsible for determining appropriateness of the particular Product with respect to Buyer's application, product or system. Buyer shall take application responsibility in all cases.

NEVER USE THE PRODUCT FOR AN APPLICATION INVOLVING SERIOUS RISK TO LIFE OR PROPERTY OR IN LARGE QUANTITIES WITHOUT ENSURING THAT THE SYSTEM AS A WHOLE HAS BEEN DESIGNED TO ADDRESS THE RISKS, AND THAT THE OMRON PRODUCT(S) IS PROPERLY RATED AND INSTALLED FOR THE INTENDED USE WITHIN THE OVERALL EQUIPMENT OR SYSTEM.

Programmable Products.

Omron Companies shall not be responsible for the user's programming of a programmable Product, or any consequence thereof.

Performance Data.

Data presented in Omron Company websites, catalogs and other materials is provided as a guide for the user in determining suitability and does not constitute a warranty. It may represent the result of Omron's test conditions, and the user must correlate it to actual application requirements. Actual performance is subject to the Omron's Warranty and Limitations of Liability.

Change in Specifications.

Product specifications and accessories may be changed at any time based on improvements and other reasons. It is our practice to change part numbers when published ratings or features are changed, or when significant construction changes are made. However, some specifications of the Product may be changed without any notice. When in doubt, special part numbers may be assigned to fix or establish key specifications for your application. Please consult with your Omron's representative at any time to confirm actual specifications of purchased Product.

Errors and Omissions.

Information presented by Omron Companies has been checked and is believed to be accurate; however, no responsibility is assumed for clerical, typographical or proofreading errors or omissions.

2022.1

In the interest of product improvement, specifications are subject to change without notice.

OMRON Corporation
Industrial Automation Company

<http://www.ia.omron.com/>

(c)Copyright OMRON Corporation 2022 All Right Reserved.