

Lexium 32C

Servo Drive

User Guide

Original instructions

0198441113761.12
12/2021



Legal Information

The Schneider Electric brand and any trademarks of Schneider Electric SE and its subsidiaries referred to in this guide are the property of Schneider Electric SE or its subsidiaries. All other brands may be trademarks of their respective owners.

This guide and its content are protected under applicable copyright laws and furnished for informational use only. No part of this guide may be reproduced or transmitted in any form or by any means (electronic, mechanical, photocopying, recording, or otherwise), for any purpose, without the prior written permission of Schneider Electric.

Schneider Electric does not grant any right or license for commercial use of the guide or its content, except for a non-exclusive and personal license to consult it on an "as is" basis. Schneider Electric products and equipment should be installed, operated, serviced, and maintained only by qualified personnel.

As standards, specifications, and designs change from time to time, information contained in this guide may be subject to change without notice.

To the extent permitted by applicable law, no responsibility or liability is assumed by Schneider Electric and its subsidiaries for any errors or omissions in the informational content of this material or consequences arising out of or resulting from the use of the information contained herein.

As part of a group of responsible, inclusive companies, we are updating our communications that contain non-inclusive terminology. Until we complete this process, however, our content may still contain standardized industry terms that may be deemed inappropriate by our customers.

© 2021 Schneider Electric. All Rights Reserved.

Table of Contents

Safety Information.....	9
Qualification of Personnel	9
Intended Use.....	10
Before You Begin.....	10
Start-up and Test	11
Operation and Adjustments	11
About the Book.....	13
Introduction	19
Device Overview	19
Components and Interfaces.....	20
Nameplate	21
Type Code	22
Technical Data.....	23
Environmental Conditions	23
Dimensions	25
Power Stage Data - General.....	27
Power Stage Data - Drive-Specific	29
Peak Output Currents	34
DC Bus Data	35
24 Vdc Control Supply	36
Signals	37
Output PTO (CN4).....	40
Input PTI (CN5)	41
Capacitor and Braking Resistor	45
Electromagnetic Emission	49
Nonvolatile Memory and Memory Card.....	51
Conditions for UL 508C and CSA.....	52
Engineering.....	53
Electromagnetic Compatibility (EMC)	53
General.....	53
Deactivating the Y Capacitors	56
Cables and Signals.....	58
Cables - General.....	58
Overview of the Required Cables	59
Cable Specifications	60
Logic Type.....	63
Configurable Inputs and Outputs	63
Mains Supply	64
Residual Current Device.....	64
Common DC Bus.....	64
Mains Reactor	65
Rating the Braking Resistor	66
Internal Braking Resistor	66
External Braking Resistor	66
Rating Information	67
Functional Safety.....	71
Basics.....	71

Definitions	74
Function	75
Requirements for Using the Safety-Related Function STO	76
Application Examples STO	78
Installation	80
Mechanical Installation.....	80
Before Mounting	80
Mounting the Drive	82
Electrical Installation	84
Overview of Procedure	84
Connection Overview	85
Connection Grounding Screw	86
Connection Motor Phases and Holding Brake (CN10 and CN11)	87
Connection DC Bus (CN9, DC Bus).....	91
Connection Braking Resistor (CN8, Braking Resistor).....	91
Connection Power Stage Supply (CN1)	94
Connection Motor Encoder (CN3)	97
Connection PTO (CN4, Pulse Train Out).....	98
Connection PTI (CN5, Pulse Train In)	99
Connection 24 Vdc Control Supply and STO (CN2, DC Supply and STO).....	102
Connection Analog Inputs (CN6).....	104
Connection Digital Inputs and Outputs (CN6)	105
Connection PC with Commissioning Software (CN7)	106
Verifying Installation.....	108
Commissioning	109
Overview	109
General.....	109
Preparation	111
Integrated HMI	113
Overview of Integrated HMI	113
Menu Structure	115
Setting Parameters	120
External Graphic Display Terminal	122
Display and Controls	122
Connecting the External Graphic Display Terminal to LXM32	124
Using the External Graphic Display Terminal.....	124
Commissioning Procedure	126
Powering on the Drive for the First Time	126
Setting Limit Values.....	126
Analog Inputs	129
Digital Inputs and Outputs.....	131
Verifying the Signals of the Limit Switches	132
Verifying the Safety Function STO	133
Holding Brake (Option).....	133
Verifying the Direction of Movement	136
Setting Parameters for Encoder	138
Setting the Braking Resistor Parameters	141
Autotuning.....	143
Enhanced Settings for Autotuning	145
Controller Optimization with Step Response	147

Controller Structure	147
Optimization	148
Optimizing the Velocity Controller	149
Verifying and Optimizing the P Gain	154
Optimizing the Position Controller	154
Parameter Management	157
Memory Card	157
Duplicating Existing Parameter Values	159
Resetting the User Parameters	160
Restoring Factory Settings	161
Operation	162
Access Channels	162
Movement Range	164
Size of the Movement Range	164
Scaling	165
General	165
Configuration of Position Scaling	166
Configuration of Velocity Scaling	166
Configuration of Ramp Scaling	167
Digital Signal Inputs and Digital Signal Outputs	169
Parameterization of the Signal Input Functions	169
Parameterization of the Signal Output Functions	176
Parameterization of Software Debouncing	181
PTI and PTO Interface	184
Setting the PTI Interface	184
Setting the PTO Interface	185
Switching Between Control Loop Parameter Sets	188
Overview of the Controller Structure	188
Overview of Position Controller	189
Overview of Velocity Controller	189
Overview of Current Controller	190
Parameterizable Control Loop Parameters	191
Selecting a Control Loop Parameter Set	192
Automatically Switching Between Control Loop Parameter Sets	193
Copying a Control Loop Parameter Set	196
Deactivating the Integral Term	197
Control Loop Parameter Set 1	197
Control Loop Parameter Set 2	199
Operating States and Operating Modes	202
Operating States	202
State Diagram and State Transitions	202
Indication of the Operating State via HMI	205
Indication of the Operating State via Signal Outputs	205
Changing the Operating State via HMI	205
Changing the Operating State via Signal Inputs	206
Operating Modes	208
Starting and Changing an Operating Mode	208
Operating Mode Jog	210
Overview	210
Parameterization	212
Additional Settings	214

Operating Mode Electronic Gear	216
Overview	216
Parameterization	217
Additional Settings	223
Operating Mode Profile Torque	224
Overview	224
Parameterization	225
Additional Settings	229
Operating Mode Profile Velocity	230
Overview	230
Parameterization	231
Additional Settings	233
Functions for Operation	234
Functions for Target Value Processing	234
Motion Profile for the Velocity	234
Jerk Limitation	235
Stopping Movement with Halt	237
Stopping Movement with Quick Stop	238
Inverting the Analog Signal Inputs	240
Limitation of the Velocity via Signal Inputs	240
Limitation of the Current via Signal Inputs	243
Zero Clamp	246
Relative Movement After Capture (RMAC)	246
Backlash Compensation	249
Functions for Monitoring Movements	252
Limit Switches	252
Load-Dependent Position Deviation (Following Error)	253
Load-Dependent Velocity Deviation	255
Motor Standstill and Direction of Movement	256
Position Deviation Window	257
Velocity Deviation Window	258
Velocity Threshold Value	260
Current Threshold Value	261
Functions for Monitoring Internal Device Signals	263
Temperature Monitoring	263
Monitoring Load and Overload (I ² T Monitoring)	264
Commutation Monitoring	265
Monitoring of Mains Phases	266
Ground Monitoring	267
Examples	269
Examples	269
Diagnostics and Troubleshooting	272
Diagnostics via HMI	272
Diagnostics via the Integrated HMI	272
Acknowledging a Motor Change	273
Displaying Error Messages via the HMI	273
Diagnostics via Signal Outputs	275
Indicating the Operating State	275
Indicating Error Messages	275
Error Messages	277

Description of Error Messages	277
Table of Error Messages	278
Parameters	298
Representation of the Parameters.....	298
List of Parameters	300
Accessories and Spare Parts.....	373
Commissioning Tools.....	373
Memory Cards.....	373
Adapter Cable for Encoder Signals LXM05/LXM15 to LXM32	373
Cables for PTO and PTI	373
Motor Cables.....	373
Encoder Cables.....	376
Connectors	377
External Braking Resistors	377
DC Bus Accessories	378
Mains Reactors	378
External Mains Filters	379
Spare Parts Connectors, Fans, Cover Plates	379
Service, Maintenance, and Disposal	380
Maintenance	380
Replacing the Product.....	381
Replacement of the Motor	382
Shipping, Storage, Disposal	382
Glossary	385
Index	389

Safety Information

Important Information

Read these instructions carefully, and look at the equipment to become familiar with the device before trying to install, operate, service, or maintain it. The following special messages may appear throughout this documentation or on the equipment to warn of potential hazards or to call attention to information that clarifies or simplifies a procedure.



The addition of this symbol to a “Danger” or “Warning” safety label indicates that an electrical hazard exists which will result in personal injury if the instructions are not followed.



This is the safety alert symbol. It is used to alert you to potential personal injury hazards. Obey all safety messages that follow this symbol to avoid possible injury or death.

⚠ DANGER
DANGER indicates a hazardous situation which, if not avoided, will result in death or serious injury.
⚠ WARNING
WARNING indicates a hazardous situation which, if not avoided, could result in death or serious injury.
⚠ CAUTION
CAUTION indicates a hazardous situation which, if not avoided, could result in minor or moderate injury.
NOTICE
NOTICE is used to address practices not related to physical injury.

Please Note

Electrical equipment should be installed, operated, serviced, and maintained only by qualified personnel. No responsibility is assumed by Schneider Electric for any consequences arising out of the use of this material.

A qualified person is one who has skills and knowledge related to the construction and operation of electrical equipment and its installation, and has received safety training to recognize and avoid the hazards involved.

Qualification of Personnel

Only appropriately trained persons who are familiar with and understand the contents of this manual and all other pertinent product documentation are authorized to work on and with this product. These persons must have sufficient technical training, knowledge and experience and be able to foresee and detect potential hazards that may be caused by using the product, by modifying the settings and by the mechanical, electrical and electronic equipment of the entire system in which the product is used.

The qualified person must be able to detect possible hazards that may arise from parameterization, modifying parameter values and generally from mechanical, electrical, or electronic equipment.

The qualified person must be familiar with the standards, provisions, and regulations for the prevention of industrial accidents, which they must observe when designing and implementing the system.

Intended Use

The products described or affected by this document are, along with software, accessories and options, servo-drive systems for three-phase servo motors.

The products are intended for industrial use according to the instructions, directions, examples, and safety information contained in the present user guide and other supporting documentation.

The product may only be used in compliance with all applicable safety regulations and directives, the specified requirements and the technical data.

Prior to using the products, you must perform a risk assessment in view of the planned application. Based on the results, the appropriate safety-related measures must be implemented.

Since the products are used as components in an overall machine or process, you must ensure the safety of persons by means of the design of this overall machine or process.

Operate the products only with the specified cables and accessories. Use only genuine accessories and spare parts.

Any use other than the use explicitly permitted as described herein is prohibited and may result in unanticipated hazards.

Before You Begin

Do not use this product on machinery lacking effective point-of-operation guarding. Lack of effective point-of-operation guarding on a machine can result in serious injury to the operator of that machine.

▲ WARNING

UNGUARDED EQUIPMENT

- Do not use this software and related automation equipment on equipment which does not have point-of-operation protection.
- Do not reach into machinery during operation.

Failure to follow these instructions can result in death, serious injury, or equipment damage.

This automation equipment and related software is used to control a variety of industrial processes. The type or model of automation equipment suitable for each application will vary depending on factors such as the control function required, degree of protection required, production methods, unusual conditions, government regulations, etc. In some applications, more than one processor may be required, as when backup redundancy is needed.

Only you, the user, machine builder or system integrator can be aware of all the conditions and factors present during setup, operation, and maintenance of the machine and, therefore, can determine the automation equipment and the related safeties and interlocks which can be properly used. When selecting automation and control equipment and related software for a particular application, you should refer to the applicable local and national standards and regulations. The National

Safety Council's Accident Prevention Manual (nationally recognized in the United States of America) also provides much useful information.

In some applications, such as packaging machinery, additional operator protection such as point-of-operation guarding must be provided. This is necessary if the operator's hands and other parts of the body are free to enter the pinch points or other hazardous areas and serious injury can occur. Software products alone cannot protect an operator from injury. For this reason the software cannot be substituted for or take the place of point-of-operation protection.

Ensure that appropriate safeties and mechanical/electrical interlocks related to point-of-operation protection have been installed and are operational before placing the equipment into service. All interlocks and safeties related to point-of-operation protection must be coordinated with the related automation equipment and software programming.

NOTE: Coordination of safeties and mechanical/electrical interlocks for point-of-operation protection is outside the scope of the Function Block Library, System User Guide, or other implementation referenced in this documentation.

Start-up and Test

Before using electrical control and automation equipment for regular operation after installation, the system should be given a start-up test by qualified personnel to verify correct operation of the equipment. It is important that arrangements for such a check are made and that enough time is allowed to perform complete and satisfactory testing.

▲ WARNING

EQUIPMENT OPERATION HAZARD

- Verify that all installation and set up procedures have been completed.
- Before operational tests are performed, remove all blocks or other temporary holding means used for shipment from all component devices.
- Remove tools, meters, and debris from equipment.

Failure to follow these instructions can result in death, serious injury, or equipment damage.

Follow all start-up tests recommended in the equipment documentation. Store all equipment documentation for future references.

Software testing must be done in both simulated and real environments.

Verify that the completed system is free from all short circuits and temporary grounds that are not installed according to local regulations (according to the National Electrical Code in the U.S.A, for instance). If high-potential voltage testing is necessary, follow recommendations in equipment documentation to prevent accidental equipment damage.

Before energizing equipment:

- Remove tools, meters, and debris from equipment.
- Close the equipment enclosure door.
- Remove all temporary grounds from incoming power lines.
- Perform all start-up tests recommended by the manufacturer.

Operation and Adjustments

The following precautions are from the NEMA Standards Publication ICS 7.1-1995 (English version prevails):

- Regardless of the care exercised in the design and manufacture of equipment or in the selection and ratings of components, there are hazards that can be encountered if such equipment is improperly operated.
- It is sometimes possible to misadjust the equipment and thus produce unsatisfactory or unsafe operation. Always use the manufacturer's instructions as a guide for functional adjustments. Personnel who have access to these adjustments should be familiar with the equipment manufacturer's instructions and the machinery used with the electrical equipment.
- Only those operational adjustments actually required by the operator should be accessible to the operator. Access to other controls should be restricted to prevent unauthorized changes in operating characteristics.

About the Book

Document Scope

This manual describes technical characteristics, installation, commissioning, operation and maintenance of the servo drive Lexium 32C (LXM32C).

Validity Note

This manual is valid for the standard products listed in the type code, see Type Code, page 22.

For product compliance and environmental information (RoHS, REACH, PEP, EOL, etc.), go to www.se.com/ww/en/work/support/green-premium/.

The characteristics that are described in the present document, as well as those described in the documents included in the Related Documents section below, can be found online. To access the information online, go to the Schneider Electric home page www.se.com/ww/en/download/.

The characteristics that are described in the present document should be the same as those characteristics that appear online. In line with our policy of constant improvement, we may revise content over time to improve clarity and accuracy. If you see a difference between the document and online information, use the online information as your reference.

Related Documents

Title of documentation	Reference number
Lexium 32C - Servo Drive - User Guide (this user guide)	0198441113761 (eng)
	0198441113762 (fre)
	0198441113760 (ger)
	0198441113764 (spa)
	0198441113763 (ita)
	0198441113765 (chi)
LXM32 - Common DC Bus - Application Note	MNA01M001EN (eng)
	MNA01M001DE (ger)

Product Related Information

The use and application of the information contained herein require expertise in the design and programming of automated control systems.

Only you, the user, machine builder or integrator, can be aware of all the conditions and factors present during installation and setup, operation, repair and maintenance of the machine or process.

You must also consider any applicable standards and/or regulations with respect to grounding of all equipment. Verify compliance with any safety information, different electrical requirements, and normative standards that apply to your machine or process in the use of this equipment.

Many components of the equipment, including the printed circuit board, operate with mains voltage, or present transformed high currents, and/or high voltages.

The motor itself generates voltage when the motor shaft is rotated.

⚠ DANGER**ELECTRIC SHOCK, EXPLOSION, OR ARC FLASH**

- Disconnect all power from all equipment including connected devices prior to removing any covers or doors, or installing or removing any accessories, hardware, cables, or wires.
- Place a "Do Not Turn On" or equivalent hazard label on all power switches and lock them in the non-energized position.
- Wait 15 minutes to allow the residual energy of the DC bus capacitors to discharge.
- Measure the voltage on the DC bus with a properly rated voltage sensing device and verify that the voltage is less than 42 Vdc.
- Do not assume that the DC bus is voltage-free when the DC bus LED is off.
- Block the motor shaft to prevent rotation prior to performing any type of work on the drive system.
- Do not create a short-circuit across the DC bus terminals or the DC bus capacitors.
- Replace and secure all covers, accessories, hardware, cables, and wires and confirm that a proper ground connection exists before applying power to the unit.
- Use only the specified voltage when operating this equipment and any associated products.

Failure to follow these instructions will result in death or serious injury.

This equipment has been designed to operate outside of any hazardous location. Only install this equipment in zones known to be free of a hazardous atmosphere.

⚠ DANGER**POTENTIAL FOR EXPLOSION**

Install and use this equipment in non-hazardous locations only.

Failure to follow these instructions will result in death or serious injury.

If the power stage is disabled unintentionally, for example as a result of power outage, errors or functions, the motor is no longer decelerated in a controlled way. Overload, errors or incorrect use may cause the holding brake to no longer operate properly and may result in premature wear.

⚠ WARNING**UNINTENDED EQUIPMENT OPERATION**

- Verify that movements without braking effect cannot cause injuries or equipment damage.
- Verify the function of the holding brake at regular intervals.
- Do not use the holding brake as a service brake.
- Do not use the holding brake for safety-related purposes.

Failure to follow these instructions can result in death, serious injury, or equipment damage.

Drive systems may perform unanticipated movements because of incorrect wiring, incorrect settings, incorrect data or other errors.

▲ WARNING

UNINTENDED MOVEMENT OR MACHINE OPERATION

- Carefully install the wiring in accordance with the EMC requirements.
- Do not operate the product with undetermined settings and data.
- Perform comprehensive commissioning tests that include verification of configuration settings and data that determine position and movement.

Failure to follow these instructions can result in death, serious injury, or equipment damage.

▲ WARNING

LOSS OF CONTROL

- The designer of any control scheme must consider the potential failure modes of control paths and, for certain critical control functions, provide a means to achieve a safe state during and after a path failure. Examples of critical control functions are emergency stop and overtravel stop, power outage and restart.
- Separate or redundant control paths must be provided for critical control functions.
- System control paths may include communication links. Consideration must be given to the implications of unanticipated transmission delays or failures of the link.
- Observe all accident prevention regulations and local safety guidelines.¹
- Each implementation of this equipment must be individually and thoroughly tested for proper operation before being placed into service.

Failure to follow these instructions can result in death, serious injury, or equipment damage.

¹ For additional information, refer to NEMA ICS 1.1 (latest edition), "Safety Guidelines for the Application, Installation, and Maintenance of Solid State Control" and to NEMA ICS 7.1 (latest edition), "Safety Standards for Construction and Guide for Selection, Installation and Operation of Adjustable-Speed Drive Systems" or their equivalent governing your particular location.

Machines, controllers, and related equipment are usually integrated into networks. Unauthorized persons and malware may gain access to the machine as well as to other devices on the network/fieldbus of the machine and connected networks via insufficiently secure access to software and networks.

Schneider Electric adheres to industry best practices in the development and implementation of control systems. This includes a "Defense-in-Depth" approach to secure an Industrial Control System. This approach places the controllers behind one or more firewalls to restrict access to authorized personnel and protocols only.

⚠ WARNING

UNAUTHENTICATED ACCESS AND SUBSEQUENT UNAUTHORIZED MACHINE OPERATION

- Evaluate whether your environment or your machines are connected to your critical infrastructure and, if so, take appropriate steps in terms of prevention, based on Defense-in-Depth, before connecting the automation system to any network.
- Limit the number of devices connected to a network to the minimum necessary.
- Isolate your industrial network from other networks inside your company.
- Protect any network against unintended access by using firewalls, VPN, or other, proven security measures.
- Monitor activities within your systems.
- Prevent subject devices from direct access or direct link by unauthorized parties or unauthenticated actions.
- Prepare a recovery plan including backup of your system and process information.

Failure to follow these instructions can result in death, serious injury, or equipment damage.

For more information on organizational measures and rules covering access to infrastructures, refer to ISO/IEC 27000 series, Common Criteria for Information Technology Security Evaluation, ISO/IEC 15408, IEC 62351, ISA/IEC 62443, NIST Cybersecurity Framework, Information Security Forum - Standard of Good Practice for Information Security.

For reasons of Internet security, for those devices that have a native Ethernet connection, TCP/IP forwarding is disabled by default. Therefore, you must manually enable TCP/IP forwarding. However, doing so may expose your network to possible cyberattacks if you do not take additional measures to protect your enterprise. In addition, you may be subject to laws and regulations concerning cybersecurity.

⚠ WARNING

UNAUTHENTICATED ACCESS AND SUBSEQUENT NETWORK INTRUSION

- Observe and respect any and all pertinent national, regional and local cybersecurity and/or personal data laws and regulations when enabling TCP/IP forwarding on an industrial network.
- Isolate your industrial network from other networks inside your company.
- Protect any network against unintended access by using firewalls, VPN, or other, proven security measures.

Failure to follow these instructions can result in death, serious injury, or equipment damage.

Consult the Schneider Electric Cybersecurity Best Practices for additional information.

Firmware

Use the latest firmware version. Visit <https://www.se.com> or contact your Schneider Electric representative for information on firmware updates.

DC Bus Voltage Measurement

The DC bus voltage can exceed 800 Vdc. The DC bus LED is not an indicator of the absence of DC bus voltage.

DANGER

ELECTRIC SHOCK, EXPLOSION OR ARC FLASH

- Disconnect the voltage supply to all connections.
- Wait 15 minutes to allow the DC bus capacitors to discharge.
- Use a properly rated voltage-sensing device for measuring (greater than 800 Vdc).
- Measure the DC bus voltage between the DC bus terminals (PA/+ and PC/-) to verify that the voltage is less than 42 Vdc.
- Contact your local Schneider Electric representative if the DC bus capacitors do not discharge to less than 42 Vdc within a period of 15 minutes.
- Do not operate the product if the DC bus capacitors do not discharge properly.
- Do not attempt to repair the product if the DC bus capacitors do not discharge properly.
- Do not assume that the DC bus is voltage-free when the DC bus LED is off.

Failure to follow these instructions will result in death or serious injury.

Terminology Derived from Standards

The technical terms, terminology, symbols and the corresponding descriptions in this manual, or that appear in or on the products themselves, are generally derived from the terms or definitions of international standards.

In the area of functional safety systems, drives and general automation, this may include, but is not limited to, terms such as *safety*, *safety function*, *safe state*, *fault*, *fault reset*, *malfunction*, *failure*, *error*, *error message*, *dangerous*, etc.

Among others, these standards include:

Standard	Description
IEC 61131-2:2007	Programmable controllers, part 2: Equipment requirements and tests.
ISO 13849-1:2015	Safety of machinery: Safety related parts of control systems. General principles for design.
EN 61496-1:2013	Safety of machinery: Electro-sensitive protective equipment. Part 1: General requirements and tests.
ISO 12100:2010	Safety of machinery - General principles for design - Risk assessment and risk reduction
EN 60204-1:2006	Safety of machinery - Electrical equipment of machines - Part 1: General requirements
ISO 14119:2013	Safety of machinery - Interlocking devices associated with guards - Principles for design and selection
ISO 13850:2015	Safety of machinery - Emergency stop - Principles for design
IEC 62061:2015	Safety of machinery - Functional safety of safety-related electrical, electronic, and electronic programmable control systems
IEC 61508-1:2010	Functional safety of electrical/electronic/programmable electronic safety-related systems: General requirements.
IEC 61508-2:2010	Functional safety of electrical/electronic/programmable electronic safety-related systems: Requirements for electrical/electronic/programmable electronic safety-related systems.
IEC 61508-3:2010	Functional safety of electrical/electronic/programmable electronic safety-related systems: Software requirements.
IEC 61784-3:2016	Industrial communication networks - Profiles - Part 3: Functional safety fieldbuses - General rules and profile definitions.
2006/42/EC	Machinery Directive
2014/30/EU	Electromagnetic Compatibility Directive
2014/35/EU	Low Voltage Directive

In addition, terms used in the present document may tangentially be used as they are derived from other standards such as:

Standard	Description
IEC 60034 series	Rotating electrical machines
IEC 61800 series	Adjustable speed electrical power drive systems
IEC 61158 series	Digital data communications for measurement and control – Fieldbus for use in industrial control systems

Finally, the term *zone of operation* may be used in conjunction with the description of specific hazards, and is defined as it is for a *hazard zone* or *danger zone* in the *Machinery Directive (2006/42/EC)* and *ISO 12100:2010*.

NOTE: The aforementioned standards may or may not apply to the specific products cited in the present documentation. For more information concerning the individual standards applicable to the products described herein, see the characteristics tables for those product references.

Introduction

Device Overview

General

The Lexium 32 product family consists of various servo drive models that cover different application areas. Together with Lexium BMH servo motors or Lexium BSH servo motors as well as a comprehensive portfolio of options and accessories, the drives are ideally suited to implement compact, high-performance drive solutions for a wide range of power requirements.

Lexium Servo Drive LXM32C

This product manual describes the LXM32C servo drive.

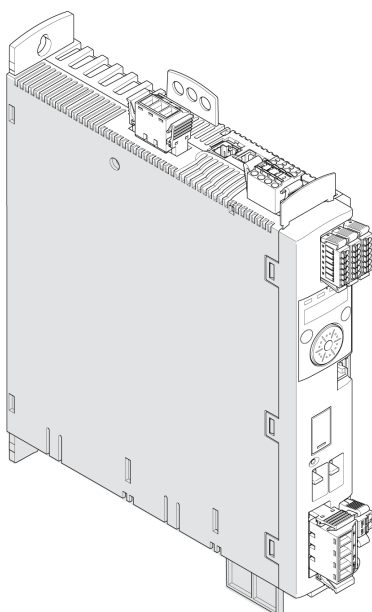

Overview of some of the features of the servo drive:

- Two analog inputs (+/-10V, pulse/direction) for supplying reference values
- The product is commissioned via the integrated HMI, the external graphic display terminal or a PC with commissioning software.
- The safety function "Safe Torque Off" (STO) as per IEC 61800-5-2 is integrated into the drive.
- A memory card slot is provided for backup and copying of parameters and fast device replacement.

Components and Interfaces

Overview

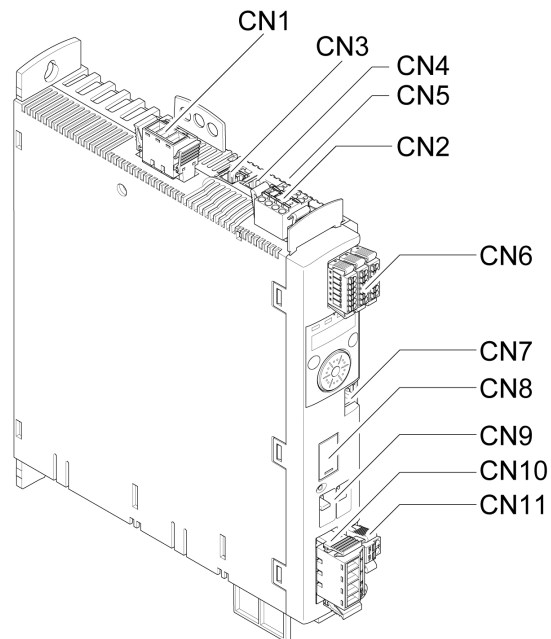

CN1 Power stage supply

CN2 24 Vdc control supply and safety function STO

CN3 Motor encoder (Encoder 1)

CN4 PTO (Pulse Train Out) - ESIM (encoder simulation)

CN5 PTI (Pulse Train In) - P/D, A/B or CW/CCW signals

CN6 2 analog inputs, 6 digital inputs and 5 digital outputs

CN7 Modbus (commissioning interface)

CN8 External braking resistor

CN9 DC bus

CN10 Motor phases

CN11 Motor holding brake

Nameplate

Description

The nameplate contains the following data:

Schneider  Electric				
LXM32.....				
2	Input a.c. 3-phase 50 / 60 Hz	Output		
		continuous	max.	
	380 V - 5.5 A	6 A - 1.8 kW	18 A	
	480 V - 4.5 A	6 A - 1.8 kW	18 A	
Multiple rated equipment, see instructions manual			6	
3	CN1, CN10: Cu AWG10 75°C	5.9 lb.in 0.67 N.m		
	CN8: Cu AWG12 75°C	4.3 lb.in 0.49 N.m		
IP20			7	
RS 03			8	
D.O.M			9	
dd.mm.yy				
000000000000 Made in Indonesia			5	

1 Product type, see Type Code, page 22

2 Power stage supply

3 Cable specifications and tightening torque

4 Certifications (see product catalog)

5 Serial number

6 Output power

7 Degree of protection

8 Hardware version

9 Date of manufacture

Type Code

Description

Item	1	2	3	4	5	6	7	8	9	10	11	12	13	14	15
Type code (example)	L	X	M	3	2	C	D	1	8	M	2

Item	Meaning
1 ... 3	Product family LXM = Lexium
4 ... 5	Product type 32 = AC servo drive for one axis
6	Fieldbus interface C = Compact Drive with analog inputs and Pulse Train
7 ... 9	Peak current U45 = 4.5 A _{rms} U60 = 6 A _{rms} U90 = 9 A _{rms} D12 = 12 A _{rms} D18 = 18 A _{rms} D30 = 30 A _{rms} D72 = 72 A _{rms}
10 ... 11	Power stage supply M2 = Single-phase, 115/200/240 Vac N4 = Three-phase, 208/400/480 Vac
12 ... 15	Customized version S = Customized version

If you have questions concerning the type code, contact your Schneider Electric representative.

Designation Customized Version

In the case of a customized version, position 12 of the type code is an "S". The subsequent number defines the customized version. Example: LXM32.....S123

Contact your local Schneider Electric service representative if you have questions concerning customized versions.

Technical Data

Environmental Conditions

Conditions for Operation

The maximum permissible ambient temperature during operation depends on the clearances between the devices and on the power consumption. Observe the pertinent instructions in the section *Installation*, page 80.

Characteristic	Unit	Value
Ambient temperature (no icing, non-condensing)	°C	0 ... 50
	(°F)	(32 ... 122)

The following relative humidity is permissible during operation:

Characteristic	Unit	Value
Relative humidity (non-condensing)	%	5 ... 95

The installation altitude is defined in terms of altitude above mean sea level.

Characteristic	Unit	Value
Installation altitude above mean sea level without derating.	m	<1000
	(ft)	(<3281)
Altitude above mean sea level when all of the following conditions are met: <ul style="list-style-type: none"> • Maximum ambient temperature 45 °C (113 °F) • Reduction of the continuous power by 1% per 100 m (328 ft) above 1000 m (3281 ft) 	m	1000 ... 2000
	(ft)	(3281 ... 6562)
Altitude above mean sea level when all of the following conditions are met: <ul style="list-style-type: none"> • Maximum ambient temperature 40 °C (104 °F) • Reduction of the continuous power by 1% per 100 m (328 ft) above 1000 m (3281 ft) • Overvoltages of the supply mains limited to overvoltage category II as per IEC 60664-1 • No IT grounding system 	m	2000 ... 3000
	(ft)	(6562 ... 9843)

Conditions for Transportation and Storage

The environment during transportation and storage must be dry and free from dust.

Characteristic	Unit	Value
Temperature	°C	-25 ... 70
	(°F)	(-13 ... 158)

The following relative humidity is permissible during transportation and storage:

Characteristic	Unit	Value
Relative humidity (non-condensing)	%	<95

Installation Site and Connection

For operation, the device must be mounted in a closed and appropriately rated control cabinet secured by a keyed or tooled locking mechanism. The device may only be operated with a permanently installed connection.

Pollution Degree and Degree of Protection

Characteristic	Value
Pollution degree	2
Degree of protection	IP20

Vibration and Shock

Characteristic	Value
Vibration, sinusoidal	Tested as per IEC 60068-2-6 3.5 mm (2 ... 8.4 Hz) 10 m/s ² (8.4 ... 200 Hz)
Shock, semi-sinusoidal	Tested as per IEC 60068-2-27 150 m/s ² (for 11 ms)

Dimensions

Dimensions LXM32•U45, LXM32•U60, LXM32•U90, LXM32•D12, LXM32•D18 and LXM32•D30M2

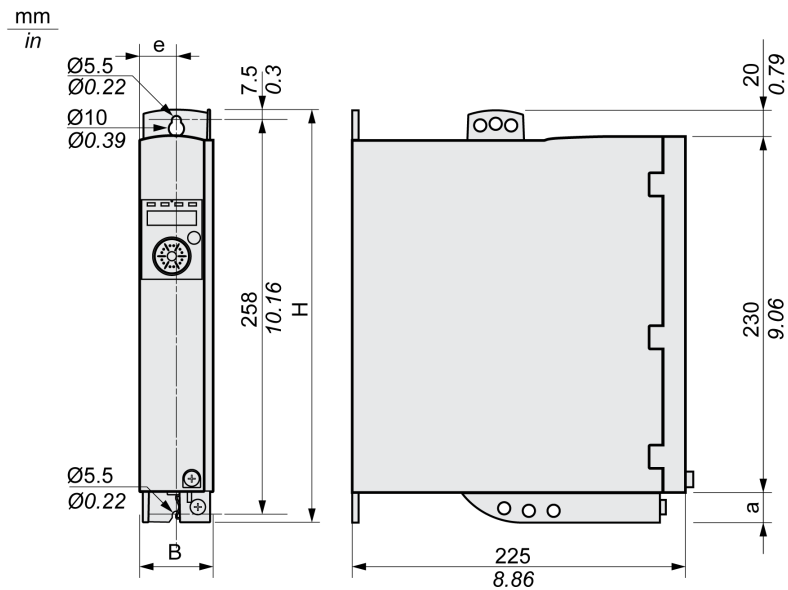

Characteristic	Unit	Value	
		LXM32•U45, LXM32•U60, LXM32•U90	LXM32•D12, LXM32•D18, LXM32•D30M2
B	mm (in)	48 ± 1 (1.99 \pm 0.04)	48 ± 1 (1.99 \pm 0.04)
H	mm (in)	270 (10.63)	270 (10.63)
e	mm (in)	24 (0.94)	24 (0.94)
a	mm (in)	20 (0.79)	20 (0.79)
Type of cooling	-	Convection ⁽¹⁾	Fan 40 mm (1.57 in)
(1) Greater than 1 m/s			

Dimensions LXM32•D30N4 and LXM32•D72

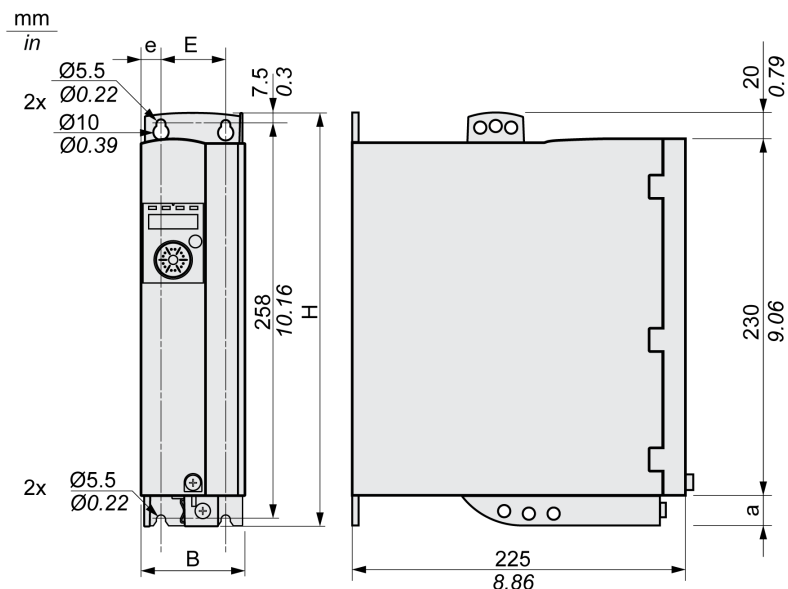

Characteristic	Unit	Value	
		LXM32-D30N4	LXM32-D72
B	mm (in)	68 ±1 (2.68 ±0.04)	108 ±1 (4.25 ±0.04)
H	mm (in)	270 (10.63)	274 (10.79)
e	mm (in)	13 (0.51)	13 (0.51)
E	mm (in)	42 (1.65)	82 (3.23)
a	mm (in)	20 (0.79)	24 (0.94)
Type of cooling	-	Fan 60 mm (2.36 in)	Fan 80 mm (3.15 in)

Mass

Characteristic	Unit	Value					
		LXM32-U45	LXM32-U60, LXM32-U90	LXM32-D12, LXM32-D18- M2	LXM32-D18- N4, LXM32-D30- M2	LXM32-D30- N4	LXM32-D72
Mass	kg (lb)	1.6 (3.53)	1.7 (3.75)	1.8 (3.97)	2.0 (4.41)	2.6 (5.73)	4.7 (10.36)

Power Stage Data - General

Mains Voltage: Range and Tolerance

Characteristic	Unit	Value
115/230 Vac single-phase	Vac	100 -15% ... 120 +10% 200 -15% ... 240 +10%
208/400/480 Vac three-phase ⁽¹⁾	Vac	200 -15% ... 240 +10% 380 -15% ... 480 +10%
Frequency	Hz	50 -5% ... 60 +5%
(1) 208 Vac: With firmware version \geq V01.04 and DOM \geq 10.05.2010		

Characteristic	Unit	Value
Transient overvoltages	-	Overvoltage category III ⁽¹⁾
Rated voltage to ground	Vac	300
(1) Depends on installation altitude, see Environmental Conditions, page 23.		

Type of Grounding

Characteristic	Value
TT grounding system, TN grounding system	Approved
IT grounding system	Depends on hardware version: \geq RS02: Approved ⁽¹⁾ <RS02: Not approved
Mains with corner grounded system	Not approved
(1) Depending on installation altitude, see Environmental Conditions, page 23.	

Leakage Current

Characteristic	Unit	Value
Leakage current (as per IEC 60990, figure 3)	mA	<30 ⁽¹⁾
(1) Measured on mains with grounded neutral point and without external mains filter. Take into account that a 30 mA RCD can already trigger at 15 mA. In addition, there is a high-frequency leakage current which is not considered in the measurement. The response to this depends on the type of residual current device.		

Harmonic Currents and Impedance

The harmonic currents depend on the impedance of the supply mains. This is expressed in terms of the short-circuit current of the supply mains. If the supply mains has a higher short-circuit current than indicated in the Technical Data for the drive, use upstream mains reactors. See Accessories and Spare Parts, page 373 for suitable mains reactors.

Monitoring the Motor Phases for Short-Circuit

The drive provides short-circuit protection according to IEC 60364-4-41:2005/AMD1:-, Clause 411.

Monitoring the Continuous Output Current

The continuous output current is monitored by the drive. If the continuous output current is permanently exceeded, the drive reduces the output current.

PWM Frequency Power Stage

The PWM frequency of the power stage is set to a fixed value.

Characteristic	Unit	Value
PWM frequency power stage	kHz	8

Approved Motors

The following motor families can be connected: BMH, BSH.

When selecting, consider the type and amount of the mains voltage and the motor inductance.

For other motor possibilities, contact your local Schneider Electric representative.

Inductance of Motor

The permissible minimum inductance of the motor to be connected depends on the drive type and the nominal mains voltage. See *Power Stage Data - Drive-Specific*, page 29.

The specified minimum inductance value limits the current ripple of the peak output current. If the inductance value of the connected motor is less than the specified minimum inductance value, this may adversely affect current control and trigger motor phase current monitoring.

Power Stage Data - Drive-Specific

Data for Single-Phase Devices at 115 Vac

Characteristic	Unit	Value			
		LXM32-U45M2	LXM32-U90M2	LXM32-D18M2	LXM32-D30M2
Nominal voltage (single-phase)	Vac	115	115	115	115
Inrush current limitation	A	1.7	3.5	8	16
Maximum fuse to be connected upstream ⁽¹⁾	A	25	25	25	25
Continuous output current	A _{rms}	1.5	3	6	10
Peak output current	A _{rms}	3	6	10	15
Minimum inductance motor (phase/phase)	mH	5.5	3	1.4	0.8
Values without mains reactor⁽²⁾					
Nominal power	kW	0.15	0.3	0.5	0.8
Input current ⁽³⁾	A _{rms}	2.9	5.4	8.5	12.9
THD (total harmonic distortion) ⁽⁴⁾	%	173	159	147	135
Power dissipation ⁽⁵⁾	W	7	15	28	33
Maximum inrush current ⁽⁶⁾	A	111	161	203	231
Time for maximum inrush current	ms	0.8	1.0	1.2	1.4
Values with mains reactor					
Mains reactor	mH	5	2	2	2
Nominal power	kW	0.2	0.4	0.8	0.8
Input current ⁽³⁾	A _{rms}	2.6	5.2	9.9	9.9
THD (total harmonic distortion) ⁽⁴⁾	%	85	90	74	72
Power dissipation ⁽⁵⁾	W	8	16	32	33
Maximum inrush current ⁽⁶⁾	A	22	48	56	61
Time for maximum inrush current	ms	3.3	3.1	3.5	3.7
<p>(1) As per IEC 60269. Circuit breakers with B or C characteristic. See Conditions for UL 508C and CSA, page 52. Lower ratings are permissible. The fuse must be rated in such a way that the fuse does not trip at the specified input current.</p> <p>(2) At a mains impedance corresponding to a short-circuit current of the supply mains of 1 kA.</p> <p>(3) At nominal power and nominal voltage.</p> <p>(4) With reference to the input current.</p> <p>(5) Condition: internal braking resistor not active. Value at nominal current, nominal voltage and nominal power. Value approximately proportional with output current.</p> <p>(6) Extreme case, off/on pulse before the inrush current limitation responds, see next line for maximum time.</p>					

Data for Single-Phase Devices at 230 Vac

Characteristic	Unit	Value			
		LXM32-U45M2	LXM32-U90M2	LXM32-D18M2	LXM32-D30M2
Nominal voltage (single-phase)	Vac	230	230	230	230
Inrush current limitation	A	3.5	6.9	16	33
Maximum fuse to be connected upstream ⁽¹⁾	A	25	25	25	25
Continuous output current	A _{rms}	1.5	3	6	10
Peak output current	A _{rms}	4.5	9	18	30
Minimum inductance motor (phase/phase)	mH	5.5	3	1.4	0.8

Characteristic	Unit	Value			
		LXM32-U45M2	LXM32-U90M2	LXM32-D18M2	LXM32-D30M2
Values without mains reactor⁽²⁾					
Nominal power	kW	0.3	0.5	1.0	1.6
Input current ⁽³⁾	A_{rms}	2.9	4.5	8.4	12.7
THD (total harmonic distortion) ⁽⁴⁾	%	181	166	148	135
Power dissipation ⁽⁵⁾	W	10	18	34	38
Maximum inrush current ⁽⁶⁾	A	142	197	240	270
Time for maximum inrush current	ms	1.1	1.5	1.8	2.1
Values with mains reactor					
Mains reactor	mH	5	2	2	2
Nominal power	kW	0.5	0.9	1.6	2.2
Input current ⁽³⁾	A_{rms}	3.4	6.3	10.6	14.1
THD (total harmonic distortion) ⁽⁴⁾	%	100	107	93	86
Power dissipation ⁽⁵⁾	W	11	20	38	42
Maximum inrush current ⁽⁶⁾	A	42	90	106	116
Time for maximum inrush current	ms	3.5	3.2	3.6	4.0
<p>(1) As per IEC 60269. Circuit breakers with B or C characteristic. See Conditions for UL 508C and CSA, page 52. Lower ratings are permissible. The fuse must be rated in such a way that the fuse does not trip at the specified input current.</p> <p>(2) At a mains impedance corresponding to a short-circuit current of the supply mains of 1 kA.</p> <p>(3) At nominal power and nominal voltage.</p> <p>(4) With reference to the input current.</p> <p>(5) Condition: internal braking resistor not active. Value at nominal current, nominal voltage and nominal power. Value approximately proportional with output current.</p> <p>(6) Extreme case, off/on pulse before the inrush current limitation responds, see next line for maximum time.</p>					

Data for Three-Phase Devices at 208 Vac

Characteristic	Unit	Value				
		LXM32-U60-N4	LXM32-D12-N4	LXM32-D18-N4	LXM32-D30-N4	LXM32-D72-N4
Nominal voltage (three-phase)	Vac	208	208	208	208	208
Inrush current limitation	A	2.2	4.9	10	10	29
Maximum fuse to be connected upstream ⁽¹⁾	A	32	32	32	32	32
Continuous output current	A_{rms}	1.5	3	6	10	24
Peak output current	A_{rms}	6	12	18	30	72
Minimum inductance motor (phase/phase)	mH	8.5	4.5	3	1.7	0.7
Values without mains reactor⁽²⁾						
Nominal power	kW	0.35	0.7	1.2	2.0	5
Input current ⁽³⁾	A_{rms}	1.8	3.6	6.2	9.8	21.9
THD (total harmonic distortion) ⁽⁴⁾	%	132	136	140	128	106
Power dissipation ⁽⁵⁾	W	13	26	48	81	204
Maximum inrush current ⁽⁶⁾	A	60	180	276	341	500
Time for maximum inrush current	ms	0.5	0.7	0.9	1.1	1.5
Values with mains reactor						
Mains reactor	mH	2	2	1	1	1
Nominal power	kW	0.4	0.8	1.5	2.6	6.5

Characteristic	Unit	Value				
		LXM32-U60-N4	LXM32-D12-N4	LXM32-D18-N4	LXM32-D30-N4	LXM32-D72-N4
Input current ⁽³⁾	A _{rms}	1.7	3.1	6.0	9.2	21.1
THD (total harmonic distortion) ⁽⁴⁾	%	97	79	78	59	34
Power dissipation ⁽⁵⁾	W	13	27	51	86	218
Maximum inrush current ⁽⁶⁾	A	19	55	104	126	155
Time for maximum inrush current	ms	1.9	2.6	2.6	3.0	3.6

(1) As per IEC 60269. Circuit breakers with B or C characteristic. See Conditions for UL 508C and CSA, page 52. Lower ratings are permissible. The fuse must be rated in such a way that the fuse does not trip at the specified input current.

(2) At a mains impedance corresponding to a short-circuit current of the supply mains of 5 kA.

(3) At nominal power and nominal voltage.

(4) With reference to the input current.

(5) Condition: internal braking resistor not active. Value at nominal current, nominal voltage and nominal power. Value approximately proportional with output current.

(6) Extreme case, off/on pulse before the inrush current limitation responds, see next line for maximum time.

Data for Three-Phase Devices at 400 Vac

Characteristic	Unit	Value				
		LXM32-U60-N4	LXM32-D12-N4	LXM32-D18-N4	LXM32-D30-N4	LXM32-D72-N4
Nominal voltage (three-phase)	Vac	400	400	400	400	400
Inrush current limitation	A	4.3	9.4	19	19	57
Maximum fuse to be connected upstream ⁽¹⁾	A	32	32	32	32	32
Continuous output current	A _{rms}	1.5	3	6	10	24
Peak output current	A _{rms}	6	12	18	30	72
Minimum inductance motor (phase/phase)	mH	8.5	4.5	3	1.7	0.7
Values without mains reactor⁽²⁾						
Nominal power	kW	0.4	0.9	1.8	3.0	7
Input current ⁽³⁾	A _{rms}	1.4	2.9	5.2	8.3	17.3
THD (total harmonic distortion) ⁽⁴⁾	%	191	177	161	148	126
Power dissipation ⁽⁵⁾	W	17	37	68	115	283
Maximum inrush current ⁽⁶⁾	A	90	131	201	248	359
Time for maximum inrush current	ms	0.5	0.7	0.9	1.1	1.4
Values with mains reactor						
Mains reactor	mH	2	2	1	1	1
Nominal power	kW	0.8	1.6	3.3	5.6	13
Input current ⁽³⁾	A _{rms}	1.8	3.4	6.9	11.1	22.5
THD (total harmonic distortion) ⁽⁴⁾	%	108	90	90	77	45
Power dissipation ⁽⁵⁾	W	19	40	74	125	308
Maximum inrush current ⁽⁶⁾	A	28	36	75	87	112

Characteristic	Unit	Value				
		LXM32•U60-N4	LXM32•D12-N4	LXM32•D18-N4	LXM32•D30-N4	LXM32•D72-N4
Time for maximum inrush current	ms	1.9	2.3	2.3	2.6	3.0
<p>(1) As per IEC 60269. Circuit breakers with B or C characteristic. See Conditions for UL 508C and CSA, page 52. Lower ratings are permissible. The fuse must be rated in such a way that the fuse does not trip at the specified input current.</p> <p>(2) At a mains impedance corresponding to a short-circuit current of the supply mains of 5 kA</p> <p>(3) At nominal power and nominal voltage.</p> <p>(4) With reference to the input current.</p> <p>(5) Condition: internal braking resistor not active. Value at nominal current, nominal voltage and nominal power. Value approximately proportional with output current.</p> <p>(6) Extreme case, off/on pulse before the inrush current limitation responds, see next line for maximum time.</p>						

Data for Three-Phase Devices at 480 Vac

Characteristic	Unit	Value				
		LXM32•U60-N4	LXM32•D12-N4	LXM32•D18-N4	LXM32•D30-N4	LXM32•D72-N4
Nominal voltage (three-phase)	Vac	480	480	480	480	480
Inrush current limitation	A	5.1	11.3	23	23	68
Maximum fuse to be connected upstream ⁽¹⁾	A	32	32	32	32	32
Continuous output current	A _{rms}	1.5	3	6	10	24
Peak output current	A _{rms}	6	12	18	30	72
Minimum inductance motor (phase/phase)	mH	8.5	4.5	3	1.7	0.7
Values without mains reactor⁽²⁾						
Nominal power	kW	0.4	0.9	1.8	3.0	7
Input current ⁽³⁾	A _{rms}	1.2	2.4	4.5	7.0	14.6
THD (total harmonic distortion) ⁽⁴⁾	%	201	182	165	152	129
Power dissipation ⁽⁵⁾	W	20	42	76	129	315
Maximum inrush current ⁽⁶⁾	A	129	188	286	350	504
Time for maximum inrush current	ms	0.6	0.7	1.0	1.2	1.6
Values with mains reactor						
Mains reactor	mH	2	2	1	1	1
Nominal power	kW	0.8	1.6	3.3	5.6	13
Input current ⁽³⁾	A _{rms}	1.6	2.9	6.0	9.6	19.5
THD (total harmonic distortion) ⁽⁴⁾	%	116	98	98	85	55
Power dissipation ⁽⁵⁾	W	21	44	82	137	341
Maximum inrush current ⁽⁶⁾	A	43	57	116	137	177
Time for maximum inrush current	ms	1.9	2.4	2.4	2.7	3.2
<p>(1) As per IEC 60269. Circuit breakers with B or C characteristic. See Conditions for UL 508C and CSA, page 52. Lower ratings are permissible. The fuse must be rated in such a way that the fuse does not trip at the specified input current.</p> <p>(2) At a mains impedance corresponding to a short-circuit current of the supply mains of 5 kA</p> <p>(3) At nominal power and nominal voltage.</p> <p>(4) With reference to the input current.</p> <p>(5) Condition: internal braking resistor not active. Value at nominal current, nominal voltage and nominal power. Value approximately proportional with output current.</p> <p>(6) Extreme case, off/on pulse before the inrush current limitation responds, see next line for maximum time.</p>						

Peak Output Currents

Description

The device can provide the peak output current for a limited period of time. If the peak output current flows when the motor is at a standstill, the higher load on a single semiconductor switch causes the current limitation to become active earlier than when the motor moves.

The period of time for which the peak output current can be provided depends on the hardware version.

Peak output current with hardware version \geq RS03: 5 seconds

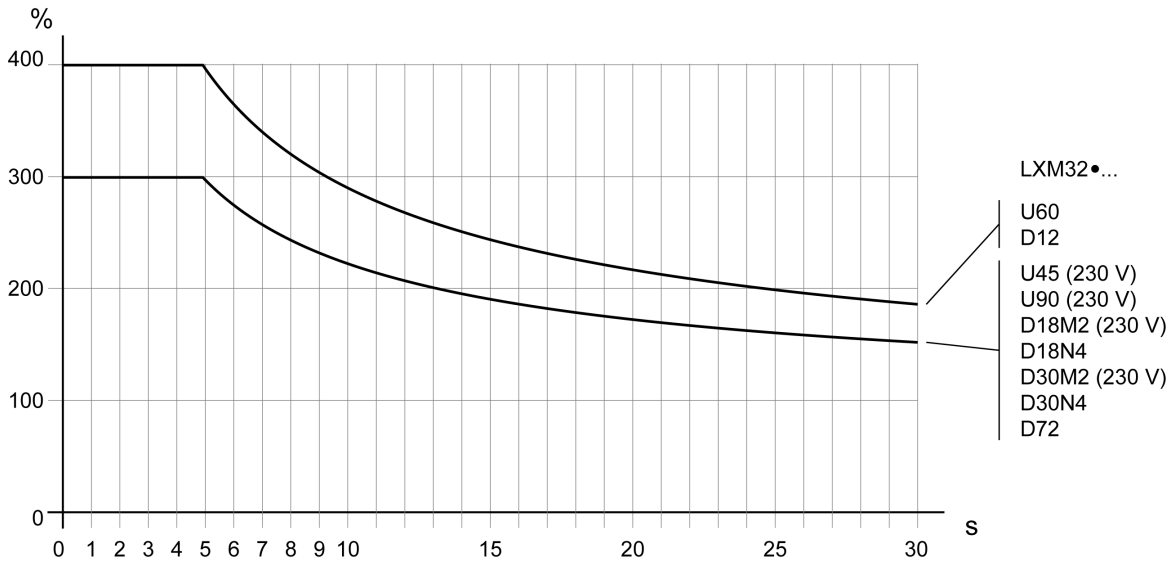

Peak output current with hardware version $<$ RS03: 1 second

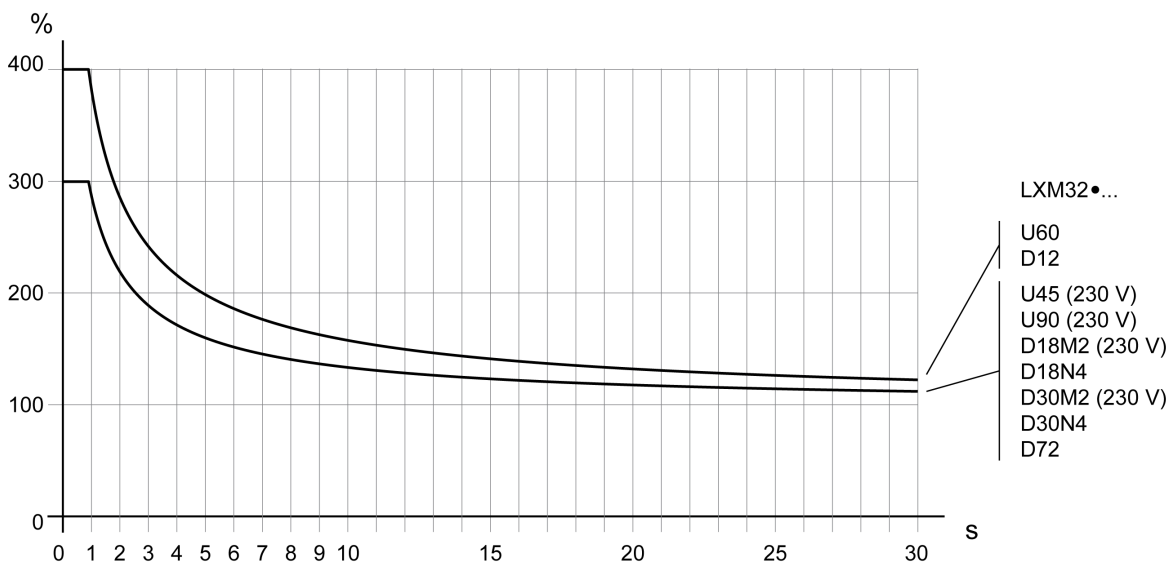

DC Bus Data

DC Bus Data for Single-Phase Drives

Characteristic	Unit	Value							
		LXM32-U45M2		LXM32-U90M2		LXM32-D18M2		LXM32-D30M2	
Nominal voltage	V	115	230	115	230	115	230	115	230
Nominal voltage DC bus	V	163	325	163	325	163	325	163	325
Undervoltage limit	V	55	130	55	130	55	130	55	130
Voltage limit: activation of Quick Stop	V	60	140	60	140	60	140	60	140
Oversvoltage limit	V	260 ⁽¹⁾ / 450	450	260 ⁽¹⁾ / 450	450	260 ⁽¹⁾ / 450	450	260 ⁽¹⁾ / 450	450
Maximum continuous power via DC bus	kW	0.2	0.5	0.4	0.9	0.8	1.6	0.8	2.2
Maximum continuous current via DC bus	A	1.5	1.5	3.2	3.2	6.0	6.0	10.0	10.0

(1) Can be set via parameter *MON_DCbusVdcThresh*.

DC Bus Data for Three-Phase Drives

Characteristic	Unit	Value								
		LXM32-U60N4			LXM32-D12N4			LXM32-D18N4		
Nominal voltage	V	208	400	480	208	400	480	208	400	480
Nominal voltage DC bus	V	294	566	679	294	566	679	294	566	679
Undervoltage limit	V	150	350	350	150	350	350	150	350	350
Voltage limit: activation of Quick Stop	V	160	360	360	160	360	360	160	360	360
Oversvoltage limit	V	450 ⁽¹⁾ / 820	820	820	450 ⁽¹⁾ / 820	820	820	450 ⁽¹⁾ / 820	820	820
Maximum continuous power via DC bus	kW	0.4	0.8	0.8	0.8	1.6	1.6	1.7	3.3	3.3
Maximum continuous current via DC bus	A	1.5	1.5	1.5	3.2	3.2	3.2	6.0	6.0	6.0

(1) Can be set via parameter *MON_DCbusVdcThresh*.

Characteristic	Unit	Value					
		LXM32-D30N4			LXM32-D72N4		
Nominal voltage	V	208	400	480	208	400	480
Nominal voltage DC bus	V	294	566	679	294	566	679
Undervoltage limit	V	150	350	350	150	350	350
Voltage limit: activation of Quick Stop	V	160	360	360	160	360	360
Oversvoltage limit	V	450 ⁽¹⁾ / 820	820	820	450 ⁽¹⁾ / 820	820	820
Maximum continuous power via DC bus	kW	2.8	5.6	5.6	6.5	13.0	13.0
Maximum continuous current via DC bus	A	10.0	10.0	10.0	22.0	22.0	22.0

(1) Can be set via parameter *MON_DCbusVdcThresh*.

24 Vdc Control Supply

Description

The 24 Vdc control supply must meet the requirements of IEC 61131-2 (PELV standard power supply unit):

Characteristic	Unit	Value
Input voltage	Vdc	24 (-15/+20 %) ⁽¹⁾
Input current (without load)	A	≤1 ⁽²⁾
Residual ripple	%	<5
Inrush current		Charging current for capacitor C= 1.8 mF
(1) For connection of motors without holding brake. See figure below for motors with holding brake		
(2) Input current: holding brake not considered.		

24 Vdc Control Supply in the Case of Motor with Holding Brake

If a motor with holding brake is connected, the 24 Vdc control supply must be adjusted according to the connected motor type, the motor cable length and the cross section of the wires for the holding brake. The following diagram applies to the motor cables available as accessories, see [Accessories and Spare Parts](#), page 373. See the diagram for the voltage that must be available at CN2 for releasing the holding brake. The voltage tolerance is ±5 %.

24 Vdc control supply in the case of motor with holding brake: the voltage depends on the motor type, the motor cable length and the conductor cross section.

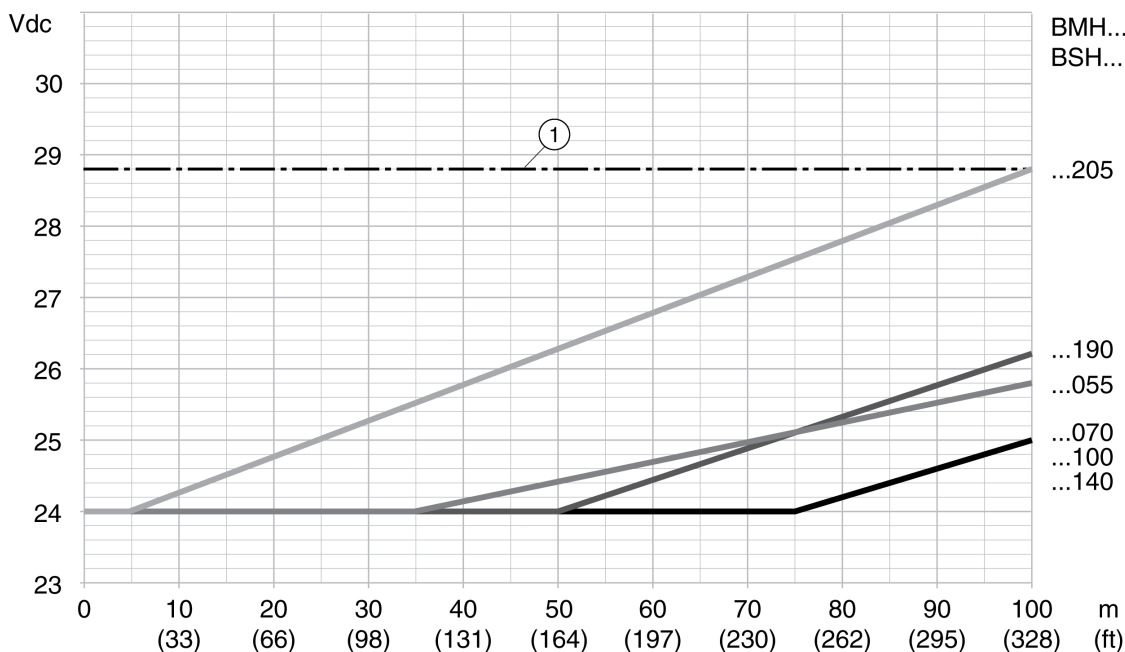

1 Maximum voltage of the 24 Vdc control supply

Signals

Logic Type

The digital inputs and outputs of this product can be wired to enable positive logic or negative logic.

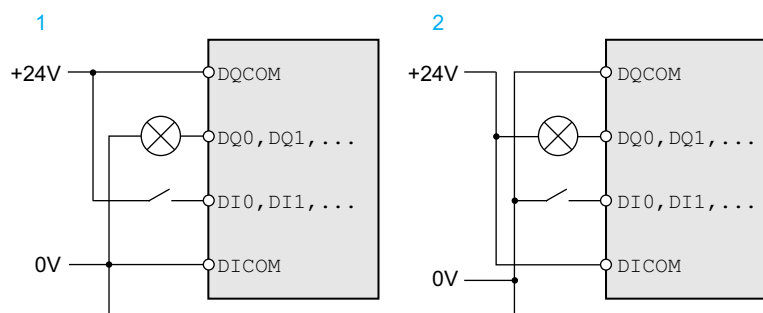

Logic type	Active state
(1) Positive logic	Output supplies current (source output) Current flows to the input (sink input)
(2) Negative logic	Output draws current (sink output) Current flows from the input (source input)

Signal inputs are protected against reverse polarity, outputs are short-circuit protected. The inputs and outputs are functionally isolated.

Refer to [Logic Type](#), page 63 for more information on sinking, sourcing and positive and negative logic.

Analog Input Signals

Characteristic	Unit	Value
Voltage range of differential input circuit	V	-10 ... 10
Input resistance, typical	kΩ	20
Resolution		14 bits
Sampling period	ms	0.25

Digital Input Signals 24 V

When wired as sinking inputs, the levels of the digital inputs comply with IEC 61131-2, type 1. The electrical characteristics are also valid when wired as sourcing inputs unless otherwise indicated.

Characteristic	Unit	Value
Input voltage - sinking inputs	Vdc	
Level 0		-3 ... 5
Level 1		15 ... 30
Input voltage - sourcing inputs (at 24 Vdc)	Vdc	
Level 0		>19
Level 1		<9
Input current (at 24 Vdc)	mA	5
Debounce time (software) ⁽¹⁾⁽²⁾	ms	1.5 (default value)
Hardware switching time	μs	15

Characteristic	Unit	Value
Rising edge (level 0 -> 1)		
Falling edge (level 1 -> 0)		150
Jitter (capture inputs)	µs	<2
(1) Adjustable via parameter (sampling period 250µs)		
(2) If the capture inputs are used for capture then the debounce time is not applied.		

Digital Output Signals 24 V

When wired as sourcing outputs, the levels of the digital outputs comply with IEC 61131-2. The electrical characteristics are also valid when wired as sinking outputs unless otherwise indicated.

Characteristic	Unit	Value
Nominal supply voltage	Vdc	24
Voltage range for supply voltage	Vdc	19.2 ... 30
Nominal output voltage - sourcing outputs	Vdc	24
Nominal output voltage - sinking outputs	Vdc	0
Voltage drop at 100 mA load	Vdc	≤3
Maximum current per output	mA	100

Input Signals Safety Function STO

The inputs for the safety function STO (inputs *STO_A* and *STO_B*) can only be wired for sinking inputs. Observe the information provided in section Functional Safety, page 71.

Characteristic	Unit	Value
Input voltage	Vdc	
Level 0		-3 ... 5
Level 1		15 ... 30
Input current (at 24 Vdc)	mA	5
Debounce time <i>STO_A</i> and <i>STO_B</i>	ms	>1
Detection of signal differences between <i>STO_A</i> and <i>STO_B</i>	s	>1
Response time of safety function STO	ms	≤10

Holding Brake Output CN11

The 24 Vdc holding brake of the BMH motor or the BSH motor can be connected to the output CN11. Data of output CN11:

Characteristic	Unit	Value
Output voltage ⁽¹⁾	V	Voltage at 24 Vdc control supply CN2 minus 0.8 V
Maximum switching current	A	1.7
Energy inductive load ⁽²⁾	Ws	1.5
(1) See 24 Vdc Control Supply, page 36		
(2) Time between switch off procedures: > 1 s		

Encoder Signals

The encoder signals comply with the Stegmann Hiperface specification.

Characteristic	Unit	Value
Output voltage for encoder	V	10
Output current for encoder	mA	100
SIN/COS input signal voltage range	-	1 V _{pp} with 2.5 V offset, 0.5 V _{pp} at 100 kHz
Input resistance	Ω	120

The output voltage is short-circuit protected and overload protected.

Output PTO (CN4)

Description

5 V signals are available at the PTO (Pulse Train Out, CN4) output. Depending on parameter *PTO_mode*, these signals are ESIM signals (encoder simulation) or directly transmitted PTI input signals (P/D signals, A/B signals, CW/CCW signals). The PTO output signals can be used as PTI input signals for another device. The PTO output signals have 5 V, even if the PTI input signal is a 24 V signal.

Output Signal PTO

The PTO output signals comply with the RS422 interface specification. Due to the input current of the optocoupler in the input circuit, a parallel connection of a driver output to several devices is not permitted.

The basic resolution of the encoder simulation at quadruple resolution is 4096 increments per revolution in the case of rotary motors.

Time chart with A, B and index pulse signal, counting forwards and backwards

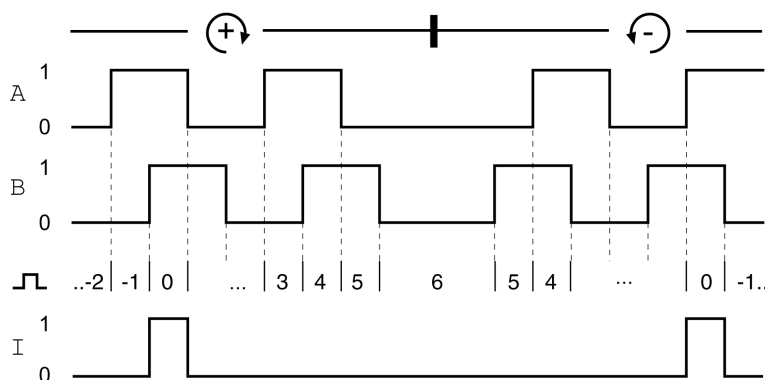

Characteristic	Unit	Value
Logic level		As per RS422 ⁽¹⁾
Output frequency per signal	kHz	≤500
Motor increments per second	Inc/s	≤1.6 * 10 ⁶
(1) Due to the input current of the optocoupler in the input circuit, a parallel connection of a driver output to several devices is not permitted.		

The device connected to the PTO output must be able to process the specified motor increments per second. Even at low velocities, (medium PTO frequency in the kHz range), edges may change at up to 1.6 MHz.

Input PTI (CN5)

Description

5 V signals or 24 V signals can be connected to the PTI (Pulse Train In) input.

The following signals can be connected:

- A/B signals (*ENC_A/ENC_B*)
- P/D signals (*PULSE/DIR*)
- CW/CCW signals (*CW/CCW*)

Input Circuit and Selection of Method

The input circuit and the selected method affect the maximum permissible input frequency and the maximum permissible line length:

Input circuit		RS422	Push pull	Open collector
Minimum input frequency with method position synchronization	Hz	0	0	0
Minimum input frequency with method velocity synchronization	Hz	100	100	100
Maximum input frequency	MHz	1	0.2	0.01
Maximum line length	m (ft)	100 (328)	10 (32.8)	1 (3.28)

Signal input circuits: RS422, Push Pull and Open Collector

5 Vdc

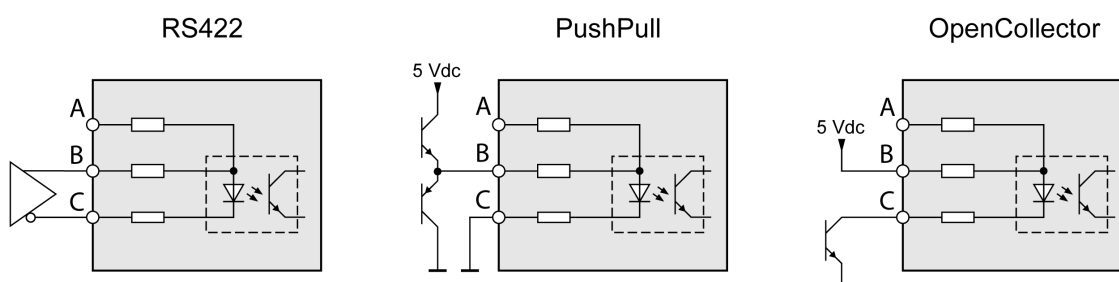

24 Vdc

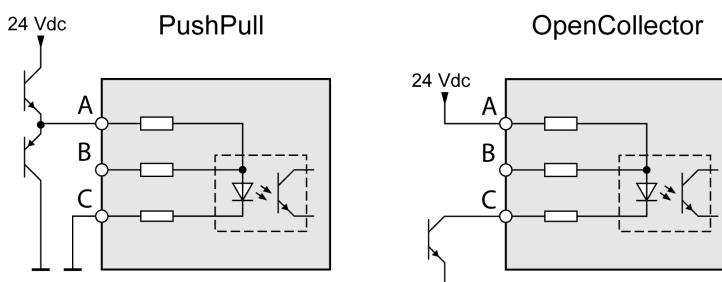

Input	Pin ⁽¹⁾	RS422 ⁽²⁾	5V	24V
A	Pin 7	Reserved	Reserved	<i>PULSE</i> (24V) <i>ENC_A</i> (24V) <i>CW</i> (24V)
	Pin 8	Reserved	Reserved	<i>DIR</i> (24V) <i>ENC_B</i> (24V) <i>CCW</i> (24V)
B	Pin 1	<i>PULSE</i> (5V) <i>ENC_A</i> (5V) <i>CW</i> (5V)	<i>PULSE</i> (5V) <i>ENC_A</i> (5V) <i>CW</i> (5V)	Reserved
	Pin 4	<i>DIR</i> (5V) <i>ENC_B</i> (5V) <i>CCW</i> (5V)	<i>DIR</i> (5V) <i>ENC_B</i> (5V) <i>CCW</i> (5V)	Reserved
C	Pin 2	<i>PULSE</i> <i>ENC_A</i> <i>CW</i>	<i>PULSE</i> <i>ENC_A</i> <i>CW</i>	<i>PULSE</i> <i>ENC_A</i> <i>CW</i>
	Pin 5	<i>DIR</i> <i>ENC_B</i> <i>CCW</i>	<i>DIR</i> <i>ENC_B</i> <i>CCW</i>	<i>DIR</i> <i>ENC_B</i> <i>CCW</i>

(1) Observe the different pairing in the case of twisted pair:

Pin 1 / pin 2 and pin 4 / pin 5 for RS422 and 5V

pin 7 / pin 2 and pin 8 / pin 5 for 24V

(2) Due to the input current of the optocoupler in the input circuit, a parallel connection of a driver output to several devices is not permitted.

Function A/B Signals

External A/B signals can be supplied via the PTI input as reference values in operating mode Electronic Gear.

Signal	Value	Function
Signal A before signal B	0 -> 1	Movement in positive direction
Signal B before signal A	0 -> 1	Movement in negative direction

Time chart with A/B signal, counting forwards and backwards

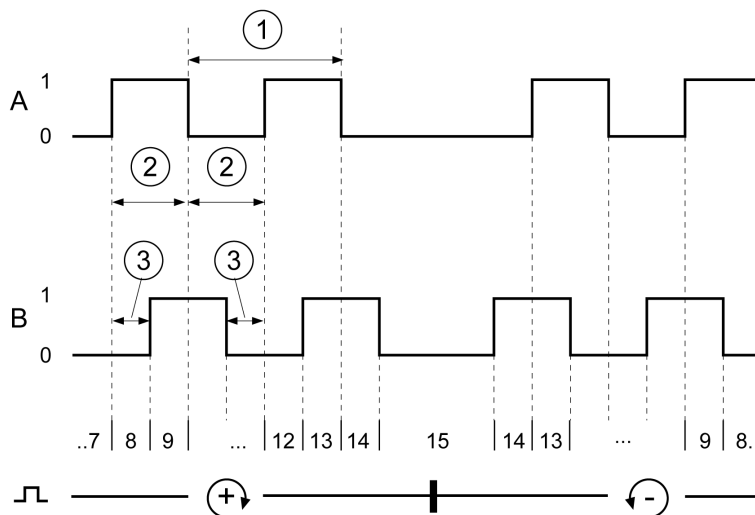

Times for pulse/direction	Minimum value
(1) Cycle duration A, B	1 μ s
(2) Pulse duration	0.4 μ s
(3) Lead time (A, B)	200 ns

Function P/D Signals

External P/D signals can be supplied via the PTI input as reference values in the operating mode Electronic Gear.

The motor performs a movement in the case of a rising edge of the *PULSE* signal. The direction is controlled with the *DIR* signal.

Signal	Value	Function
<i>PULSE</i>	0 -> 1	Motor movement
<i>DIR</i>	0 / open	Positive direction

Time chart with pulse/direction signal

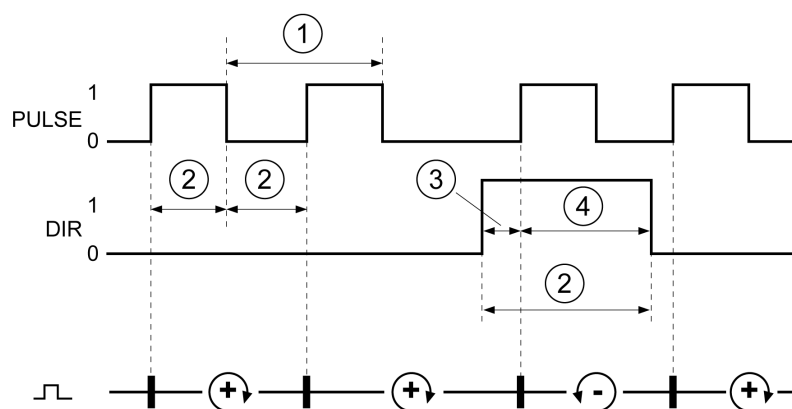

Times for pulse/direction	Minimum value
(1) Cycle duration (pulse)	1 μ s
(2) Pulse duration (pulse)	0.4 μ s

Times for pulse/direction	Minimum value
(3) Lead time (Dir-Pulse)	0 μ s
(4) Hold time (Pulse-Dir)	0.4 μ s

Function CW/CCW Signals

External CW/CCW signals can be supplied via the PTI input as reference values in operating mode Electronic Gear.

The motor performs a movement in positive direction in the case of a rising edge of the CW signal. The motor performs a movement in negative direction in the case of a rising edge of the CCW signal.

Signal	Value	Function
CW	0 -> 1	Movement in positive direction
CCW	0 -> 1	Movement in negative direction

Time chart with "CW/CCW"

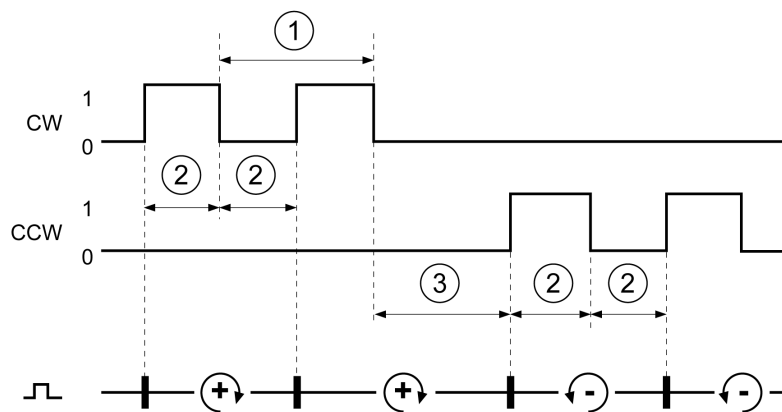

Times for pulse/direction	Minimum value
(1) Cycle duration CW, CCW	1 μ s
(2) Pulse duration	0.4 μ s
(3) Lead time (CW-CCW, CCW-CW)	0 μ s

Capacitor and Braking Resistor

Description

The drive has an internal capacitor and an internal braking resistor. If the internal capacitor and the internal braking resistor are insufficient for the dynamics of the application, one or more external braking resistors must be used.

The resistance values for external braking resistors must not be below the specified minimum resistance. If an external braking resistor is activated by means of the appropriate parameter, the internal braking resistor is deactivated.

Data of Internal Capacitor

Characteristic	Unit	Value			
		LXM32-U45M2	LXM32-U90M2	LXM32-D18M2	LXM32-D30M2
Capacitance of internal capacitor	µF	390	780	1170	1560
Parameter <i>DCbus_compat</i> = 0 (default value)					
Energy absorption of internal capacitors E_{var} at nominal voltage 115 V +10%	Ws	5	9	14	18
Energy absorption of internal capacitors E_{var} at nominal voltage 200 V +10%	Ws	17	34	52	69
Energy absorption of internal capacitors E_{var} at nominal voltage 230 V +10%	Ws	11	22	33	44
Parameter <i>DCbus_compat</i> = 1 (reduced switch-on voltage)					
Energy absorption of internal capacitors E_{var} at nominal voltage 115 V +10%	Ws	24	48	73	97
Energy absorption of internal capacitors E_{var} at nominal voltage 200 V +10%	Ws	12	23	35	46
Energy absorption of internal capacitors E_{var} at nominal voltage 230 V +10%	Ws	5	11	16	22

Characteristic	Unit	Value				
		LXM32-U60-N4	LXM32-D12-N4	LXM32-D18-N4	LXM32-D30-N4	LXM32-D72-N4
Capacitance of internal capacitor	µF	110	195	390	560	1120
Energy absorption of internal capacitors E_{var} at nominal voltage 208 V +10%	Ws	4	8	16	22	45
Energy absorption of internal capacitors E_{var} at nominal voltage 380 V +10%	Ws	14	25	50	73	145
Energy absorption of internal capacitors E_{var} at nominal voltage 400 V +10%	Ws	12	22	43	62	124
Energy absorption of internal capacitors E_{var} at nominal voltage 480 V +10%	Ws	3	5	10	14	28
Parameter <i>DCbus_compat</i> has no effect in the case of three-phase devices						

Data of Internal Braking Resistor

Characteristic	Unit	Value			
		LXM32-U45M2	LXM32-U90M2	LXM32-D18M2	LXM32-D30M2
Resistance value of internal braking resistor	Ω	94	47	20	10
Continuous power internal braking resistor P_{PR}	W	10	20	40	60
Peak energy E_{CR}	Ws	82	166	330	550
Parameter <i>DCbus_compat</i> = 0 (default value)					

Characteristic	Unit	Value			
		LXM32-U45M2	LXM32-U90M2	LXM32-D18M2	LXM32-D30M2
Switch-on voltage of braking resistor at nominal voltage 115 V	V	236	236	236	236
Switch-on voltage of braking resistor at nominal voltage 200 V and 230 V	V	430	430	430	430
Parameter DCbus_compat = 1 (reduced switch-on voltage)					
Switch-on voltage of braking resistor	V	395	395	395	395

Characteristic	Unit	Value				
		LXM32-U60-N4	LXM32-D12-N4	LXM32-D18-N4	LXM32-D30-N4	LXM32-D72-N4
Resistance value of internal braking resistor	Ω	132	60	30	30	10
Continuous power internal braking resistor P _{PR}	W	20	40	60	100	150
Peak energy E _{CR}	Ws	200	400	600	1000	2400
Switch-on voltage of braking resistor at nominal voltage 208 V	V	430	430	430	430	430
Switch-on voltage of braking resistor at nominal voltage 380 V, 400 V and 480 V	V	780	780	780	780	780
Parameter DCbus_compat has no effect in the case of three-phase devices						

Data for External Braking Resistor

Characteristic	Unit	Value			
		LXM32-U45M2	LXM32-U90M2	LXM32-D18M2	LXM32-D30M2
Minimum resistance value of external braking resistor	Ω	68	36	20	10
Maximum resistance value of external braking resistor ⁽¹⁾	Ω	110	55	27	16
Maximum continuous power of external braking resistor	W	200	400	600	800
Parameter DCbus_compat = 0 (default value)					
Switch-on voltage of braking resistor at nominal voltage 115 V	V	236	236	236	236
Switch-on voltage of braking resistor at nominal voltage 200 V and 230 V	V	430	430	430	430
Parameter DCbus_compat = 1 (reduced switch-on voltage)					
Switch-on voltage of braking resistor	V	395	395	395	395
(1) The maximum specified braking resistor can derate the peak power of the device. Depending on the application, it is possible to use a higher ohm resistor.					

Characteristic	Unit	Value				
		LXM32-U60-N4	LXM32-D12-N4	LXM32-D18-N4	LXM32-D30-N4	LXM32-D72-N4
Minimum resistance value of external braking resistor	Ω	70	47	25	15	8
Maximum resistance value of external braking resistor ⁽¹⁾	Ω	145	73	50	30	12
Maximum continuous power of external braking resistor	W	200	500	800	1500	3000
Switch-on voltage of braking resistor at nominal voltage 208 V	V	430	430	430	430	430
Switch-on voltage of braking resistor at nominal voltage 380 V, 400 V and 480 V	V	780	780	780	780	780

Characteristic	Unit	Value				
		LXM32•U60-N4	LXM32•D12-N4	LXM32•D18-N4	LXM32•D30-N4	LXM32•D72-N4
Parameter <i>DCbus_compat</i> has no effect in the case of three-phase devices						
(1) The maximum specified braking resistor can derate the peak power of the device. Depending on the application, it is possible to use a higher ohm resistor.						

Data of External Braking Resistors (Accessories)

Characteristic	Unit	Value							
		VW3-A7601Rx-x	VW3-A7602Rx-x	VW3-A7603Rx-x	VW3-A7604Rx-x	VW3-A7605Rx-x	VW3-A7606Rx-x	VW3-A7607Rx-x	VW3-A7608Rx-x
Resistance	Ω	10	27	27	27	72	72	72	100
Continuous power	W	400	100	200	400	100	200	400	100
Maximum time in braking at 115 V	s	3	1.8	4.2	10.8	6.36	16.8	42	10.8
Peak power at 115 V	kW	5.6	2.1	2.1	2.1	0.8	0.8	0.8	0.6
Maximum peak energy at 115 V	kWs	16.7	3.7	8.7	22.3	4.9	13	32.5	6
Maximum time in braking at 230 V	s	0.72	0.55	1.08	2.64	1.44	3.72	9.6	2.4
Peak power at 230 V	kW	18.5	6.8	6.8	6.8	2.6	2.6	2.6	1.8
Maximum peak energy at 230 V	kWs	13.3	3.8	7.4	18.1	3.7	9.6	24.7	4.4
Maximum time in braking at 400 V and 480 V	s	0.12	0.084	0.216	0.504	0.3	0.78	1.92	0.48
Peak power at 400 V and 480 V	kW	60.8	22.5	22.5	22.5	8.5	8.5	8.5	6.1
Maximum peak energy at 400 V and 480 V	kWs	7.3	1.9	4.9	11.4	2.5	6.6	16.2	2.9
Degree of protection		IP65	IP65	IP65	IP65	IP65	IP65	IP65	IP65
UL approval (file no.)		-	E233422	E233422	-	E233422	E233422	-	E233422

Characteristic	Unit	Value	
		VW3A7733	VW3A7734
Resistance	Ω	16	10
Continuous power	W	960	960
Maximum time in braking at 115 V	s	20	10
Peak power at 115 V	kW	3.5	5.6
Maximum peak energy at 115 V	kWs	70	59
Maximum time in braking at 230 V	s	3.8	1.98
Peak power at 230 V	kW	11.6	18.5
Maximum peak energy at 230 V	kWs	44	36.5
Maximum time in braking at 400 V and 480 V	s	0.7	0.37
Peak power at 400 V and 480 V	kW	38	60.8
Maximum peak energy at 400 V and 480 V	kWs	26.6	22.5
Degree of protection		IP20	IP20
UL approval (file no.)		E226619	E226619

Electromagnetic Emission

Overview

The products described in the present manual meet the EMC requirements as per IEC 61800-3 if the EMC measures described in the present manual are implemented.

⚠ WARNING
ELECTROMAGNETIC DISTURBANCES OF SIGNALS AND DEVICES
Use proper EMI shielding techniques to help prevent unintended device operation.
Failure to follow these instructions can result in death, serious injury, or equipment damage.

These types of devices are not intended to be used on a low-voltage public network which supplies domestic premises. Radio frequency interference is expected if used in such a network.

⚠ WARNING
RADIO INTERFERENCE
Do not use these products in domestic electrical networks.
Failure to follow these instructions can result in death, serious injury, or equipment damage.

EMC Categories

The following categories for emission as per IEC 61800-3 are reached if the EMC measures described in the present manual are implemented.

Emission type	Category	Category
	LXM32...M2	LXM32...N4
Conducted emission		
Motor cable length ≤10 m (≤32.81 ft)	Category C2	Category C3
Motor cable length 10 ... ≤20 m (32.81 ... ≤65.62 ft)	Category C3	Category C3
Radiated emission		
Motor cable length ≤20 m (65.62 ft)	Category C3	Category C3

EMC Categories With External Mains Filter

The following categories for emission as per IEC 61800-3 are reached if the EMC measures described in the present manual are implemented and if the external mains filters offered as accessories are used.

Emission type	Category	Category
	LXM32••••M2	LXM32••••N4
Conducted emission		
Motor cable length ≤20 m (65.62 ft)	Category C1	Category C1
Motor cable length >20 ... ≤50 m (>65.62 ... ≤164.00 ft)	Category C2	Category C2
Motor cable length >50 ... ≤100 m (>164.00 ... ≤328.01 ft)	Category C3	Category C3
Radiated emission		
Motor cable length ≤100 m (328.01 ft)	Category C3	Category C3

Assignment of External Mains Filters

Single-phase drives	Mains filter reference
LXM32•U45M2 (230 V, 1,5 A)	VW3A4420 (9 A)
LXM32•U90M2 (230 V, 3 A)	VW3A4420 (9 A)
LXM32•D18M2 (230 V, 6 A)	VW3A4421 (16 A)
LXM32•D30M2 (230 V, 10 A)	VW3A4421 (16 A)

Three-phase drives	Mains filter reference
LXM32•U60N4 (480 V, 1,5 A)	VW3A4422 (15 A)
LXM32•D12N4 (480 V, 3 A)	VW3A4422 (15 A)
LXM32•D18N4 (480 V, 6 A)	VW3A4422 (15 A)
LXM32•D30N4 (480 V, 10 A)	VW3A4422 (15 A)
LXM32•D72N4 (480 V, 24 A)	VW3A4423 (25 A)

Several drives can be connected to a common external mains filter.

Prerequisites:

- Single-phase drives may only be connected to single-phase mains filters; three-phase drives may only be connected to three-phase mains filters.
- The total input current of the connected drives must be smaller than or equal to the permissible nominal current of the mains filter.

Nonvolatile Memory and Memory Card

Nonvolatile Memory

The following table shows characteristics for the nonvolatile memory:

Characteristic	Value
Minimum number of writing cycles	100000
Type	EEPROM

Memory Card

The following table shows characteristics for the memory card:

Characteristic	Value
Minimum number of writing cycles	100000
Minimum number of insertion cycles	1000

Memory Card Holder

The following table shows characteristics for the memory card holder:

Characteristic	Value
Minimum number of insertion cycles	5000

Conditions for UL 508C and CSA

General

If the product is used to comply with UL 508C or CSA, the following conditions must also be met:

Ambient Temperature During Operation

Characteristic	Unit	Value
Surrounding air temperature	°C	0 ... 50
	(°F)	(32 ... 122)

Fuses

Use fuses as per UL 248.

Characteristic	Unit	Value	
		LXM32-***M2	LXM32-***N4
Maximum fuse rating of fuse to be connected upstream	A	25	30
Class of fuse		CC or J	CC or J
Short-circuit current rating (SCCR)	kA	12	12

Circuit Breaker

Characteristic	Unit	Value				
		LXM32-U45-M2, LXM32-U90-M2	LXM32-D18-M2, LXM32-D30-M2	LXM32-U60N4, LXM32-D12N4, LXM32-D18N4		LXM32-D30-N4, LXM32-D72-N4
Catalog number of type E combination motor controller		GV2P14 or GV3P25	GV3P25	GV2P14 or GV3P25	GV2P22	GV2P22
Short-circuit current rating (SCCR)	kA	12	12	12	10	10

Wiring

Use at least 75 °C (167 °F) copper conductors.

400/480 V Three-Phase Devices

400/480 V three-phase devices may only be operated via mains up to 480Y/277Vac.

Overvoltage Category

Use only in overvoltage category III or where the maximum available Rated Impulse Withstand Voltage Peak is equal or less than 4000 Volts.

Motor Overload Protection

This equipment provides Solid State Motor Overload Protection at 200 % of maximum FLA (Full Load Ampacity).

Engineering

Electromagnetic Compatibility (EMC)

General

EMC-Compliant Wiring

This drive meets the EMC requirements according to the standard IEC 61800-3 if the measures described in this manual are implemented during installation.

Signal interference can cause unexpected responses of the drive system and of other equipment in the vicinity of the drive system.

▲ WARNING

SIGNAL AND EQUIPMENT INTERFERENCE

- Install the wiring in accordance with the EMC requirements described in the present document.
- Verify compliance with the EMC requirements described in the present document.
- Verify compliance with all EMC regulations and requirements applicable in the country in which the product is to be operated and with all EMC regulations and requirements applicable at the installation site.

Failure to follow these instructions can result in death, serious injury, or equipment damage.

▲ WARNING

ELECTROMAGNETIC DISTURBANCES OF SIGNALS AND DEVICES

Use proper EMI shielding techniques to help prevent unintended device operation.

Failure to follow these instructions can result in death, serious injury, or equipment damage.

See Electromagnetic Emission, page 49 for the EMC categories.

Overview of wiring with EMC details

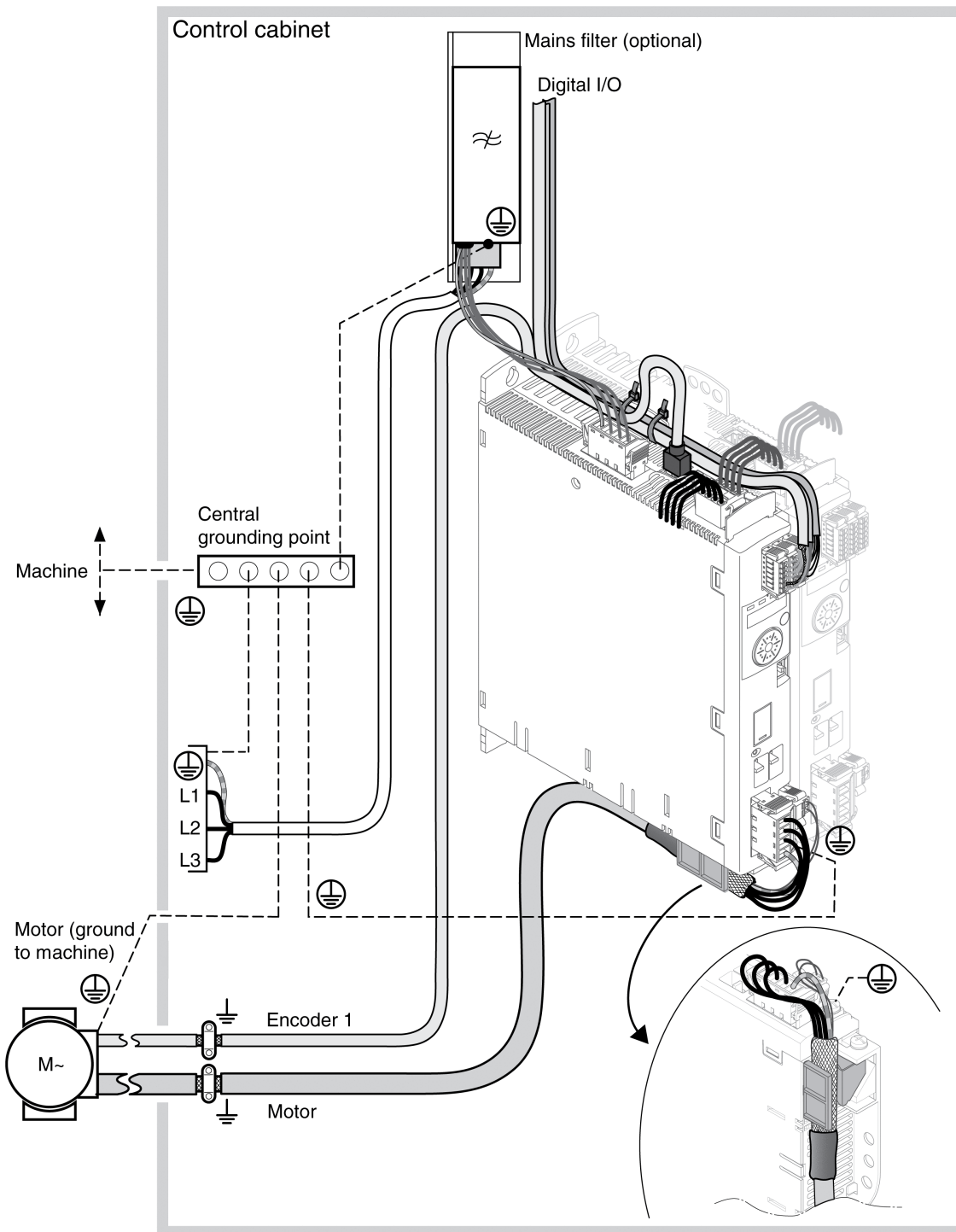

EMC Requirements for the Control Cabinet

EMC measures	Objective
Use mounting plates with good electrical conductivity, connect large surface areas of metal parts, remove paint from contact areas.	Good conductivity due to large surface contact.
Ground the control cabinet, the control cabinet door and the mounting plate with ground straps or ground wires. The conductor cross section must be at least 10 mm ² (AWG 6).	Reduces emissions.

EMC measures	Objective
Install switching devices such as power contactors, relays or solenoid valves with interference suppression units or arc suppressors (for example, diodes, varistors, RC circuits).	Reduces mutual interference
Do not install power components and control components adjacent to one another.	Reduces mutual interference

Shielded Cables

EMC measures	Objective
Connect large surface areas of cable shields, use cable clamps and ground straps.	Reduces emissions.
Use cable clamps to connect a large surface area of the shields of all shielded cables to the mounting plate at the control cabinet entry.	Reduces emissions.
Ground shields of digital signal wires at both ends by connecting them to a large surface area or via conductive connector housings.	Reduces interference affecting the signal wires, reduces emissions
Ground the shields of analog signal wires directly at the drive (signal input); insulate the shield at the other cable end or ground it via a capacitor (for example, 10 nF).	Reduces ground loops due to low-frequency interference.
Use only shielded motor cables with copper braid and a coverage of at least 85%, ground a large surface area of the shield at both ends.	Diverts interference currents in a controlled way, reduces emissions.

Cable Installation

EMC measures	Objective
Do not route fieldbus cables and signal wires in a single cable duct together with lines with DC and AC voltages of more than 60 V. (Fieldbus cables, signal lines and analog lines may be in the same cable duct) Use separate cable ducts at least 20 cm (7.87 in) apart.	Reduces mutual interference
Keep cables as short as possible. Do not install unnecessary cable loops, use short cables from the central grounding point in the control cabinet to the external ground connection.	Reduces capacitive and inductive interference.
Use equipotential bonding conductors in the following cases: wide-area installations, different voltage supplies and installation across several buildings.	Reduces current in the cable shield, reduces emissions.
Use fine stranded equipotential bonding conductors.	Diverts high-frequency interference currents.
If motor and machine are not conductively connected, for example by an insulated flange or a connection without surface contact, you must ground the motor with a ground strap or a ground wire. The conductor cross section must be at least 10 mm ² (AWG 6).	Reduces emissions, increases immunity.
Use twisted pair for the DC supply.	Reduces interference affecting the signal cables, reduces emissions.

Power Supply

EMC measures	Objective
Operate product on mains with grounded neutral point.	Enables effectiveness of mains filter.
Surge arrester if there is a risk of overvoltage.	Reduces the risk of damage caused by overvoltage.

Motor and Encoder Cables

Motor and encoder cables require particular attention in terms of EMC. Use only pre-assembled cables (see *Accessories and Spare Parts*, page 373) or cables that comply with the specifications (see *Cables and Signals*, page 58) and implement the EMC measures described below.

EMC measures	Objective
Do not install switching elements in motor cables or encoder cables.	Reduces interference.
Route the motor cable at a distance of at least 20 cm (7.87 in) from the signal cable or use shielding plates between the motor cable and signal cable.	Reduces mutual interference
For long lines, use equipotential bonding conductors.	Reduces current in the cable shield.
Route the motor cable and encoder cable without cutting them. ⁽¹⁾	Reduces emission.
(1) If a cable has to be cut for the installation, it has to be connected with shield connections and a metal housing at the point of the cut.	

Additional Measures for EMC Improvement

Depending on the application, the following measures can improve the EMC-dependent values:

EMC measures	Objective
Use mains reactors	Reduces mains harmonics, prolongs product service life.
Use external mains filters	Improves the EMC limit values.
Install in a closed control cabinet with increased shielding.	Improves the EMC limit values.

Deactivating the Y Capacitors

Description

The ground connections of the internal Y capacitors can be disconnected (deactivation). Usually, it is not required to deactivate the ground connection of the Y capacitors.

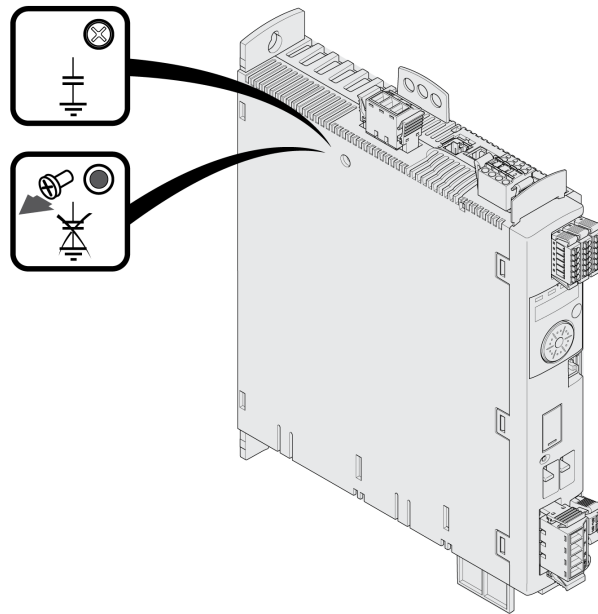

To deactivate the Y capacitors, remove the screw. Keep this screw so you can reactivate the Y capacitors, if required.

The drive no longer complies with the EMC limit values specified if the Y capacitors are deactivated.

Cables and Signals

Cables - General

Suitability of the Cables

Cables must not be twisted, stretched, crushed or bent. Use only cables that comply with the cable specification. Consider the following in determining suitability of the cables:

- Suitable for drag chain applications
- Temperature range
- Chemical resistance
- Outdoor installation
- Underground installation

Connecting Shields

Shield connection possibilities:

- Motor cable: The motor cable shield is fastened in the shield clamp at the bottom of the device.
- Shields of the analog cable and the I/O wires to signal *SHLD* of connector CN6.
- Other cables: The shields are connected to the shield connection at the bottom of the device.
- Alternative: Connect the shield via shield clamps and rail, for example.

Equipotential Bonding Conductors

Potential differences can result in excessive currents on the cable shields. Use equipotential bonding conductors to reduce currents on the cable shields. The equipotential bonding conductor must be rated for the maximum current.

▲ WARNING

UNINTENDED EQUIPMENT OPERATION

- Ground cable shields for all fast I/O, analog I/O, and communication signals at a single point. ¹⁾
- Route communications and I/O cables separately from power cables.

Failure to follow these instructions can result in death, serious injury, or equipment damage.

¹⁾ Multipoint grounding is permissible if connections are made to an equipotential ground plane dimensioned to help avoid cable shield damage in the event of power system short-circuit currents.

Conductor Cross Sections According to Method of Installation

The following sections describe the conductor cross sections for two methods of installation:

- Method of installation B2:
Cables in conduits or cable trunking systems
- Method of installation E:
Cables on open cable trays

Cross section in mm ² (AWG)	Current-carrying capacity with method of installation B2 in A ⁽¹⁾	Current carrying capacity with method of installation E in A ⁽¹⁾
0.75 (18)	8.5	10.4
1 (16)	10.1	12.4
1.5 (14)	13.1	16.1
2.5 (12)	17.4	22
4 (10)	23	30
6 (8)	30	37
10 (6)	40	52
16 (4)	54	70
25 (2)	70	88

(1) Values as per IEC 60204-1 for continuous operation, copper conductors and ambient air temperature 40 °C (104 °F). See IEC 60204-1 for additional information. The table is an excerpt from this standard and also shows cable cross-sections that are not applicable with regard to the product.

Note the derating factors for grouping of cables and correction factors for other ambient conditions (IEC 60204-1).

The conductors must have a sufficiently large cross section so that the upstream fuse can trip.

In the case of longer cables, it may be necessary to use a greater conductor cross section to reduce the energy losses.

Overview of the Required Cables

Overview

The properties of the required cables are listed in the table below. Use pre-assembled cables to reduce the risk of wiring errors. Pre-assembled cables can be found in section [Accessories and Spare Parts](#), page 373. If the product is used to comply with the requirements as per UL 508C, the conditions specified in section [Conditions for UL 508C and CSA](#), page 52 must be met.

	Maximum length:	Minimum cross section	Shielded, both ends grounded	Twisted pair	PELV
24 Vdc control supply	-	0.75 mm ² (AWG 18)	-	-	Required
Safety function STO ⁽¹⁾	-	0.75 mm ² (AWG 18)	⁽¹⁾	-	Required
Power stage supply	-	-(²)	-	-	-
Motor phases	-(³)	-(⁴)	Required	-	-
External braking resistor	3 m (9.84 ft)	As power stage supply	Required	-	-
Motor encoder	100 m (328.01 ft)	6 * 0.14 mm ² and 2 * 0.34 mm ² (6 * AWG 24 and 2 * AWG 20)	Required	Required	Required
A/B signals	100 m (328.08 ft)	0.25 mm ² (AWG 22)	Required	Required	Required
PULSE / DIR signals	100 m (328.08 ft)	0.14 mm ² (AWG 24)	Required	Required	Required
CW/CCW signals	100 m (328.08 ft)	0.14 mm ² (AWG 24)	Required	Required	Required
ESIM	100 m (328.08 ft)	0.14 mm ² (AWG 24)	Required	Required	Required
Analog inputs	10 m (32.81 ft)	0.14 mm ² (AWG 24)	Required	Required	Required
Digital inputs / outputs	30 m (98.43 ft)	0.14 mm ² (AWG 24)	-	-	Required

	Maximum length:	Minimum cross section	Shielded, both ends grounded	Twisted pair	PELV
PC, commissioning interface	20 m (65.62 ft)	0.14 mm ² (AWG 24)	Required	Required	Required
<p>(1) Note the installation requirements (protected cable installation), see Functional Safety, page 71.</p> <p>(2) See Connection Power Stage Supply (CN1), page 94</p> <p>(3) Length depends on the required limit values for conducted interference.</p> <p>(4) See Connection Motor Phases and Holding Brake (CN10 and CN11), page 87</p>					

Cable Specifications

General

Using pre-assembled cables helps to reduce the possibility of wiring errors. See Accessories and Spare Parts, page 373.

The genuine accessories have the following properties:

Motor Cable With Connector

Characteristic	Unit	Value					
		VW3-M5100R***	VW3-M5101R***	VW3-M5102R***	VW3-M5103R***	VW3-M5105R***	VW3-M5104R***
Cable jacket, insulation	-	PUR orange (RAL 2003), TPM	PUR orange (RAL 2003), polypropylene (PP)				
Capacitance power wires	pF/m						
Wire/wire		80	80	80	90	85	100
Wire/shield		145	135	150	150	150	160
Number of contacts (shielded)	-	(4 x 1 mm ² + 2 x (2 x 0.75 mm ²))	(4 x 1.5 mm ² + (2 x 1 mm ²))	(4 x 2.5 mm ² + (2 x 1 mm ²))	(4 x 4 mm ² + (2 x 1 mm ²))	(4 x 6 mm ² + (2 x 1 mm ²))	(4 x 10 mm ² + (2 x 1 mm ²))
Connector motor side	-	8-pin circular Y-TEC	8-pin circular M23		8-pin circular M40		
Connector drive side	-	Open					
Cable diameter	mm (in)	11 ± 0.3 (0.43 ± 0.01)	12 ± 0.2 (0.47 ± 0.01)	14.3 ± 0.3 (0.55 ± 0.01)	16.3 ± 0.3 (0.64 ± 0.01)	18.8 ± 0.4 (0.74 ± 0.02)	23.5 ± 0.6 (0.93 ± 0.02)
Minimum bend radius with fixed installation	-	10 times the cable diameter	5 times the cable diameter				
Minimum bend radius with moving installation	-	10 times the cable diameter	7.5 times the cable diameter			10 times the cable diameter	
Nominal voltage	V						
Motor phases		1000	600				
Holding brake		1000	300				
Maximum orderable length	m (ft)	25 (82)	75 (246)				
Permissible temperature range during operation with fixed installation	°C (°F)	-40 ... 80 (-40 ... 176)					
Permissible temperature range during operation with moving installation	°C (°F)	-20 ... 60 (-4 ... 140)	-20 ... 80 (-4 ... 176)				
Certifications / declaration of conformity	-	CE, DESINA					

Motor Cable Without Connector

Characteristic	Unit	Value					
		VW3-M5300R***	VW3-M5301R***	VW3-M5302R***	VW3-M5303R***	VW3-M5305R***	VW3-M5304R***
Cable jacket, insulation	-	PUR orange (RAL 2003), TPM	PUR orange (RAL 2003), polypropylene (PP)				
Capacitance power wires	pF/m						
Wire/wire		80	80	80	90	85	100
Wire/shield		145	135	150	150	150	160
Number of contacts (shielded)	-	(4 x 1 mm ² + 2 x (2 x 0.75 mm ²))	(4 x 1.5 mm ² + (2 x 1 mm ²))	(4 x 2.5 mm ² + (2 x 1 mm ²))	(4 x 4 mm ² + (2 x 1 mm ²))	(4 x 6 mm ² + (2 x 1 mm ²))	(4 x 10 mm ² + (2 x 1 mm ²))
Connector motor side	-	Open					
Connector drive side	-	Open					
Cable diameter	mm (in)	11 ± 0.3 (0.43 ± 0.01)	12 ± 0.2 (0.47 ± 0.01)	14.3 ± 0.3 (0.55 ± 0.01)	16.3 ± 0.3 (0.64 ± 0.01)	18.8 ± 0.4 (0.74 ± 0.02)	23.5 ± 0.6 (0.93 ± 0.02)
Minimum bend radius with fixed installation	-	10 times the cable diameter	5 times the cable diameter				
Minimum bend radius with moving installation	-	10 times the cable diameter	7.5 times the cable diameter			10 times the cable diameter	
Nominal voltage	V						
Motor phases		1000	600				
Holding brake		1000	300				
Maximum orderable length	m (ft)	100 (328)					
Permissible temperature range during operation with fixed installation	°C (°F)	-40 ... 80 (-40 ... 176)					
Permissible temperature range during operation with moving installation	°C (°F)	-20 ... 60 (-4 ... 140)	-20 ... 80 (-4 ... 176)				
Certifications / declaration of conformity	-	CE, c-UR-us, DESINA					

Encoder Cable With and Without Connectors

Characteristic	Unit	Value		
		VW3M8100R***	VW3M8102R***	VW3M8222R***
Cable jacket, insulation	-	PUR green (RAL 6018), polypropylene (PP)		
Capacitance	pF/m	Approx. 135 (wire/wire)		
Number of contacts (shielded)	-	(3 x 2 x 0.14 mm ² + 2 x 0.34 mm ²)		
Connector motor side	-	12-pin circular Y-TEC	12-pin circular M23	Open
Connector drive side	-	10-pin RJ45	10-pin RJ45	Open
Cable diameter	mm (in)	6.8 ± 0.2 (0.27 ± 0.1)		
Minimum bend radius	mm (in)	68 (2.68)		
Nominal voltage	V	300		

Characteristic	Unit	Value		
		VW3M8100R...	VW3M8102R...	VW3M8222R...
Maximum orderable length	m	25	75	100
	(ft)	(82)	(246)	(328)
Permissible temperature range during operation with fixed installation	°C (°F)	-40 ... 80 (-40 ... 176)		
Permissible temperature range during operation with moving installation	°C (°F)	-20 ... 80 (-4 ... 176)		
Certifications / declaration of conformity	-	DESINA		c-UR-us, DESINA

Clearance For Connectors

Straight connectors

Angular connectors

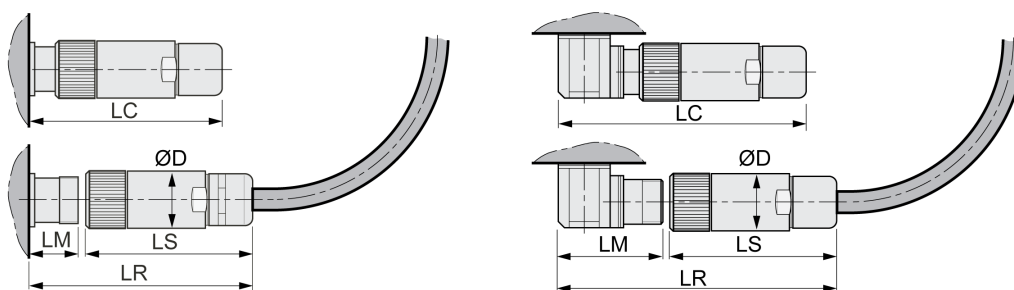

Dimensions		Motor connectors		Encoder connector
		straight		straight
		M23	M40	M23
D	mm (in)	28 (1.1)	46 (1.81)	26 (1.02)
LS	mm (in)	76 (2.99)	100 (3.94)	51 (2.01)
LR	mm (in)	117 (4.61)	155 (6.1)	76 (2.99)
LC	mm (in)	100 (3.94)	145 (5.71)	60 (2.36)
LM	mm (in)	40 (1.57)	54 (2.13)	23 (0.91)

Dimensions		Motor connectors			Encoder connector	
		angular			angular	
		Y-TEC	M23	M40	Y-TEC	M23
D	mm (in)	18.7 (0.74)	28 (1.1)	46 (1.81)	18.7 (0.74)	26 (1.02)
LS	mm (in)	42 (1.65)	76 (2.99)	100 (3.94)	42 (1.65)	51 (2.01)
LR	mm (in)	100 (3.94)	132 (5.2)	191 (7.52)	100 (3.94)	105 (4.13)
LC	mm (in)	89 (3.50)	114 (4.49)	170 (6.69)	89 (3.50)	89 (3.5)
LM	mm (in)	58 (2.28)	55 (2.17)	91 (3.58)	58 (2.28)	52 (2.05)

Logic Type

Overview

The digital inputs and outputs of this product can be wired to enable positive logic or negative logic.

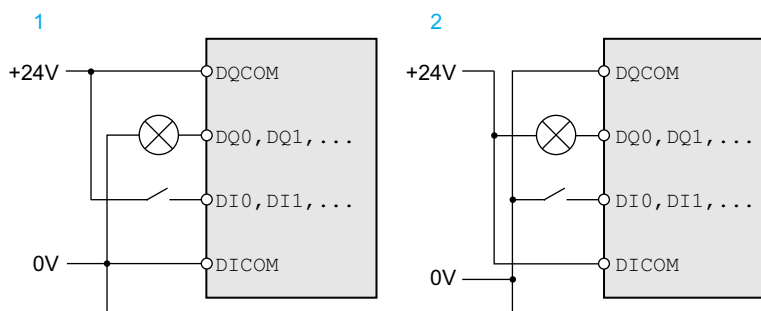

Logic type	Active state
(1) Positive logic	Output supplies current (source output) Current flows to the input (sink input)
(2) Negative logic	Output draws current (sink output) Current flows from the input (source input)

Signal inputs are protected against reverse polarity, outputs are short-circuit protected. The inputs and outputs are functionally isolated.

If negative logic is used, a ground fault of a signal is detected as an On state.

⚠ WARNING
UNINTENDED EQUIPMENT OPERATION
Verify that a short-circuit of a signal cannot cause unintended equipment operation.
Failure to follow these instructions can result in death, serious injury, or equipment damage.

Selection of the Logic Type

The logic type is determined by the wiring of *DICOM* and *DQCOM*. The logic type affects wiring and control of the sensors; therefore, you must determine the required value in the engineering phase in view of the application.

Special Case: Safety Function STO

The inputs for the safety function STO (inputs *STO_A* and *STO_B*) can only be wired for sinking inputs.

Configurable Inputs and Outputs

Description

This product has digital inputs and outputs that can be configured for specific functional assignments. The inputs and outputs have a defined standard assignment depending on the operating mode. This assignment can be adapted to the requirements of the customer's installation. See Digital Signal Inputs and Digital Signal Outputs, page 169 for information.

Mains Supply

Residual Current Device

Description

Direct current can be introduced in the protective ground conductor of this drive. If a residual current device (RCD / GFCI) or a residual current monitor (RCM) is used for protection against direct or indirect contact, the following specific types must be used:

⚠ WARNING

DIRECT CURRENT CAN BE INTRODUCED INTO THE PROTECTIVE GROUND CONDUCTOR

- Use a Type A Residual Current Device (RCD / GFCI) or a Residual Current Monitor (RCM) for single-phase drives connected to a phase and to the neutral conductor.
- Use a Type B Residual Current Device (RCD / GFCI) or a Residual Current Monitor (RCM) that has approval for use with frequency inverters and is sensitive to all types of current for three-phase devices and for single-phase devices not connected to a phase and the neutral conductor.

Failure to follow these instructions can result in death, serious injury, or equipment damage.

Further conditions for use of a residual current device:

- The drive has an increased leakage current at the moment power is applied. Use a residual current device (RCD / GFCI) or a residual current monitor (RCM) with a response delay.
- High-frequency currents must be filtered.

Common DC Bus

Function Principle

The DC buses of several drives can be connected so that energy can be used efficiently. If one drive decelerates, a different drive connected to the common DC bus can use the generated braking energy. Without a common DC bus, the braking energy would be converted to heat by the braking resistor while the other drive would have to be supplied with energy from mains.

Another advantage of having a common DC bus is that several drives can share one external braking resistor. The number of the individual external braking resistors can be reduced to a single braking resistor if the braking resistor is properly rated.

This and other important information can be found in the Common DC bus Application Note for the drive. If you wish to take advantage of DC bus sharing, you must first consult the Common DC bus Application Note for important safety-related information.

Requirements for Use

The requirements and limit values for parallel connection of multiple drives via the DC bus are described in the Common DC bus Application Note for the drive that can be found on <https://www.se.com>. If there are any issues or questions related to obtaining the Common DC bus Application Note, consult your local Schneider Electric representative.

Mains Reactor

Description

A mains reactor must be used under the following conditions:

- Operation via supply mains with low impedance (short-circuit current of supply mains greater than specified in section *Technical Data*, page 23).
- If the nominal power of the drive is insufficient.
- In the case of operation with supply mains with reactive power compensation systems.
- For improvement of the power factor at the mains input and for reduction of mains harmonics.

A single mains reactor can be used for multiple devices. Use a mains reactor with a properly rated current.

Low-impedance supply mains cause high harmonic currents at the mains input. High harmonic currents result in considerable load on the DC bus capacitors. The load on the DC bus capacitors has a decisive impact on the service life of the devices.

Rating the Braking Resistor

Internal Braking Resistor

Description

The drive is equipped with an internal braking resistor to absorb braking energy.

Braking resistors are required for dynamic applications. During deceleration, the kinetic energy is transformed into electrical energy in the motor. The electrical energy increases the DC bus voltage. The braking resistor is activated when the defined threshold value is exceeded. The braking resistor transforms electrical energy into heat. If highly dynamic deceleration is required, the braking resistor must be well adapted to the system.

An insufficiently rated braking resistor can cause overvoltage on the DC bus. Overvoltage on the DC bus causes the power stage to be disabled. The motor is no longer actively decelerated.

⚠ WARNING

UNINTENDED EQUIPMENT OPERATION

- Verify that the braking resistor has a sufficient rating by performing a test run under maximum load conditions.
- Verify that the parameter settings for the braking resistor are correct.

Failure to follow these instructions can result in death, serious injury, or equipment damage.

External Braking Resistor

Description

An external braking resistor is required for applications in which the motor must be decelerated quickly and the internal braking resistor cannot absorb the excess braking energy.

The temperature of the braking resistor may exceed 250 °C (482 °F) during operation.

⚠ WARNING

HOT SURFACES

- Ensure that it is not possible to make any contact with a hot braking resistor.
- Do not allow flammable or heat-sensitive parts in the immediate vicinity of the braking resistor.
- Verify that the heat dissipation is sufficient by performing a test run under maximum load conditions.

Failure to follow these instructions can result in death, serious injury, or equipment damage.

Monitoring

The drive monitors the power of the braking resistor. The load on the braking resistor can be read out.

The output for the external braking resistor is short-circuit protected. The drive does not monitor for ground faults of the braking resistor.

Selection of the External Braking Resistor

The rating of an external braking resistor depends on the required peak power and continuous power.

The resistance R is derived from the required peak power and the DC bus voltage.

$$R = \frac{U^2}{P_{\max}}$$

R = Resistance in Ω

U = Switching threshold for braking resistor V

P_{\max} = Required peak power in W

If two or more braking resistors are connected to one drive, note the following criteria:

- The total resistance of the connected braking resistors must comply with the approved resistance.
- The braking resistors can be connected in parallel or in series. Only connect braking resistors with identical resistance in parallel in order to evenly distribute the load to the braking resistors.
- The total continuous power of the connected braking resistors must be greater than or equal to the required continuous power.

Use only resistors that are specified as braking resistors. For suitable braking resistors, see *Accessories and Spare Parts*, page 373.

Mounting and Commissioning of an External Braking Resistor

A parameter is used to switch between the internal braking resistor and an external braking resistor.

The external braking resistors listed in the *Accessories and Spare Parts*, page 373 section are shipped with an information sheet that provides details on their installation.

Rating Information

Description

To rate the braking resistor, calculate the proportion contributing to absorbing braking energy.

An external braking resistor is required if the kinetic energy that must be absorbed exceeds the possible total internal energy absorption.

Internal Energy Absorption

Braking energy is absorbed internally by:

- DC bus capacitor E_{var}
- Internal braking resistor E_{i}
- Electrical losses of the drive E_{el}
- Mechanical losses of the drive E_{mech}

Values for the energy absorption E_{var} can be found in section *Capacitor and Braking Resistor*, page 45.

Internal Braking Resistor

Two characteristic values determine the energy absorption of the internal braking resistor.

- The continuous power P_{PR} is the amount of energy that can be continuously absorbed without overloading the braking resistor.
- The maximum energy E_{CR} limits the maximum short-term power that can be absorbed.

If the continuous power was exceeded for a specific time, the braking resistor must remain without load for a corresponding period.

The characteristic values P_{PR} and E_{CR} of the internal braking resistor can be found in section *Capacitor and Braking Resistor*, page 45.

Electrical Losses E_{el}

The electrical losses E_{el} of the drive system can be estimated on the basis of the peak power of the drive. The maximum power dissipation is approximately 10% of the peak power at a typical efficiency of 90%. If the current during deceleration is lower, the power dissipation is reduced accordingly.

Mechanical Losses E_{mech}

The mechanical losses result from friction during operation of the system. Mechanical losses are negligible if the time required by the system to coast to a stop without a driving force is considerably longer than the time required to decelerate the system. The mechanical losses can be calculated from the load torque and the velocity from which the motor is to stop.

Example

Deceleration of a rotary motor with the following data:

- Initial speed of rotation: $n = 4000$ RPM
- Rotor inertia: $J_R = 4$ kgcm²
- Load inertia: $J_L = 6$ kgcm²
- Drive: $E_{var} = 23$ Ws, $E_{CR} = 80$ Ws, $P_{PR} = 10$ W

Calculation of the energy to be absorbed:

$$E_B = \frac{1}{2} J \cdot \left[\frac{2\pi n}{60} \right]^2$$

to $E_B = 88$ Ws. Electrical and mechanical losses are ignored.

In this example, the DC bus capacitors absorb $E_{var} = 23$ Ws (the value depends on the drive type).

The internal braking resistor must absorb the remaining 65 Ws. It can absorb a pulse of $E_{CR} = 80$ Ws. If the load is decelerated once, the internal braking resistor is sufficient.

If the deceleration is repeated cyclically, the continuous power must be taken into account. If the cycle time is longer than the ratio of the energy to be absorbed E_B and the continuous power P_{PR} , the internal braking resistor is sufficient. If the system decelerates more frequently, the internal braking resistor is not sufficient.

In this example, the ratio of E_B/P_{PR} is 8.8 s. An external braking resistor is required if the cycle time is shorter.

Rating the External Braking Resistor

Characteristic curves for rating the braking resistor

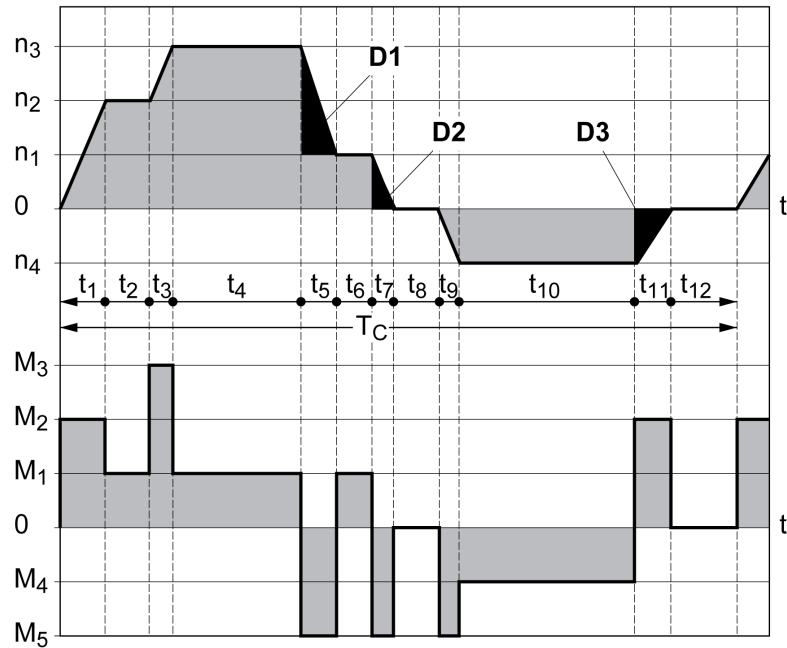

These two characteristics are also used for the rating the motor. The segments of the characteristic curves to be considered are designated by D_i ($D_1 \dots D_3$).

The total inertia J_t must be known for the calculation of the energy at constant deceleration.

$$J_t = J_m + J_c$$

J_m : Motor inertia (with holding brake)

J_c : Load inertia

The energy for each deceleration segment is calculated as follows:

$$E_i = \frac{1}{2} J_t \cdot \omega_i^2 = \frac{1}{2} J_t \cdot \left[\frac{2\pi n_i}{60} \right]^2$$

Calculation for the segments (D_1) ... (D_3):

$$E_1 = \frac{1}{2} J_t \cdot \left[\frac{2\pi}{60} \right]^2 \cdot \left[n_3^2 - n_1^2 \right]$$

$$E_2 = \frac{1}{2} J_t \cdot \left[\frac{2\pi n_1}{60} \right]^2$$

$$E_3 = \frac{1}{2} J_t \cdot \left[\frac{2\pi n_4}{60} \right]^2$$

Units: E_i in Ws (wattseconds), J_t in kgm^2 , ω in rad and n_i in RPM.

See the technical data for the energy absorption E_{var} of the drives (without consideration of a braking resistor).

In the next calculation steps, only consider those segments D_i , whose energy E_i exceeds the energy absorption of the drive. These excess energies E_{Di} must be diverted by means of the braking resistor.

E_{Di} is calculated using the following formula:

$$E_{Di} = E_i - E_{var} \text{ (in Ws)}$$

The continuous power P_c is calculated for each machine cycle:

$$P_c = \frac{\sum E_{Di}}{\text{Cycletime}}$$

Units: P_c in W, E_{Di} in Ws and cycle time T in s

The selection is made in two steps:

- If the following conditions are met, the internal braking resistor is sufficient.
 - The maximum energy during deceleration must be less than the peak energy that the braking resistor can absorb: $(E_{Di}) < (E_{Cr})$.
 - The continuous power of the internal braking resistor must not be exceeded: $(P_c) < (P_{Pr})$.
- If the conditions are not met, you must use an external braking resistor that meets the conditions.

For order data for the external braking resistors, see *Accessories and Spare Parts*, page 373.

Functional Safety

Basics

Functional Safety

Automation and safety engineering are closely related. Engineering, installation and operation of complex automation solutions are simplified by safety-related functions and equipment.

Usually, the safety engineering requirements depend on the application. The level of the requirements results from, among other things, the risk and the hazard potential arising from the specific application and from the applicable standards and regulations.

The goal of designing machines safely is to protect people. The risk associated with machines with electrically controlled drives comes chiefly from moving machine parts and electricity itself.

Only you, the user, machine builder, or system integrator can be aware of all the conditions and factors realized in the design of your application for the machine. Therefore, only you can determine the automation equipment and the related safeties and interlocks which can be properly used, and validate such usage.

▲ WARNING

NON-CONFORMANCE TO SAFETY FUNCTION REQUIREMENTS

- Specify the requirements and/or measures to be implemented in the risk analysis you perform.
- Verify that your safety-related application complies to applicable safety regulations and standards.
- Make certain that appropriate procedures and measures (according to applicable sector standards) have been established to help avoid hazardous situations when operating the machine.
- Use appropriate safety interlocks where personnel and/or equipment hazards exist.
- Validate the overall safety-related function and thoroughly test the application.

Failure to follow these instructions can result in death, serious injury, or equipment damage.

Hazard and Risk Analysis

The standard IEC 61508 "Functional safety of electrical/electronic/programmable electronic safety-related systems" defines the safety-related aspects of systems. Instead of a single functional unit of a safety-related system, the standard treats all elements of a function chain as a unit. These elements must meet the requirements of the specific safety integrity level as a whole.

The standard IEC 61800-5-2 "Adjustable speed electrical power drive systems – Safety requirements – Functional" is a product standard that defines the safety-related requirements regarding drives. Among other things, this standard defines the safety-related functions for drives.

Based on the system configuration and utilization, a hazard and risk analysis must be carried out for the system (for example, according to EN ISO 12100 or EN ISO 13849-1). The results of this analysis must be considered when designing the machine, and subsequently applying safety-related equipment and safety-related functions. The results of your analysis may deviate from any application examples contained in the present or related documentation. For example, additional safety components may be required. In principle, the results from the hazard and risk analysis have priority.

⚠ WARNING

UNINTENDED EQUIPMENT OPERATION

- Perform a hazard and risk analysis to determine the appropriate safety integrity level, and any other safety requirements, for your specific application based on all the applicable standards.
- Ensure that the hazard and risk analysis is conducted and respected according to EN/ISO 12100 during the design of your machine.

Failure to follow these instructions can result in death, serious injury, or equipment damage.

The EN ISO 13849-1 Safety of machinery - Safety-related parts of control systems - Part 1: General Principles for Design describes an iterative process for the selection and design of safety-related parts of controllers to reduce the risk to the machine to a reasonable degree.

To perform risk assessment and risk minimization according to EN ISO 12100, proceed as follows:

1. Defining the boundary of the machine.
2. Identifying risks associated with the machine.
3. Assessing risks.
4. Evaluating risks.
5. Minimizing risks by:
 - The design
 - Protective devices
 - User information (see EN ISO 12100)
6. Designing safety-related controller parts (SRP/CS, Safety-Related Parts of the Control System) in an interactive process.

To design the safety-related controller parts in an interactive process, proceed as follows:

Step	Action
1	Identify necessary safety functions that are executed via SRP/CS (Safety-Related Parts of the Control System).
2	Determine required properties for each safety function.
3	Determine the required performance level PL _r .
4	Identify safety-related parts executing the safety function.
5	Determine the performance level PL of the afore-mentioned safety-related parts.
6	Verify the performance level PL for the safety function (PL ≥ PL _r).
7	Verify that all requirements have been met (validation).

Additional information is available on <https://www.se.com>.

Safety Integrity Level (SIL)

The standard IEC 61508 defines 4 safety integrity levels (Safety Integrity Level (SIL)). Safety integrity level SIL1 is the lowest level, safety integrity level SIL4 is the highest level. The safety integrity level required for a given application is determined on the basis of the hazard potential resulting from the hazard and risk analysis. This is used to decide whether the relevant function chain is to be considered as a safety-related function chain and which hazard potential it must cover.

Average Frequency of a Dangerous Failure per Hour (PFH)

To maintain the function of the safety-related system, the IEC 61508 standard requires various levels of measures for avoiding and controlling faults, depending on the required safety integrity level (Safety Integrity Level (SIL)). All components must be subjected to a probability assessment to evaluate the effectiveness of the measures implemented for controlling faults. This assessment determines the probability of a dangerous failure per hour PFH (Average Frequency of a Dangerous Failure per Hour (PFH)) for a safety-related system. This is the frequency per hour with which a safety-related system fails in a hazardous manner so that it can no longer perform its function correctly. Depending on the SIL, the average frequency of a dangerous failure per hour must not exceed certain values for the entire safety-related system. The individual PFH values of a function chain are added. The result must not exceed the maximum value specified in the standard.

SIL	PFH at high demand or continuous demand
4	$\geq 10^{-9} \dots < 10^{-8}$
3	$\geq 10^{-8} \dots < 10^{-7}$
2	$\geq 10^{-7} \dots < 10^{-6}$
1	$\geq 10^{-6} \dots < 10^{-5}$

Hardware Fault Tolerance (HFT) and Safe Failure Fraction (SFF)

Depending on the safety integrity level (Safety Integrity Level (SIL)) for the safety-related system, the IEC 61508 standard requires a specific hardware fault tolerance (Hardware Fault Tolerance (HFT)) in connection with a specific safe failure fraction (Safe Failure Fraction (SFF)). The hardware fault tolerance is the ability of a safety-related system to execute the required function even if one or more hardware faults are present. The safe failure fraction of a safety-related system is defined as the ratio of the rate of safe failures to the total failure rate of the safety-related system. As per IEC 61508, the maximum achievable safety integrity level of a safety-related system is partly determined by the hardware fault tolerance and the safe failure fraction of the safety-related system.

IEC 61800-5-2 distinguishes two types of subsystems (type A subsystem, type B subsystem). These types are specified on the basis of criteria which the standard defines for the safety-related components.

SFF	HFT type A subsystem			HFT type B subsystem		
	0	1	2	0	1	2
<60 %	SIL1	SIL2	SIL3	—	SIL1	SIL2
60 ... <90 %	SIL2	SIL3	SIL4	SIL1	SIL2	SIL3
90 ... <99 %	SIL3	SIL4	SIL4	SIL2	SIL3	SIL4
≥ 99 %	SIL3	SIL4	SIL4	SIL3	SIL4	SIL4

Fault Avoidance Measures

Systematic errors in the specifications, in the hardware and the software, incorrect usage and maintenance of the safety-related system must be avoided to the maximum degree possible. To meet these requirements, IEC 61508 specifies a number of measures for fault avoidance that must be implemented depending on the required safety integrity level (Safety Integrity Level (SIL)). These measures for fault avoidance must cover the entire life cycle of the safety-related system, i.e. from design to decommissioning of the system.

Data for Maintenance Plan and the Calculations for Functional Safety

The safety function must be tested at regular intervals. The interval depends on the hazard and risk analysis of the total system. The minimum interval is 1 year (high demand mode as per IEC 61508).

Use the following data of the safety function STO for your maintenance plan and for the calculations for functional safety:

Characteristic	Unit	Value
Lifetime of the safety function STO (IEC 61508)	Years	20 See also Lifetime Safety Function STO, page 380.
SFF (IEC 61508) Safe Failure Fraction	%	90
HFT (IEC 61508) Hardware Fault Tolerance Type A subsystem	-	1
Safety integrity level IEC 61508	-	SIL3
Safety integrity level IEC 62061	-	SILCL3
PFH (IEC 61508) Probability of Dangerous Hardware Failure per Hour	1/h (FIT)	$1 \cdot 10^{-9}$ (1)
PL (ISO 13849-1) Performance Level	-	e (category 3)
MTTF _d (ISO 13849-1) Mean Time to Dangerous Failure	-	High (1400 years)
DC (ISO 13849-1) Diagnostic Coverage	%	90

Contact your local Schneider Electric representative for additional data, if required.

Definitions

Integrated Safety-Related Function "Safe Torque Off" STO

The integrated safety-related function STO (IEC 61800-5-2) allows for a category 0 stop as per IEC 60204-1 without external power contactors. It is not necessary to interrupt the supply voltage for a category 0 stop. This reduces the system costs and the response times.

Category 0 Stop (IEC 60204-1)

In stop category 0 (Safe Torque Off, STO), the drive coasts to a stop (provided there are no external forces operating to the contrary). The safety-related function STO is intended to help prevent an unintended start-up, not stop a motor, and therefore corresponds to an unassisted stop in accordance with IEC 60204-1.

In circumstances where external influences are present, the coast down time depends on physical properties of the components used (such as weight, torque, friction, etc.), and additional measures such as external safety-related brakes may be necessary to help prevent any hazard from materializing. That is to say, if this means a hazard to your personnel or equipment, you must take appropriate measures.

▲ WARNING

UNINTENDED EQUIPMENT OPERATION

- Make certain that no hazards can arise for persons or material during the coast down period of the axis/machine.
- Do not enter the zone of operation during the coast down period.
- Ensure that no other persons can access the zone of operation during the coast down period.
- Use appropriate safety interlocks where personnel and/or equipment hazards exist.

Failure to follow these instructions can result in death, serious injury, or equipment damage.

Category 1 Stop (IEC 60204-1)

For stops of category 1 (Safe Stop 1, SS1), you can initiate a controlled stop via the control system, or through the use of specific functional safety-related devices. A Category 1 Stop is a controlled stop with power available to the machine actuators to achieve the stop.

The controlled stop by the control/safety-related system is not safety-relevant, nor monitored, and does not perform as defined in the case of a power outage or if an error is detected. This has to be implemented by means of an external safety-related switching device with safety-related delay.

Function

General

The safety-related function STO integrated into the product can be used to implement an "EMERGENCY STOP" (IEC 60204-1) for category 0 stops. With an additional, approved EMERGENCY STOP safety relay module, it is also possible to implement category 1 stops.

Function Principle

The safety-related function STO is triggered via two redundant signal inputs. The wiring of the two signal inputs must be separate.

The safety-related function STO is triggered if the level at one of the two signal inputs is 0. The power stage is disabled. The motor can no longer generate torque and coasts down without braking. An error of error class 3 is detected.

If, within one second, the level of the other output also becomes 0, the error class remains 3. If, within one second, the level of the other output does not become 0, the error class changes to 4.

Requirements for Using the Safety-Related Function STO

General

The safety-related function STO (Safe Torque Off) does not remove power from the DC bus. The safety-related function STO only removes power to the motor. The DC bus voltage and the mains voltage to the drive are still present.

DANGER

ELECTRIC SHOCK

- Do not use the safety-related function STO for any other purposes than its intended function.
- Use an appropriate switch, that is not part of the circuit of the safety-related function STO, to disconnect the drive from the mains power.

Failure to follow these instructions will result in death or serious injury.

After the safety-related function STO is triggered, the motor can no longer generate torque and coasts down without braking.

WARNING

UNINTENDED EQUIPMENT OPERATION

Install a dedicated, external safety-related brake if coasting does not meet the deceleration requirements of your application.

Failure to follow these instructions can result in death, serious injury, or equipment damage.

Logic Type

The inputs for the safety-related function STO (inputs *STO_A* and *STO_B*) can only be wired for sinking inputs.

Holding Brake and Safety-Related Function STO

When the safety-related function STO is triggered, the power stage is immediately disabled. Applying the holding brake requires a certain amount of time. In the case of vertical axes or external forces acting on the load, you may have to take additional measures to bring the load to a standstill and to keep it at a standstill when the safety-related function STO is used, for example, by using a service brake.

WARNING

FALLING LOAD

Ensure that all loads come to a secure standstill when the safety-related function STO is used.

Failure to follow these instructions can result in death, serious injury, or equipment damage.

If the suspension of hanging / pulling loads is a safety objective for the machine, then you can only achieve this objective by using an appropriate external brake as a safety-related measure.

▲ WARNING**UNINTENDED AXIS MOVEMENT**

- Do not use the internal holding brake as a safety-related measure.
- Only use certified external brakes as safety-related measures.

Failure to follow these instructions can result in death, serious injury, or equipment damage.

NOTE: The drive does not provide its own safety-related output to connect an external brake to use as a safety-related measure.

Unintended Restart**▲ WARNING****UNINTENDED EQUIPMENT OPERATION**

- Verify that your risk assessment covers all potential effects of automatic or unintended enabling of the power stage, for example, after power outage.
- Implement all measures such as control functions, guards, or other safety-related functions, required to reliably protect against all hazards that may result from automatic or unintended enabling of the power stage.
- Verify that a master controller cannot enable the power stage in an unintended way.

Failure to follow these instructions can result in death, serious injury, or equipment damage.

▲ WARNING**UNINTENDED EQUIPMENT OPERATION**

Set the parameter *IO_AutoEnable* to "off" if the automatic enabling of the power stage presents hazards in your application.

Failure to follow these instructions can result in death, serious injury, or equipment damage.

Degree of Protection when the Safety-Related Function STO is Used

You must ensure that conductive substances cannot get into the product (pollution degree 2). Moreover, conductive substances may cause the safety-related function to become inoperative.

▲ WARNING**INOPERABLE SAFETY-RELATED FUNCTION**

Ensure that conductive substances (water, contaminated or impregnated oils, metal shavings, etc.) cannot get into the drive.

Failure to follow these instructions can result in death, serious injury, or equipment damage.

Protected Cable Installation

If short circuits and other wiring errors such as a cross circuit between the signals of the safety-related function STO can be expected in connection with safety-related signals, and if these short circuits and cross circuits are not detected by upstream devices, protected cable installation as per ISO 13849-2 is required.

In the case of an unprotected cable installation, the two signals (both channels) of a safety-related function may be connected to external voltage if a cable is damaged. If the two channels are connected to external voltage, the safety-related function is no longer operative.

ISO 13849-2 describes protected cable installation for cables for safety-related signals. The cables for the safety-related function STO must be protected against external voltage. A shield with ground connection helps to keep external voltage away from the cables for the signals of the safety-related function STO.

Ground loops can cause problems in machines. A shield connected at one end only is sufficient for grounding and does not create a ground loop.

- Use shielded cables for the signals of the safety-related function STO.
- Do not use the cable for the signals of the safety-related function STO for other signals.
- Connect one end of the shield.

Application Examples STO

Example of Category 0 stop

Use without EMERGENCY STOP safety relay module, category 0 stop.

Example of category 0 stop:

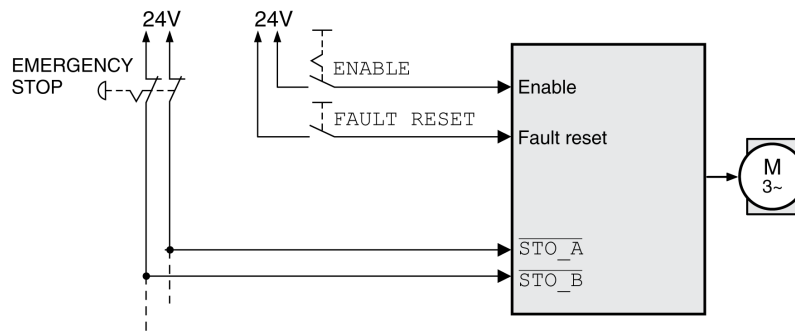

In this example, when an EMERGENCY STOP is activated, it leads to a category 0 stop.

The safety-related function STO is triggered via a simultaneous 0-level at both inputs (time offset of less than 1 s). The power stage is disabled and an error of error class 3 is detected. The motor can no longer generate torque.

If the motor is not already at a standstill when the safety-related function STO is triggered, it decelerates under the salient physical forces (gravity, friction, etc.) active at the time until presumably coasting to a standstill.

If coasting of the motor and its potential load is unsatisfactory as determined by your risk assessment, an external safety-related brake may also be required.

⚠ WARNING
UNINTENDED EQUIPMENT OPERATION
Install a dedicated, external safety-related brake if coasting does not meet the deceleration requirements of your application.
Failure to follow these instructions can result in death, serious injury, or equipment damage.

Refer to section Holding Brake and Safety-Related Function STO, page 76.

Example of Category 1 stop

Use with EMERGENCY STOP safety relay module, category 1 stop.

Example of category 1 stop with external Preventa XPS-AV EMERGENCY STOP safety relay module:

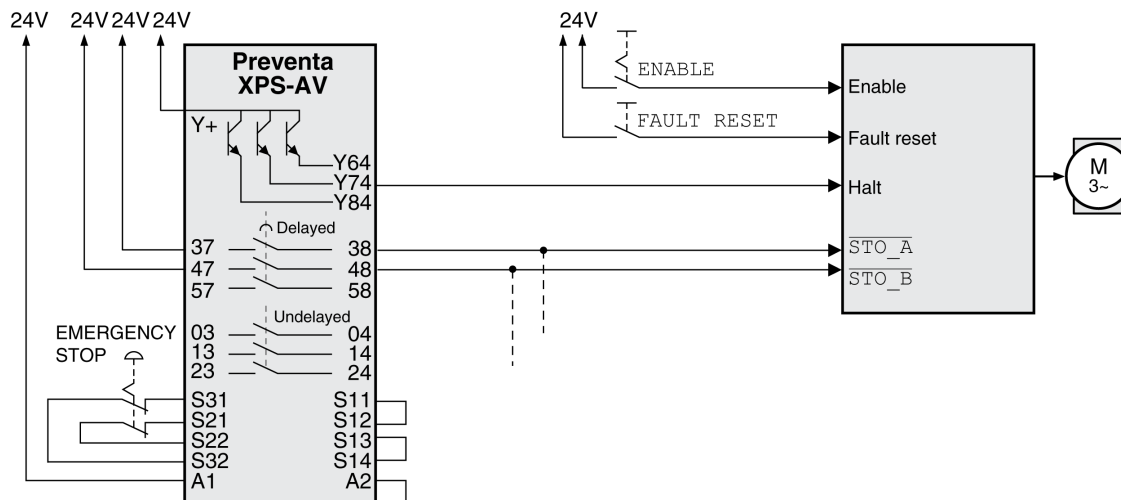

In this example, when an EMERGENCY STOP is activated, it leads to a category 1 stop.

The EMERGENCY STOP safety relay module requests an immediate stop (undelayed) of the drive. After the time delay set in the EMERGENCY STOP safety relay module has elapsed, the EMERGENCY STOP safety relay triggers the safety-related function STO.

The safety-related function STO is triggered via a simultaneous 0-level at both inputs (time offset of less than 1 s). The power stage is disabled and an error of error class 3 is detected. The motor can no longer generate torque.

If coasting of the motor and its potential load is unsatisfactory as determined by your risk assessment, an external safety-related brake may also be required.

⚠ WARNING

UNINTENDED EQUIPMENT OPERATION

Install a dedicated, external safety-related brake if coasting does not meet the deceleration requirements of your application.

Failure to follow these instructions can result in death, serious injury, or equipment damage.

Refer to section Holding Brake and Safety-Related Function STO, page 76.

Installation

Mechanical Installation

Before Mounting

General

An engineering phase is mandatory prior to mechanical and electrical installation. See section Engineering, page 53 for basic information.

DANGER

ELECTRIC SHOCK CAUSED BY INSUFFICIENT GROUNDING

- Verify compliance with all local and national electrical code requirements as well as all other applicable regulations with respect to grounding of the entire drive system.
- Ground the drive system before applying voltage.
- Do not use conduits as protective ground conductors; use a protective ground conductor inside the conduit.
- The cross section of the protective ground conductor must comply with the applicable standards.
- Do not consider cable shields to be protective ground conductors.

Failure to follow these instructions will result in death or serious injury.

DANGER

ELECTRIC SHOCK OR UNINTENDED EQUIPMENT OPERATION

- Keep foreign objects from getting into the product.
- Verify the correct seating of seals and cable entries in order to avoid contamination such as deposits and humidity.

Failure to follow these instructions will result in death or serious injury.

▲ WARNING

LOSS OF CONTROL

- The designer of any control scheme must consider the potential failure modes of control paths and, for certain critical control functions, provide a means to achieve a safe state during and after a path failure. Examples of critical control functions are emergency stop and overtravel stop, power outage and restart.
- Separate or redundant control paths must be provided for critical control functions.
- System control paths may include communication links. Consideration must be given to the implications of unanticipated transmission delays or failures of the link.
- Observe all accident prevention regulations and local safety guidelines.¹
- Each implementation of this equipment must be individually and thoroughly tested for proper operation before being placed into service.

Failure to follow these instructions can result in death, serious injury, or equipment damage.

¹ For additional information, refer to NEMA ICS 1.1 (latest edition), "Safety Guidelines for the Application, Installation, and Maintenance of Solid State Control" and to NEMA ICS 7.1 (latest edition), "Safety Standards for Construction and Guide for Selection, Installation and Operation of Adjustable-Speed Drive Systems" or their equivalent governing your particular location.

Conductive foreign objects, dust or liquids may cause safety-related functions to become inoperative.

▲ WARNING

LOSS OF SAFETY-RELATED FUNCTION CAUSED BY FOREIGN OBJECTS

Protect the system against contamination by conductive substances.

Failure to follow these instructions can result in death, serious injury, or equipment damage.

The metal surfaces of the product may exceed 70 °C (158 °F) during operation.

▲ CAUTION

HOT SURFACES

- Avoid unprotected contact with hot surfaces.
- Do not allow flammable or heat-sensitive parts in the immediate vicinity of hot surfaces.
- Verify that the heat dissipation is sufficient by performing a test run under maximum load conditions.

Failure to follow these instructions can result in injury or equipment damage.

▲ CAUTION

INOPERABLE EQUIPMENT DUE TO INCORRECT MAINS VOLTAGE CONNECTION

- Verify that you use the correct mains voltage; install a transformer, if necessary.
- Do not connect mains voltage to the output terminals (U, V, W).

Failure to follow these instructions can result in injury or equipment damage.

Inspecting the Product

- Verify the product version by means of the Type Code, page 22 on the Nameplate, page 21.
- Prior to mounting, inspect the product for visible damage.

Damaged products may cause electric shock or unintended equipment operation.

⚡⚠ DANGER
<p>ELECTRIC SHOCK OR UNINTENDED EQUIPMENT OPERATION</p> <ul style="list-style-type: none"> • Do not use damaged products. • Keep foreign objects (such as chips, screws or wire clippings) from getting into the product. <p>Failure to follow these instructions will result in death or serious injury.</p>

Contact your local Schneider Electric representative if you detect any damage whatsoever to the products.

For information concerning the mounting of the motor, see the individual user guide for your particular motor.

Mounting the Drive

Attaching a Hazard Label with Safety Instructions

Included in the packaging of the drive are adhesive hazard labels in German, French, Italian, Spanish and Chinese. The English version is affixed to the front of the drive by the factory. If the country to which your final machine or process is to be delivered is other than English speaking:

- Select the label suitable for the target country.
Observe the safety regulations in the target country.
- Attach the label to the front of the drive so that it is clearly visible.

Control Cabinet

The control cabinet (enclosure) must have a sufficient size so that all devices and components can be permanently installed and wired in compliance with the EMC requirements.

The ventilation of the control cabinet must be sufficient to comply with the specified ambient conditions for the devices and components operated in the control cabinet.

Install and operate this equipment in a control cabinet rated for its intended environment and secured by a keyed or tooled locking mechanism.

Mounting Distances, Ventilation

When selecting the position of the device in the control cabinet, note the following:

- Mount the device in a vertical position ($\pm 10^\circ$). This is required for cooling the device.
- Adhere to the minimum installation distances for required cooling. Avoid heat accumulations.
- Do not mount the device close to heat sources.
- Do not mount the device on or near flammable materials.
- The heated airflow from other devices and components must not heat up the air used for cooling the device.

- If the thermal limits are exceeded during operation, the power stage of the drive is disabled (overtemperature).

The connection cables of the devices are routed to the top and to the bottom. The minimum distances must be adhered to for air circulation and cable installation.

Mounting distances and air circulation

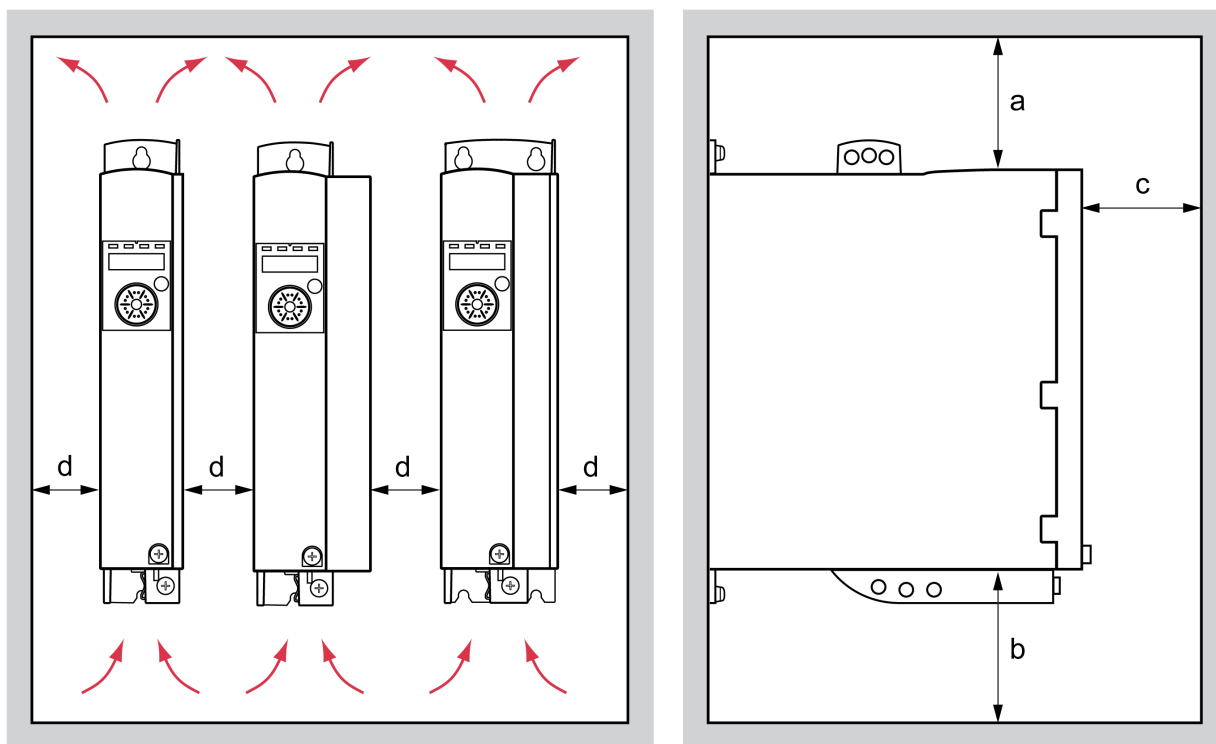

Free space a	mm	≥100
	(in)	(≥3.94)
Free space b	mm	≥100
	(in)	(≥3.94)
Free space c	mm	≥60
	(in)	(≥2.36)
Free space d	mm	≥0
	(in)	(≥0)

Mounting the Device

See section Dimensions, page 25 for the dimensions of the mounting holes.

Painted surfaces may create electrical resistance or isolation. Before mounting the device to a painted mounting plate, remove all paint across a large area of the mounting points.

Electrical Installation

Overview of Procedure

General

DANGER

ELECTRIC SHOCK OR UNINTENDED EQUIPMENT OPERATION

- Keep foreign objects from getting into the product.
- Verify the correct seating of seals and cable entries in order to avoid contamination such as deposits and humidity.

Failure to follow these instructions will result in death or serious injury.

DANGER

ELECTRIC SHOCK CAUSED BY INSUFFICIENT GROUNDING

- Verify compliance with all local and national electrical code requirements as well as all other applicable regulations with respect to grounding of the entire drive system.
- Ground the drive system before applying voltage.
- Do not use conduits as protective ground conductors; use a protective ground conductor inside the conduit.
- The cross section of the protective ground conductor must comply with the applicable standards.
- Do not consider cable shields to be protective ground conductors.

Failure to follow these instructions will result in death or serious injury.

Direct current can be introduced in the protective ground conductor of this drive. If a residual current device (RCD / GFCI) or a residual current monitor (RCM) is used for protection against direct or indirect contact, the following specific types must be used:

WARNING

DIRECT CURRENT CAN BE INTRODUCED INTO THE PROTECTIVE GROUND CONDUCTOR

- Use a Type A Residual Current Device (RCD / GFCI) or a Residual Current Monitor (RCM) for single-phase drives connected to a phase and to the neutral conductor.
- Use a Type B Residual Current Device (RCD / GFCI) or a Residual Current Monitor (RCM) that has approval for use with frequency inverters and is sensitive to all types of current for three-phase devices and for single-phase devices not connected to a phase and the neutral conductor.

Failure to follow these instructions can result in death, serious injury, or equipment damage.

The entire installation procedure must be performed without voltage present.

Connection Overview

Description

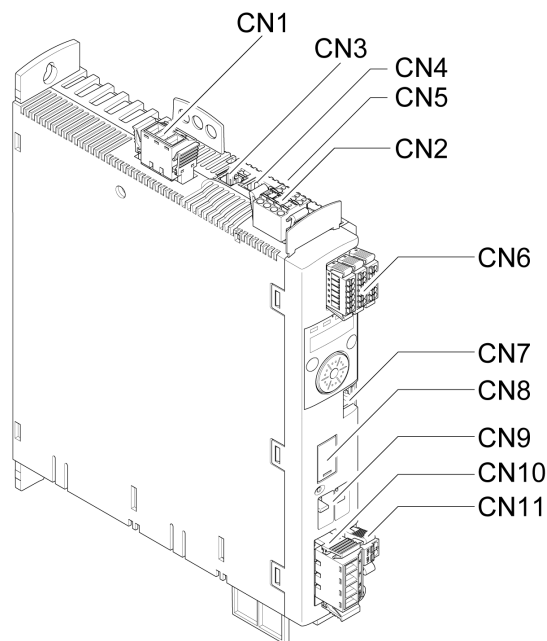

Connection	Assignment
CN1	Power stage supply
CN2	24 Vdc control supply and safety function STO
CN3	Motor encoder (encoder 1)
CN4	PTO (encoder simulation ESIM)
CN5	PTI (A/B signals, P/D signals, CW/CCW signals)
CN6	Analog inputs and digital inputs/outputs
CN7	Modbus (commissioning interface)
CN8	External braking resistor
CN9	DC bus connection for parallel operation
CN10	Motor phases
CN11	Holding brake

Connection Grounding Screw

Description

This product has a leakage current greater than 3.5 mA. If the protective ground connection is interrupted, a hazardous touch current may flow if the housing is touched.

⚡ ⚠ **DANGER**

INSUFFICIENT GROUNDING

- Use a protective ground conductor with at least 10 mm² (AWG 6) or two protective ground conductors with the cross section of the conductors supplying the power terminals.
- Verify compliance with all local and national electrical code requirements as well as all other applicable regulations with respect to grounding of all equipment.
- Ground the drive system before applying voltage.
- Do not use conduits as protective ground conductors; use a protective ground conductor inside the conduit.
- Do not use cable shields as protective ground conductors.

Failure to follow these instructions will result in death or serious injury.

The central grounding screw of the product is located at the bottom of the front side.

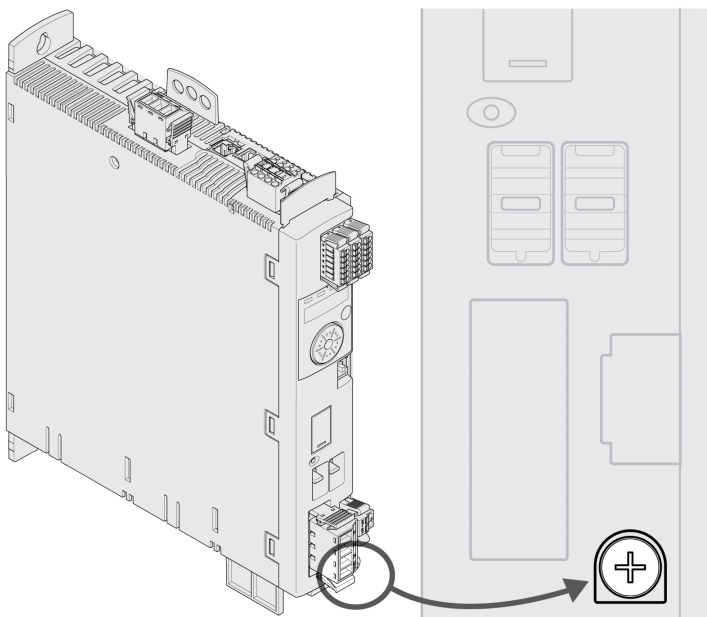

Connect the ground connection of the device to the central grounding point of the system.

Characteristic	Unit	Value
Tightening torque of grounding screw	Nm (lb.in)	3.5 (31)

Connection Motor Phases and Holding Brake (CN10 and CN11)

General

The motor is designed for operation via a drive. Connecting the motor directly to AC voltage will damage the motor and can cause fires and initiate an explosion.

⚠ DANGER
POTENTIAL FOR EXPLOSION
Only connect the motor to a matching, approved drive in the way described in the present documentation.
Failure to follow these instructions will result in death or serious injury.

High voltages may be present at the motor connection. The motor itself generates voltage when the motor shaft is rotated. AC voltage can couple voltage to unused conductors in the motor cable.

⚠⚠ DANGER
ELECTRIC SHOCK
<ul style="list-style-type: none"> • Verify that no voltage is present prior to performing any type of work on the drive system. • Block the motor shaft to prevent rotation prior to performing any type of work on the drive system. • Insulate both ends of unused conductors of the motor cable. • Supplement the motor cable grounding conductor with an additional protective ground conductor to the motor housing if the protective ground conductor of the motor cable is insufficient. • Only touch the motor shaft or the mounted output components if all power has been disconnected. • Verify compliance with all local and national electrical code requirements as well as all other applicable regulations with respect to grounding of all equipment.
Failure to follow these instructions will result in death or serious injury.

Drive systems may perform unintended movements if unapproved combinations of drive and motor are used. Though the connectors for motor connection and encoder connection may match mechanically, this does not imply that the motor is approved for use.

⚠ WARNING
UNINTENDED MOVEMENT
Only use approved combinations of drive and motor.
Failure to follow these instructions can result in death, serious injury, or equipment damage.

See section [Approved Motors](#), page 28 for additional information.

When using pre-assembled cables, route the cables from the motor to the drive starting from the motor. Due to the pre-assembled connectors on the motor side, this direction is often faster and easier.

Cable Specifications

Shield:	Required, both ends grounded
Twisted Pair:	-

PELV:	The wires for the holding brake are PELV-compliant.
Cable composition:	3 wires for motor phases 2 wires for holding brake 1 wire for protective ground (PE)
Maximum cable length:	Depends on the required limit values for conducted interference, see Electromagnetic Emission , page 49.

Note the following information:

- You may only connect the Schneider Electric original motor cable either pre-assembled or open wire.
- The wires for the holding brake must also be connected to the drive at connection CN11 in the case of motors without holding brakes. At the motor end, connect the wires to the appropriate pins for the holding brake; the cable can then be used for motors with or without holding brake. If you do not connect the wires at the motor end, you must isolate each wire individually (inductive voltages).
- Observe the polarity of the holding brake voltage.
- The voltage for the holding brake depends on the 24 Vdc control supply (PELV). Observe the tolerance for the 24 Vdc control supply and the specified voltage for the holding brake, see [24 Vdc Control Supply](#), page 36.
- Use pre-assembled cables to reduce the risk of wiring errors, see [Accessories and Spare Parts](#), page 373.

The optional holding brake of a motor is connected to connection CN11. The integrated holding brake controller releases the holding brake when the power stage is enabled. When the power stage is disabled, the holding brake is re-applied.

Properties of the Connection Terminals CN10

The terminals are approved for stranded conductors and solid conductors. Use wire cable ends (ferrules), if possible.

Characteristic	Unit	Value	
		LXM32-U45, LXM32-U60, LXM32-U90, LXM32-D12, LXM32-D18, LXM32-D30	LXM32-D72
Connection cross section	mm ² (AWG)	0.75 ... 5.3 (18 ... 10)	0.75 ... 10 (18 ... 8)
Tightening torque for terminal screws	Nm (lb.in)	0.68 (6.0)	1.81 (16.0)
Stripping length	mm (in)	6 ... 7 (0.24 ... 0.28)	8 ... 9 (0.31 ... 0.35)

Properties of the Connection Terminals CN11

The terminals are approved for stranded conductors and solid conductors. Use wire cable ends (ferrules), if possible.

Characteristic	Unit	Value
Maximum terminal current	A	1.7
Connection cross section	mm ² (AWG)	0.75 ... 2.5 (18 ... 14)
Stripping length	mm (in)	12 ... 13 (0.47 ... 0.51)

Assembling Cables

Note the dimensions specified when assembling cables.

Steps for assembling the motor cable

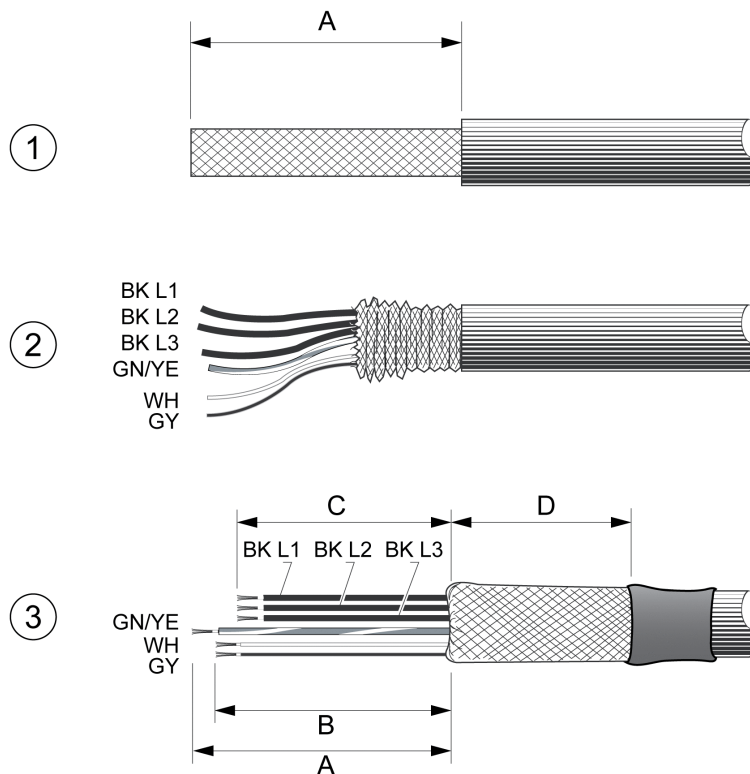

1 Strip the cable jacket, length A.

2 Slide the shielding braid back over the cable jacket.

3 Secure the shielding braid with a heat shrink tube. The shield must have at least length D. Verify that a large surface area of the shielding braid is connected to the EMC shield clamp. Shorten the wires for the holding brake to length B and the three wires for the motor phases to length C. The protective ground conductor has length A. Connect the wires for the holding brake to the drive even in the case of motors without a holding brake (inductive voltage).

Characteristic	Unit	Value
A	mm (in)	140 (5.51)
B	mm (in)	135 (5.32)
C	mm (in)	130 (5.12)
D	mm (in)	50 (1.97)

Observe the maximum permissible connection cross section. Take into account the fact that wire cable ends (ferrules) increase the cross section size.

Monitoring

The drive monitors the motor phases for:

- Short-circuit between the motor phases
- Short-circuit between the motor phases and ground

Short-circuits between the motor phases and the DC bus, the braking resistor or the holding brake wires are not detected.

Wiring Diagram Motor and Holding Brake

Wiring diagram motor with holding brake

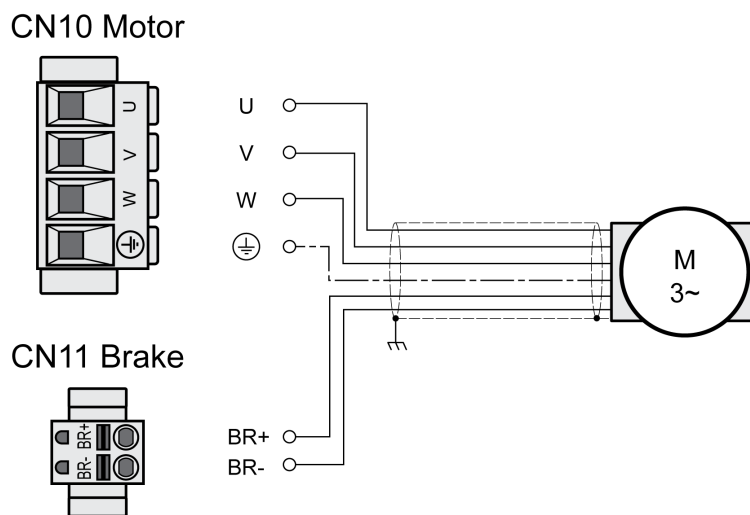

Connection	Meaning	Color
U	Motor phase	Black L1 (BK)
V	Motor phase	Black L2 (BK)
W	Motor phase	Black L3 (BK)
PE	Protective ground conductor	Green/yellow (GN/YE)
BR+	Holding brake +	White (WH) or black 5 (BK)
BR-	Holding brake -	Gray (GR) or black 6 (BK)

Connecting the Motor Cable

- Connect the motor phases and protective ground conductor to CN10. Verify that the connections U, V, W and PE (ground) match at the motor and the drive.
- Note the tightening torque specified for the terminal screws.
- Connect the white wire or the black wire with the label 5 to connection BR+ of CN11.
Connect the gray wire or the black wire with the label 6 to connection BR- of CN11.
- Verify that the connector locks snap in properly.
- Connect the cable shield to the shield clamp (large surface area contact).

Shield clamp motor cable

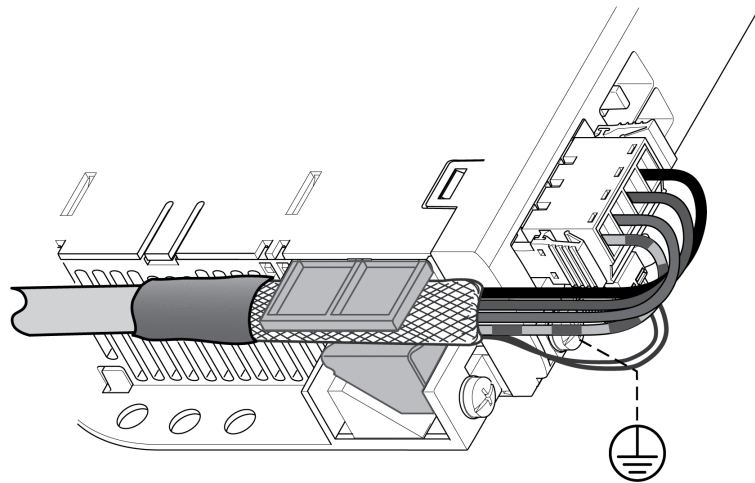

Connection DC Bus (CN9, DC Bus)

General

Incorrect use of the DC bus may permanently damage the drives either immediately or over time.

⚠ WARNING

INOPERABLE SYSTEM COMPONENTS AND LOSS OF CONTROL

Verify that all requirements for using the DC bus are met.

Failure to follow these instructions can result in death, serious injury, or equipment damage.

This and other important information can be found in the "LXM32 - Common DC bus - Application note". If you wish to take advantage of DC bus sharing, you must first read the "LXM32 - Common DC bus - Application note".

Requirements for Use

The requirements and limit values for parallel connection via the DC bus can be found on <https://www.se.com> in the form of an application note. If there are any issues or questions related to obtaining the Common DC bus Application Note, consult your local Schneider Electric representative.

Connection Braking Resistor (CN8, Braking Resistor)

General

An insufficiently rated braking resistor can cause overvoltage on the DC bus. Overvoltage on the DC bus causes the power stage to be disabled. The motor is no longer actively decelerated.

⚠ WARNING

UNINTENDED EQUIPMENT OPERATION

- Verify that the braking resistor has a sufficient rating by performing a test run under maximum load conditions.
- Verify that the parameter settings for the braking resistor are correct.

Failure to follow these instructions can result in death, serious injury, or equipment damage.

Internal Braking Resistor

A braking resistor is integrated in the drive to absorb braking energy. The drive is shipped with the internal braking resistor active.

External Braking Resistor

An external braking resistor is required for applications in which the motor must be decelerated quickly and the internal braking resistor cannot absorb the excess braking energy.

Selection and rating of the external braking resistor are described in section Rating the Braking Resistor, page 66. For suitable braking resistors, see Accessories and Spare Parts, page 373.

Cable Specifications

Shield:	Required, both ends grounded
Twisted Pair:	-
PELV:	-
Cable composition:	Minimum conductor cross section: Same cross section as power stage supply, see Connection Power Stage Supply (CN1), page 94. The conductors must have a sufficiently large cross section so that the fuse at the mains connection can protect the equipment if necessary.
Maximum cable length:	3 m (9.84 ft)

Properties of the Connection Terminals CN8

Characteristic	Unit	Value
Connection cross section	mm ² (AWG)	0.75 ... 3.3 (18 ... 12)
Tightening torque for terminal screws	Nm (lb.in)	0.51 (4.5)
Stripping length	mm (in)	10 ... 11 (0.39 ... 0.43)

The terminals are approved for fine-stranded conductors and solid conductors. Observe the maximum permissible connection cross section. Take into account the fact that wire cable ends (ferrules) increase the cross section size.

If you use wire cable ends (ferrules), use only wire cable ends (ferrules) with collars for these terminals.

Wiring Diagram

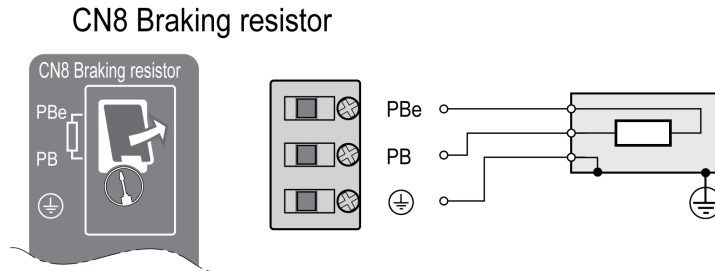

Connecting the External Braking Resistor

- Power off all supply voltages. Observe the safety instructions concerning electrical installation, see Product Related Information, page 13.
- Verify that no voltages are present (safety instructions).
- Remove the cover from the connection.
- Ground the ground connection (PE) of the braking resistor.
- Connect the external braking resistor to the drive. Note the tightening torque specified for the terminal screws.
- Connect the cable shield to the shield connection at the bottom of the drive (large surface area contact).

The parameter *RESint_ext* is used to switch between the internal and an external braking resistor. See section Setting the Braking Resistor Parameters, page 141 for the parameter settings for the braking resistor. Verify correct operation of the braking resistor during commissioning.

Wiring Example

The following graphic shows a functional principle:

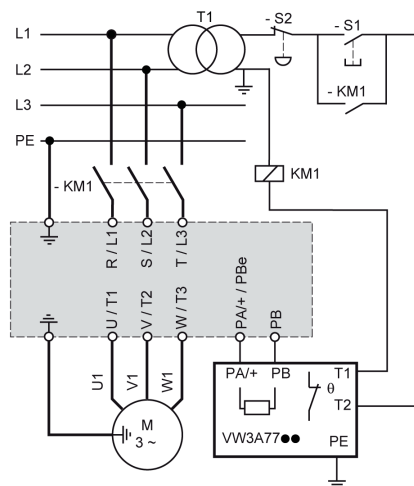



Connection Power Stage Supply (CN1)

General

This product has a leakage current greater than 3.5 mA. If the protective ground connection is interrupted, a hazardous touch current may flow if the housing is touched.

 DANGER
<p>INSUFFICIENT GROUNDING</p> <ul style="list-style-type: none"> • Use a protective ground conductor with at least 10 mm² (AWG 6) or two protective ground conductors with the cross section of the conductors supplying the power terminals. • Verify compliance with all local and national electrical code requirements as well as all other applicable regulations with respect to grounding of all equipment. • Ground the drive system before applying voltage. • Do not use conduits as protective ground conductors; use a protective ground conductor inside the conduit. • Do not use cable shields as protective ground conductors. <p>Failure to follow these instructions will result in death or serious injury.</p>

 WARNING
<p>INSUFFICIENT PROTECTION AGAINST OVERCURRENT</p> <ul style="list-style-type: none"> • Use the external fuses specified in section "Technical data". • Do not connect the product to a supply mains whose short-circuit current rating (SCCR) exceeds the value specified in the section "Technical Data". <p>Failure to follow these instructions can result in death, serious injury, or equipment damage.</p>

 WARNING
<p>INCORRECT MAINS VOLTAGE</p> <p>Verify that the product is approved for the mains voltage before applying power and configuring the product.</p> <p>Failure to follow these instructions can result in death, serious injury, or equipment damage.</p>

The products are intended for industrial use and may only be operated with a permanently installed connection.

Prior to connecting the drive, verify the approved mains types, see Power Stage Data - General, page 27.

Cable Specifications

Shield:	-
Twisted Pair:	-
PELV:	-
Cable composition:	The conductors must have a sufficiently large cross section so that the fuse at the mains connection can protect the equipment if necessary.
Maximum cable length:	-

Properties of Connection Terminals CN1

Characteristic	Unit	Value	
		LXM32-U45, LXM32-U60, LXM32-U90, LXM32-D12, LXM32-D18, LXM32-D30	LXM32-D72
Connection cross section	mm ² (AWG)	0.75 ... 5.3 (18 ... 10)	0.75 ... 10 (18 ... 8)
Tightening torque for terminal screws	Nm (lb.in)	0.68 (6.0)	1.81 (16.0)
Stripping length	mm (in)	6 ... 7 (0.24 ... 0.28)	8 ... 9 (0.31 ... 0.35)

The terminals are approved for stranded conductors and solid conductors. Use wire cable ends (ferrules), if possible.

Prerequisites for Connecting the Power Stage Supply

Note the following information:

- Three-phase drives may only be connected and operated via three phases.
- Use upstream mains fuses.
- If you use an external mains filter, the mains cable must be shielded and grounded at both ends if the length between the external mains filter and the drive exceeds 200 mm (7.87 in).
- See section Conditions for UL 508C and CSA, page 52 for a UL-compliant design.

Power Stage Supply Single-Phase Drive

The illustration shows an overview for wiring the power stage supply for a single-phase drive. The illustration also shows an external mains filter and a mains reactor which are available as accessories.

Overview power stage supply for single-phase drive

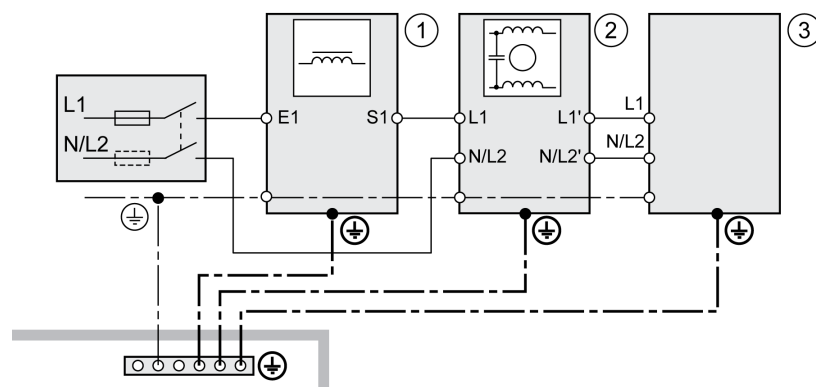

- 1 Mains reactor (accessory)
- 2 External mains filter (accessory)
- 3 Drive

Wiring diagram power stage supply for single-phase drive.

CN1 Mains 115/230 Vac

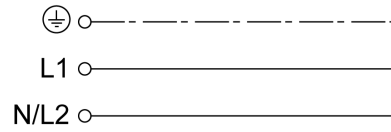
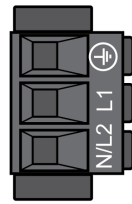

- Verify the type of mains. See section Power Stage Data - General, page 27 for the approved types of mains.
- Connect the mains cable. Note the tightening torque specified for the terminal screws.
- Verify that the connector locks snap in properly.

Power Stage Supply Three-Phase Drive

The illustration shows an overview for wiring the power stage supply for a three-phase drive. The illustration also shows an external mains filter and a mains reactor which are available as accessories.

Wiring diagram, power stage supply for three-phase drive.

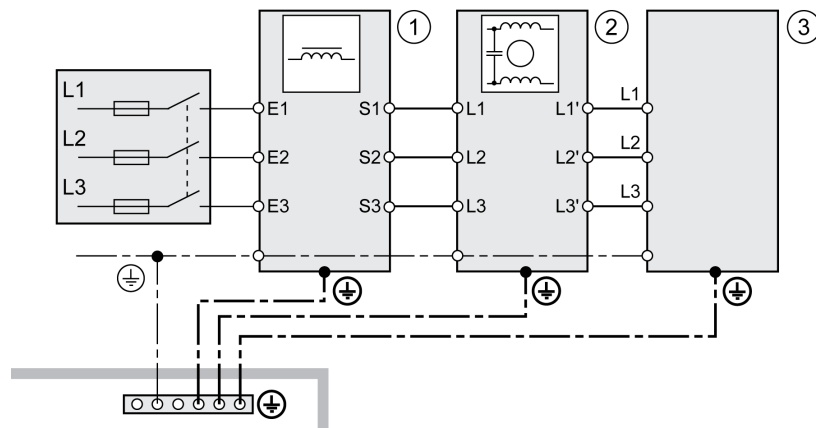

- 1 Mains reactor (accessory)
- 2 External mains filter (accessory)
- 3 Drive

Wiring diagram power stage supply for three-phase drive.

CN1 Mains 208/400/480 Vac

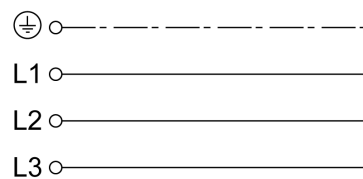

- Verify the type of mains. See section Power Stage Data - General, page 27 for the approved types of mains.
- Connect the mains cable. Note the tightening torque specified for the terminal screws.
- Verify that the connector locks snap in properly.

Connection Motor Encoder (CN3)

Function and Encoder Type

The motor encoder is a Hiperface encoder integrated in the motor. It provides the device with information on the motor position.

Cable Specifications

Shield:	Required, both ends grounded
Twisted Pair:	Required
PELV:	Required
Cable composition:	6 * 0.14 mm ² + 2 * 0.34 mm ² (6 * AWG 24 + 2 * AWG 20)
Maximum cable length:	100 m (328.08 ft)

Use pre-assembled cables to reduce the risk of wiring errors, see Accessories and Spare Parts, page 373.

Wiring Diagram

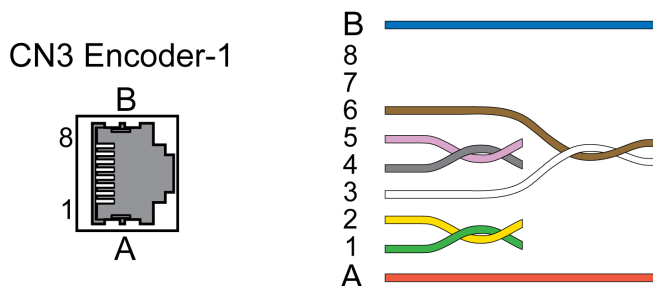

Pin	Signal	Motor, pin	Pair	Meaning	I/O
1	COS+	9	2	Cosine signal	I
2	REFCOS	5	2	Reference for cosine signal	I
3	SIN+	8	3	Sine signal	I
6	REFSIN	4	3	Reference for sine signal	I
4	Data	6	1	Receive data, transmit data	I/O
5	Data	7	1	Receive data and transmit data, inverted	I/O
7 ... 8	-		4	Reserved	
A	ENC+10V_OUT	10	5	Encoder supply	O
B	ENC_0V	11	5	Reference potential for encoder supply	
	SHLD			Shield	

⚠ WARNING
UNINTENDED EQUIPMENT OPERATION
Do not connect any wiring to reserved, unused connections, or to connections designated as No Connection (N.C.).
Failure to follow these instructions can result in death, serious injury, or equipment damage.

Connecting the Motor Encoder

- Verify that wiring, cables and connected interfaces meet the PELV requirements.
- Connect the connector to CN3 Encoder-1.
- Verify that the connector locks snap in properly.

When using pre-assembled cables, route the cables from the motor to the drive starting from the motor. Due to the pre-assembled connectors on the motor side, this direction is often faster and easier.

Connection PTO (CN4, Pulse Train Out)

General

5 V signals are available at the PTO (Pulse Train Out, CN4) output. Depending on parameter *PTO_mode*, these signals are ESIM signals (encoder simulation) or logically fed through PTI input signals (P/D signals, A/B signals, CW/CCW signals). The PTO output signals can be used as PTI input signals for another drive. The signal level corresponds to RS422, see [Output PTO \(CN4\)](#), page 40. The PTO output supplies 5 V signals, even if the PTI input signal is a 24 V signal.

Cable Specifications

Shield:	Required, both ends grounded
Twisted Pair:	Required
PELV:	Required
Cable composition:	8 * 0.14 mm ² (8 * AWG 24)
Maximum cable length:	100 m (328 ft)

Use pre-assembled cables to reduce the risk of wiring errors, see [Accessories and Spare Parts](#), page 373.

Wiring Diagram

Wiring diagram Pulse Train Out (PTO)

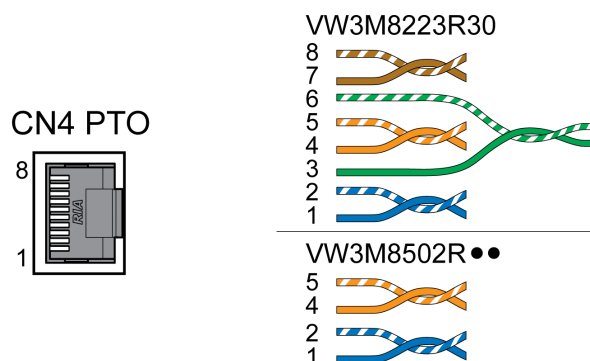

Pin	Signal	Pair	Meaning
1	ESIM_A	2	ESIM channel A
2	ESIM_A	2	ESIM channel A, inverted
4	ESIM_B	1	ESIM channel B
5	ESIM_B	1	ESIM channel B, inverted
3	ESIM_I	3	ESIM index pulse
6	ESIM_I	3	ESIM index pulse, inverted
7	PTO_0V	4	Reference potential
8	PTO_0V	4	Reference potential

PTO: Logically Fed Through PTI Signals

At the PTO output, the PTI input signals can be made available again to control a subsequent drive (daisy chain). Depending on the input signal, the output signal can be of type P/D signal, A/B signal or CW/CCW signal. The PTO output supplies 5 V signals.

Connecting PTO

- Connect the connector to CN4. Verify correct pin assignment.
- Verify that the connector locks snap in properly.

Connection PTI (CN5, Pulse Train In)

General

P/D (pulse/direction), A/B signals or CW/CCW signals can be connected to the PTI connection (Pulse Train In, CN5).

It is possible to connect 5 V signals or 24 V signals, see Input PTI (CN5), page 41. Pin assignments and cables are different.

Incorrect or interfered signals as reference values can cause unintended movements.

⚠ WARNING
<p>UNINTENDED MOVEMENT</p> <ul style="list-style-type: none"> • Use shielded twisted-pair cables. • Do not use signals without push-pull in environments subject to interference. • Use signals with push-pull in the case of cable lengths of more than 3 m (9.84 ft) and limit the frequency to 50 kHz. <p>Failure to follow these instructions can result in death, serious injury, or equipment damage.</p>

Cable Specifications PTI

Shield:	Required, both ends grounded
Twisted Pair:	Required
PELV:	Required

Minimum conductor cross section:	0.14 mm ² (AWG 24)
Maximum cable length:	100 m (328 ft) with RS422 10 m (32.8 ft) with push-pull 1 m (3.28 ft) with open collector

Use pre-assembled cables to reduce the risk of wiring errors, see *Accessories and Spare Parts*, page 373.

Connection Assignment PTI 5 V

Wiring diagram Pulse Train In (PTI) 5 V

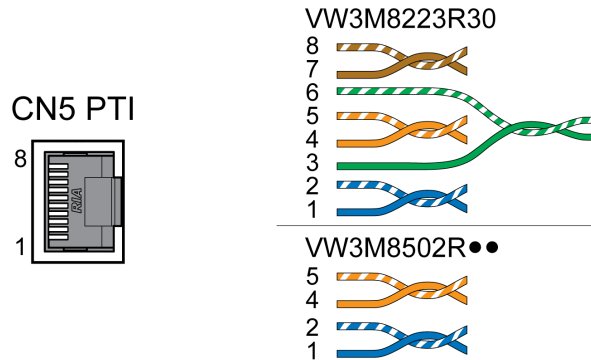

P/D signals 5 V

Pin	Signal	Pair	Meaning
1	<i>PULSE(5V)</i>	2	Pulse 5V
2	<i>PULSE</i>	2	Pulse, inverted
4	<i>DIR(5V)</i>	1	Direction 5V
5	<i>DIR</i>	1	Direction, inverted

A/B signals 5 V

Pin	Signal	Pair	Meaning
1	<i>ENC_A(5V)</i>	2	Encoder channel A 5V
2	<i>ENC_A</i>	2	Encoder channel A, inverted
4	<i>ENC_B(5V)</i>	1	Encoder channel B 5V
5	<i>ENC_B</i>	1	Encoder channel B, inverted

CW/CCW signals 5 V

Pin	Signal	Pair	Meaning
1	<i>CW(5V)</i>	2	Pulse positive 5V
2	<i>CW</i>	2	Pulse positive, inverted
4	<i>CCW(5V)</i>	1	Pulse negative 5V
5	<i>CCW</i>	1	Pulse negative, inverted

⚠ WARNING

UNINTENDED EQUIPMENT OPERATION

Do not connect any wiring to reserved, unused connections, or to connections designated as No Connection (N.C.).

Failure to follow these instructions can result in death, serious injury, or equipment damage.

Connecting Pulse Train IN (PTI) 5 V

- Connect the connector to CN5. Verify correct pin assignment.
- Verify that the connector locks snap in properly.

Connection Assignment PTI 24 V

Note that the wire pairs for 24 V signals require assignments different from those for 5 V signals. Use a cable that complies with the cable specification. Assemble the cable as shown in the illustration below.

Wiring diagram Pulse Train In (PTI) 24 V.

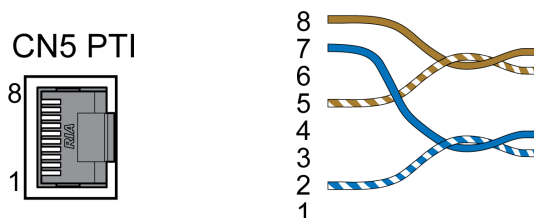

P/D signals 24 V

Pin	Signal	Pair	Meaning
7	PULSE(24V)	A	Pulse 24V
2	PULSE	A	Pulse, inverted
8	DIR(24V)	B	Direction 24V
5	DIR	B	Direction, inverted

A/B signals 24 V

Pin	Signal	Pair	Meaning
7	ENC_A(24V)	A	Encoder channel A 24V
2	ENC_A	A	Encoder channel A, inverted
8	ENC_B(24V)	B	Encoder channel B 24V
5	ENC_B	B	Encoder channel B, inverted

CW/CCW signals 24 V

Pin	Signal	Pair	Meaning
7	CW(24V)	A	Pulse positive 24V
2	CW	A	Pulse positive, inverted
8	CCW(24V)	B	Pulse negative 24V
5	CCW	B	Pulse negative, inverted

⚠ WARNING
UNINTENDED EQUIPMENT OPERATION
Do not connect any wiring to reserved, unused connections, or to connections designated as No Connection (N.C.).
Failure to follow these instructions can result in death, serious injury, or equipment damage.

Connecting Pulse Train In (PTI) 24 V

- Connect the connector to CN5. Verify correct pin assignment.
- Verify that the connector locks snap in properly.

Connection 24 Vdc Control Supply and STO (CN2, DC Supply and STO)

General

The 24 Vdc supply voltage is connected with many exposed signal connections in the drive system.

⚠ WARNING
UNINTENDED EQUIPMENT OPERATION
<ul style="list-style-type: none"> • Use power supply units that meet the PELV (Protective Extra Low Voltage) requirements. • Connect the 0 Vdc outputs of all power supply units to FE (functional earth/functional ground), for example, for the VDC supply voltage and for the 24 Vdc voltage for the safety-related function STO. • Interconnect all 0 Vdc outputs (reference potentials) of all power supply units used for the drive.
Failure to follow these instructions can result in death, serious injury, or equipment damage.

The connection for the 24 Vdc control supply at the product does not have an inrush current limitation. If the voltage is applied by means of switching of contacts, damage to the contacts or contact welding may result.

NOTICE
PERMANENT DAMAGE TO CONTACTS
<ul style="list-style-type: none"> • Switch the power input (primary side) of the power supply unit. • Do not switch the output voltage (secondary side) of the power supply unit.
Failure to follow these instructions can result in equipment damage.

Safety Function STO

Information on the signals of the safety function STO can be found in section Functional Safety, page 71. If the safety function is not required, the inputs STO_A and STO_B must be connected to +24VDC.

Cable Specifications CN2

Shield:	-(1)
Twisted Pair:	-
PELV:	Required
Minimum conductor cross section:	0.75 mm ² (AWG 18)

Maximum cable length:	100 m (328 ft)
(1) See Functional Safety, page 71	

Properties of Connection Terminals CN2

Characteristic	Unit	Value
Maximum terminal current	A	16 ⁽¹⁾
Connection cross section	mm ²	0.5 ... 2.5
	(AWG)	(20 ... 14)
Stripping length	mm	12 ... 13
	(in)	(0.47 ... 0.51)
(1) Note the maximum permissible terminal current when connecting several drives.		

The terminals are approved for stranded conductors and solid conductors. Use wire cable ends (ferrules), if possible.

Permissible Terminal Current of 24 Vdc Control Supply

- Connection CN2, pins 3 and 7 as well as pins 4 and 8 can be used as 24V/0V connections for additional consumers.

In the connector, the following pins are connected: pin 1 to pin 5, pin 2 to pin 6, pin 3 to pin 7 and pin 4 to pin 8.

- The voltage at the holding brake output depends on the 24 Vdc control supply. Note that the current of the holding brake also flows via this terminal.

Wiring Diagram

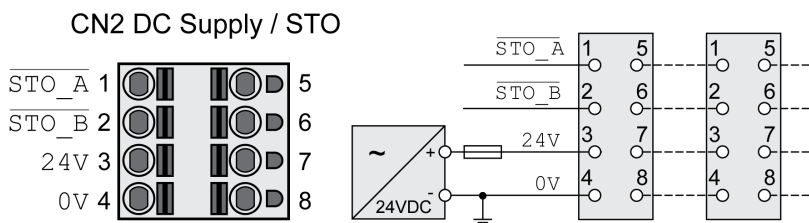

Pin	Signal	Meaning
1, 5	$\overline{STO_A}$	Safety function STO: Dual-channel connection, connection A
2, 6	$\overline{STO_B}$	Safety function STO: Dual-channel connection, connection B
3, 7	24V	24 Vdc control supply
4, 8	0V	Reference potential for 24 Vdc control supply and reference potential for STO

Connecting the Safety Function STO

- Verify that wiring, cables and connected interfaces meet the PELV requirements.
- Connect the safety function in accordance with the specifications in section Functional Safety, page 71.

Connecting the 24 Vdc Control Supply

- Verify that wiring, cables and connected interfaces meet the PELV requirements.
- Route the 24 Vdc control supply from a power supply unit (PELV) to the drive.
- Ground the 0 Vdc output at the power supply unit.
- Note the maximum permissible terminal current when connecting several drives.
- Verify that the connector locks snap in properly at the housing.

Connection Analog Inputs (CN6)

Cable Specifications

Shield:	Required, grounded at the device, other end isolated or grounded via capacitor (for example, 10nF)
PELV:	Required
Cable composition:	2 * 2 * 0.25 mm ² , (2 * 2 * AWG 22)
Maximum cable length:	10 m (32.8 ft)

Properties of Connection Terminals CN6

LXM32*...		
Connection cross section	mm ² (AWG)	0.2 ... 1.0 (24 ... 16)
Stripping length	mm (in)	10 (0.39)

Wiring Diagram

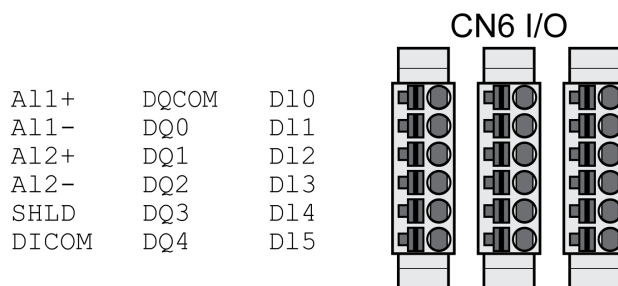

Signal	Meaning
A11+	Analog input 1, ±10 V
A11-	Reference potential to A11+
A12+	Analog input 2, ±10 V
A12-	Reference potential to A12+
SHLD	Shield connection

The connectors are coded. Verify correct assignment when connecting them.

Reference Values and Limits

The ± 10 V scaling of the analog reference values and analog limits can be specified for operation, see [Analog Inputs](#), page 129.

Connecting the Analog Inputs

- Wire the analog inputs at CN6.
- Ground the shield to *SHLD*.
- Verify that the connector locks snap in properly.

Connection Digital Inputs and Outputs (CN6)

General

The device has configurable inputs and configurable outputs. The standard assignment and the configurable assignment depend on the selected operating mode. For more information, see [Digital Signal Inputs and Digital Signal Outputs](#), page 169.

Cable Specifications

Shield:	-
Twisted Pair:	-
PELV:	Required
Cable composition:	0.25 mm ² , (AWG 22)
Maximum cable length:	30 m (98.4 ft)

Properties of Connection Terminals CN6

Characteristic	Unit	Value
Connection cross section	mm ²	0.2 ... 1.0
	(AWG)	(24 ... 16)
Stripping length	mm	10
	(in)	(0.39)

Wiring Diagram

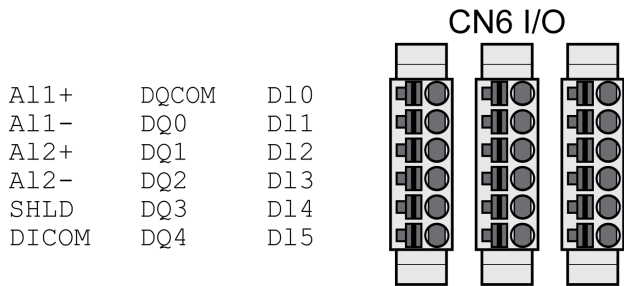

Signal	Meaning
<i>DICOM</i>	Reference potential to <i>D10 ... D15</i>
<i>DQCOM</i>	Reference potential to <i>DQ0 ... DQ4</i>
<i>DQ0</i>	Digital output 0
<i>DQ1</i>	Digital output 1
<i>DQ2</i>	Digital output 2
<i>DQ3</i>	Digital output 3
<i>DQ4</i>	Digital output 4
<i>DI0</i>	Digital input 0
<i>DI1</i>	Digital input 1
<i>DI2</i>	Digital input 2
<i>DI3</i>	Digital input 3
<i>DI4</i>	Digital input 4
<i>DI5</i>	Digital input 5

The connectors are coded. Verify correct assignment when connecting them.

The configuration and the standard assignment of the inputs and outputs are described in section Digital Signal Inputs and Digital Signal Outputs, page 169.

Connecting the Digital Inputs/Outputs

- Wire the digital connections to CN6.
- Ground the shield to *SHLD*.
- Verify that the connector locks snap in properly.

Connection PC with Commissioning Software (CN7)

General

A PC with the commissioning software Lexium DTM Library can be connected for commissioning. The PC is connected via a bidirectional USB/RS485 converter, see Accessories and Spare Parts, page 373.

If the commissioning interface at the product is directly connected to an Ethernet interface at the PC, the PC interface may be damaged and rendered inoperable.

NOTICE
<p>DAMAGE TO PC</p> <ul style="list-style-type: none"> • Use a bidirectional RJ45/USB-A adapter with an RS485/USB converter to connect to a PC. • Do not directly connect an Ethernet interface to the commissioning interface of this product. <p>Failure to follow these instructions can result in equipment damage.</p>

Cable Specifications

Shield:	Required, both ends grounded
Twisted Pair:	Required
PELV:	Required
Cable composition:	8 * 0.25 mm ² (8 * AWG 22)
Maximum cable length:	100 m (328 ft)

Wiring Diagram

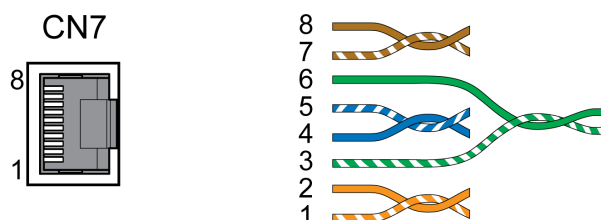

Pin	Signal	Meaning
1 ... 3	-	Reserved
4	MOD_D1	RS485, Bidirectional transmit/receive signal
5	MOD_D0	RS485, Bidirectional transmit/receive signal, inverted
6	-	Reserved
7	MOD+10V_OUT	10 V supply, maximum 100 mA
8	MOD_0V	Reference potential to MOD+10V_OUT

⚠ WARNING
<p>UNINTENDED EQUIPMENT OPERATION</p> <p>Do not connect any wiring to reserved, unused connections, or to connections designated as No Connection (N.C.).</p> <p>Failure to follow these instructions can result in death, serious injury, or equipment damage.</p>

Verify that the connector locks snap in properly.

Verifying Installation

Description

Verify proper installation:

- Verify the mechanical installation of the entire drive system:
 - Does the installation meet the specified distance requirements?
 - Did you tighten all fastening screws with the specified tightening torque?
- Verify the electrical connections and the cabling:
 - Did you connect all protective ground conductors?
 - Do all fuses have the correct rating; are the fuses of the specified type?
 - Did you connect all wires of the cables or insulate them?
 - Did you properly connect and install all cables and connectors?
 - Are the mechanical locks of the connectors correct and effective?
 - Did you properly connect the signal wires?
 - Are the required shield connections EMC-compliant?
 - Did you take all measures for EMC compliance?
 - Does the drive installation conform to all local, regional, and national electrical safety codes for the eventual placement of the equipment?
- Verify that all covers and seals have been properly installed to achieve the required degree of protection.

Commissioning

Overview

General

The safety-related function STO (Safe Torque Off) does not remove power from the DC bus. The safety-related function STO only removes power to the motor. The DC bus voltage and the mains voltage to the drive are still present.

DANGER

ELECTRIC SHOCK

- Do not use the safety-related function STO for any other purposes than its intended function.
- Use an appropriate switch, that is not part of the circuit of the safety-related function STO, to disconnect the drive from the mains power.

Failure to follow these instructions will result in death or serious injury.

External driving forces acting on the motor can cause high currents to be regenerated and supplied back to the drive.

DANGER

FIRE DUE TO EXTERNAL DRIVING FORCES ACTING ON MOTOR

Verify that no external forces can act on the motor in the case of errors of error classes 3 or 4.

Failure to follow these instructions will result in death or serious injury.

Unsuitable parameter values or unsuitable data may trigger unintended movements, trigger signals, damage parts and disable monitoring functions. Some parameter values or data do not become active until after a restart.

WARNING

UNINTENDED EQUIPMENT OPERATION

- Only start the system if there are no persons or obstructions in the zone of operation.
- Do not operate the drive system with undetermined parameter values or data.
- Never modify a parameter value unless you fully understand the parameter and all effects of the modification.
- Restart the drive and verify the saved operational data and/or parameter values after modifications.
- Carefully run tests for all operating states and potential error situations when commissioning, upgrading or otherwise modifying the operation of the drive.
- Verify the functions after replacing the product and also after making modifications to the parameter values and/or other operational data.

Failure to follow these instructions can result in death, serious injury, or equipment damage.

If the power stage is disabled unintentionally, for example as a result of power outage, errors or functions, the motor is no longer decelerated in a controlled way.

⚠ WARNING

UNINTENDED EQUIPMENT OPERATION

Verify that movements without braking effect cannot cause injuries or equipment damage.

Failure to follow these instructions can result in death, serious injury, or equipment damage.

Applying the holding brake while the motor is running will cause excessive wear and degradation of the braking torque.

⚠ WARNING

LOSS OF BRAKING FORCE DUE TO WEAR OR HIGH TEMPERATURE

- Do not use the holding brake as a service brake.
- Do not exceed the maximum number of brake applications and the kinetic energy during braking of moving loads.

Failure to follow these instructions can result in death, serious injury, or equipment damage.

When the product is operated for the first time, there is a risk of unanticipated movements caused by, for example, incorrect wiring or unsuitable parameter settings. Releasing the holding brake can cause an unintended movement, for example, a falling load in the case of vertical axes.

⚠ WARNING

UNINTENDED MOVEMENT

- Verify that there are no persons or obstructions in the zone of operation when operating the system.
- Take appropriate measures to avoid hazards caused by falling or lowering loads or other unintended movements.
- Run initial tests without coupled loads.
- Verify that a functioning emergency stop push-button is within reach of all persons involved in running tests.
- Anticipate movements in unintended directions or oscillations of the motor.

Failure to follow these instructions can result in death, serious injury, or equipment damage.

The product can be accessed via different types of access channels. Simultaneous access via multiple access channels or the use of exclusive access may cause unintended equipment operation.

⚠ WARNING

UNINTENDED EQUIPMENT OPERATION

- Verify that simultaneous access via multiple access channels cannot cause unintended triggering or blocking of commands.
- Verify that the use of exclusive access cannot cause unintended triggering or blocking of commands.
- Verify that the required access channels are available.

Failure to follow these instructions can result in death, serious injury, or equipment damage.

The metal surfaces of the product may exceed 70 °C (158 °F) during operation.

⚠ CAUTION

HOT SURFACES

- Avoid unprotected contact with hot surfaces.
- Do not allow flammable or heat-sensitive parts in the immediate vicinity of hot surfaces.
- Verify that the heat dissipation is sufficient by performing a test run under maximum load conditions.

Failure to follow these instructions can result in injury or equipment damage.

If the drive was not connected to mains for more than 24 months, the capacitors must be restored to their full performance before the motor is started.

NOTICE

REDUCED CAPACITOR PERFORMANCE

Apply mains voltage to the drive for at least one hour before enabling the power stage for the first time in case that the drive has not been under power for a period of 24 months or greater.

Failure to follow these instructions can result in equipment damage.

If the drive is being commissioned for the first time, verify the date of manufacture and run the procedure specified above if the date of manufacture is more than 24 months in the past.

Preparation

Required Components

The following is required for commissioning:

- Commissioning software “Lexium DTM Library”
https://www.se.com/ww/en/download/document/Lexium_DTM_Library/
- Fieldbus converter for the commissioning software for connection via the commissioning interface

Interfaces

The following interfaces can be used for commissioning, parameterization and diagnostics:



①

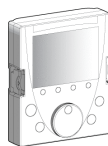

②



③

1 Integrated HMI

2 External graphic display terminal

3 PC with commissioning software “Lexium DTM Library”

Device settings can be duplicated. Stored device settings can be transferred to a device of the same type. Duplicating the device settings can be used if multiple devices are to have the same settings, for example, when devices are replaced.

Commissioning Software

The commissioning software “Lexium DTM Library” has a graphic user interface and is used for commissioning, diagnostics and testing settings.

- Tuning of the control loop parameters via a graphical user interface
- Comprehensive set of diagnostics tools for optimization and maintenance
- Long-term trace for evaluation of the performance
- Testing the input and output signals
- Tracking signals on the screen
- Archiving of device settings and recordings with export function for further processing in other applications

Connecting a PC

A PC with commissioning software can be connected for commissioning. The PC is connected to a bidirectional USB/RS485 converter, see *Accessories and Spare Parts*, page 373.

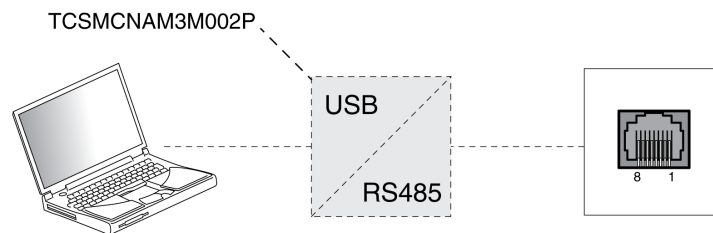

Integrated HMI

Overview of Integrated HMI

Overview

The device allows you to edit parameters, start the operating mode Jog or perform autotuning via the integrated Human-Machine Interface (HMI). Diagnostics information (such as parameter values or error codes) can also be displayed. The individual sections on commissioning and operation include information on whether a function can be carried out via the integrated HMI or whether the commissioning software must be used.

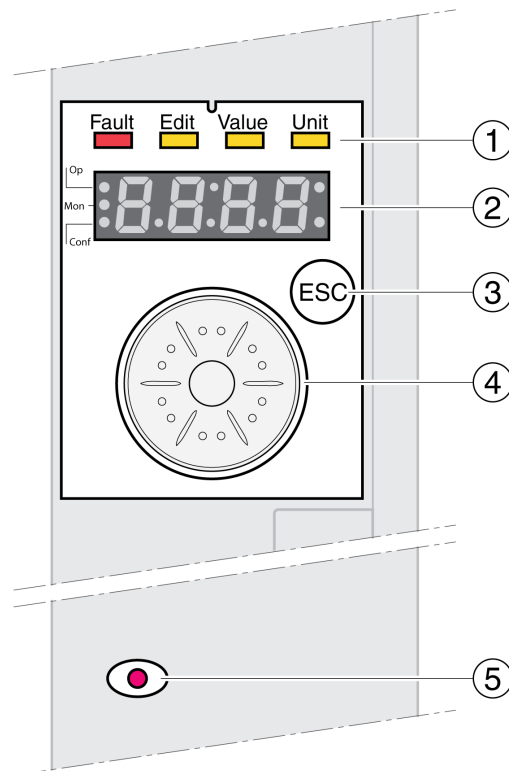

1 Status LEDs

2 7-segment display

3 ESC key

4 Navigation button

5 Red LED on: Voltage present at DC bus

Status LEDs and a 4-digit 7-segment display indicate the device status, menu designation, parameter codes, status codes and error codes. By turning the navigation button, you can select menu levels and parameters and increment or decrement values. To confirm a selection, press the navigation button.

The ESC (Escape) button allows you to exit parameters and menus. If values are displayed, the ESC button lets you return to the last saved value.

Character Set on the HMI

The following table shows the assignment of the characters to the symbols displayed by the 4-digit 7-segment display.

A	B	C	D	E	F	G	H	I	J	K	L	M	N	O	P	Q	R
<i>A</i>	<i>b</i>	<i>c</i>	<i>d</i>	<i>E</i>	<i>F</i>	<i>G</i>	<i>H</i>	<i>I</i>	<i>J</i>	<i>K</i>	<i>L</i>	<i>M</i>	<i>N</i>	<i>O</i>	<i>P</i>	<i>Q</i>	<i>r</i>
S	T	U	V	W	X	Y	Z	1	2	3	4	5	6	7	8	9	0
<i>s</i>	<i>t</i>	<i>u</i>	<i>v</i>	<i>w</i>	<i>x</i>	<i>y</i>	<i>z</i>	<i>1</i>	<i>2</i>	<i>3</i>	<i>4</i>	<i>5</i>	<i>6</i>	<i>7</i>	<i>8</i>	<i>9</i>	<i>0</i>

Indication of the Device Status

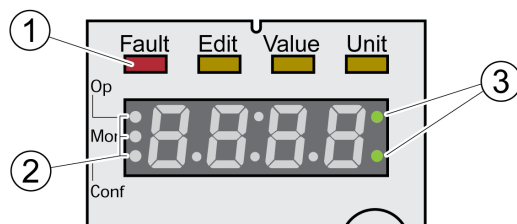

1 Four status LEDs

2 Three status LEDs for identification of the menu levels

3 Flashing dots indicate an error of error class 0

1: Four status LEDs are located above the 7-segment display:

Fault	Edit	Value	Unit	Meaning
Red	-	-	-	Operating state Fault
-	Yellow	Yellow	-	Parameter value can be edited
-	-	Yellow	-	Value of the parameter
-	-	-	Yellow	Unit of the selected parameter

2: Three status LEDs for identification of the menu levels:

LED	Meaning
Op	Operation
Mon	Status information
Conf	Configuration

3: Flashing dots indicate an error of error class 0, for example, if a limit value has been exceeded.

Display of Values

The HMI can directly display values up to 999.

Values greater than 999 are displayed in ranges of 1000. Turn the navigation button to select one of the ranges.

Example: Value 1234567890

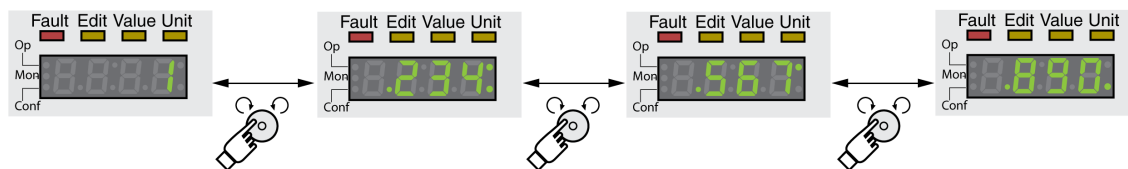

Navigation Button

The navigation button can be turned and pressed. There are two types of pressing: brief pressing (≤ 1 s) and long pressing (≥ 3 s).

Turn the navigation button to do the following:

- Go to the next or previous menu
- Go to the next or previous parameter
- Increment or decrement values
- Switch between ranges in the case of values greater than 999

Briefly **press** the navigation button to do the following:

- Call the selected menu
- Call the selected parameter
- Save the value to the nonvolatile memory

Hold down the navigation button to do the following:

- Display a description of the selected parameter
- Display the unit of the selected parameter

Menu Structure

Description

The integrated HMI is menu-driven. The following illustration shows the top level of the menu structure.

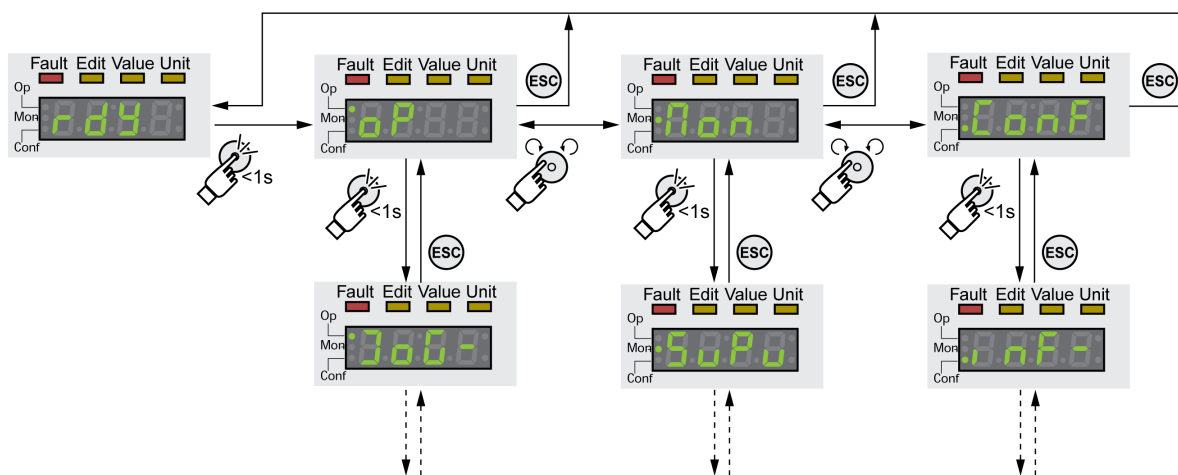

The level below the top level contains the parameters belonging to the respective menu items. To facilitate access, the parameter tables also specify the menu path, for example $oP \rightarrow JOG -$.

Menu Overview

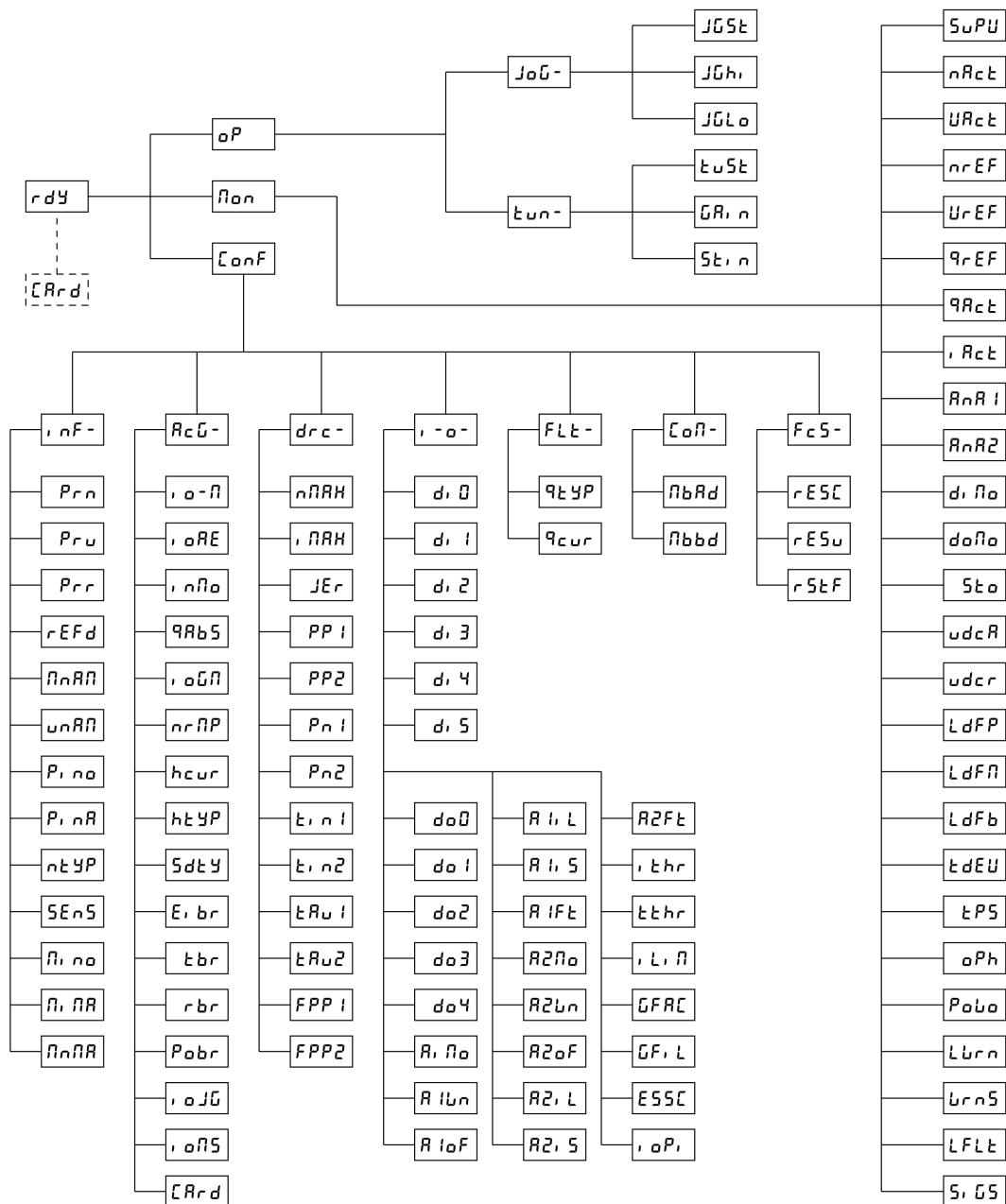

HMI menu oP	Description
oP	Operating mode (Operation)
Jog -	Operating mode Jog
tun -	Autotuning

HMI menu Jog -	Description
Jog -	Operating mode Jog
JGSt	Start operating mode Jog
JGh i	Velocity for fast movement
JGL o	Velocity for slow movement

HMI menu tun -	Description
tun -	Autotuning
tust	Start autotuning

HMI menu <i>тун</i>	Description
<i>ГРН</i>	Global gain factor (affects parameter set 1)
<i>Стн</i>	Direction of movement for Autotuning

HMI menu <i>мон</i>	Description
<i>мон</i>	Monitoring (M onitoring)
<i>СУПУ</i>	HMI display when motor moves
<i>нРск</i>	Actual speed of rotation
<i>ВРск</i>	Actual velocity
<i>нрЕФ</i>	Reference speed of rotation
<i>ВрЕФ</i>	Reference velocity
<i>qrЕФ</i>	Reference motor current (q component, generating torque)
<i>qРск</i>	Actual motor current (q component, generating torque)
<i>iРск</i>	Total motor current
<i>АнА1</i>	Analog 1: Value of input voltage
<i>АнА2</i>	Analog 2: Value of input voltage
<i>дiΠo</i>	Status of digital inputs
<i>доΠo</i>	Status of digital outputs
<i>Sto</i>	Status of the inputs for the safety function STO
<i>υdcR</i>	Voltage at DC bus
<i>υdcr</i>	Degree of utilization of DC bus voltage
<i>LdFP</i>	Load of power stage
<i>LdFΠ</i>	Load of motor
<i>LdFb</i>	Load of braking resistor
<i>тdEV</i>	Device temperature
<i>тPS</i>	Temperature of power stage
<i>oPh</i>	Operating hours counter
<i>Polo</i>	Number of power on cycles
<i>LWrн</i>	Detected error not causing a stop (error class 0)
<i>WrнS</i>	Detected error of error class 0, bit-coded (parameter <i>_WarnLatched</i>)
<i>LFLт</i>	Detected error causing a stop (error classes 1 to 4)
<i>SiGS</i>	Saved status of monitoring signals

HMI menu <i>конF</i>	Description
<i>конF</i>	Configuration (C onfiguration)
<i>инF-</i>	Information/Identification (IN formation / Identification)
<i>РсГ-</i>	Axis configuration (A xis C onfiguration)
<i>дрс-</i>	Device configuration (DR ive C onfiguration)
<i>и-о-</i>	Configurable inputs/outputs (In Out)
<i>FLт-</i>	Indication of detected error
<i>CoΠ-</i>	Communication (COM munication)
<i>FcS-</i>	Restore factory settings (default values) (F actory S ettings)

HMI menu <i>i n F -</i>	Description
<i>i n F -</i>	Information/Identification (IN formation / Identification)
<i>P r n</i>	Firmware number
<i>P r v</i>	Firmware Version
<i>P r r</i>	Firmware Revision
<i>r E F d</i>	Product name
<i>Π n A Π</i>	Type
<i>υ n A Π</i>	User application name
<i>P i n o</i>	Nominal current of power stage
<i>P i n A</i>	Maximum current of power stage
<i>n t Y P</i>	Motor type
<i>S E n S</i>	Encoder type of motor
<i>Π i n o</i>	Nominal current of motor
<i>Π i n A</i>	Maximum motor current
<i>Π n Π A</i>	Maximum permissible speed of rotation/velocity of motor

HMI menu <i>A c G -</i>	Description
<i>A c G -</i>	Axis configuration (Axis Configuration)
<i>i o - Π</i>	Operating Mode
<i>i o A E</i>	Enabling the power stage at PowerOn
<i>i n Π o</i>	Inversion of direction of movement
<i>q A b S</i>	Simulation of absolute position at power cycling
<i>i o G Π</i>	Processing mode for operating mode Electronic Gear
<i>n r Π P</i>	Maximum velocity of the motion profile for velocity
<i>h c u r</i>	Current value for Halt
<i>h t Y P</i>	Halt option code
<i>S d t Y</i>	Behavior for disabling the power stage during movement
<i>E i b r</i>	Selection of internal or external braking resistor
<i>t b r</i>	Maximum permissible activation duration of external braking resistor
<i>r b r</i>	Resistance value of external braking resistor
<i>P o b r</i>	Nominal power of external braking resistor
<i>i o J G</i>	Selection of jog method
<i>i o Π S</i>	Operating mode for signal input function Operating Mode Switch
<i>C A r d</i>	Memory card management

HMI menu <i>d r C -</i>	Description
<i>d r C -</i>	Device configuration (DR ive Configuration)
<i>n Π A X</i>	Velocity limitation
<i>i Π A X</i>	Current limitation
<i>J E r</i>	Jerk limitation of the motion profile for velocity
<i>P P 1</i>	Position controller P gain
<i>P P 2</i>	Position controller P gain
<i>P n 1</i>	Velocity controller P gain
<i>P n 2</i>	Velocity controller P gain
<i>t i n 1</i>	Velocity controller integral action time

HMI menu <i>dr C -</i>	Description
<i>t i n 2</i>	Velocity controller integral action time
<i>t R u 1</i>	Filter time constant of the reference velocity value filter
<i>t R u 2</i>	Filter time constant of the reference velocity value filter
<i>F P P 1</i>	Feed-forward control Velocity
<i>F P P 2</i>	Feed-forward control Velocity

HMI menu <i>i - o -</i>	Description
<i>i - o -</i>	Configurable inputs/outputs (In Out)
<i>d i 0</i>	Function Input DI0
<i>d i 1</i>	Function Input DI1
<i>d i 2</i>	Function Input DI2
<i>d i 3</i>	Function Input DI3
<i>d i 4</i>	Function Input DI4
<i>d i 5</i>	Function Input DI5
<i>d o 0</i>	Function Output DQ0
<i>d o 1</i>	Function Output DQ1
<i>d o 2</i>	Function Output DQ2
<i>d o 3</i>	Function Output DQ3
<i>d o 4</i>	Function Output DQ4
<i>R 1 n o</i>	Analog 1: Type of usage
<i>R 1 W n</i>	Analog 1: Zero voltage window
<i>R 1 o F</i>	Analog 1: Offset voltage
<i>R 1 i L</i>	Analog 1: Limitation of current at 10 V
<i>R 1 i S</i>	Analog 1: Target torque at 10 V in operating mode Profile Torque
<i>a1ft</i>	Analog 1: Filter time constant
<i>R 2 n o</i>	Analog 2: Type of usage
<i>R 2 W n</i>	Analog 2: Zero voltage window
<i>R 2 o F</i>	Analog 2: Offset voltage
<i>R 2 i L</i>	Analog 2: Limitation of current at 10 V
<i>R 2 i S</i>	Analog 2: Target torque at 10 V in operating mode Profile Torque
<i>A2ft</i>	Analog 2: Filter time constant
<i>i t h r</i>	Monitoring of current threshold
<i>t t h r</i>	Monitoring of time window
<i>i L i n</i>	Current limitation via input
<i>G F R c</i>	Selection of special gear ratios
<i>G F i L</i>	Activation of jerk limitation
<i>E S S c</i>	Encoder Simulation Resolution
<i>i o P i</i>	Selection of type of reference value signal for PTI interface

HMI menu <i>F L E -</i>	Description
<i>F L E -</i>	Indication of detected error
<i>q t y P</i>	Quick Stop option code
<i>q c u r</i>	Current value for Quick Stop

HMI menu <i>C o M -</i>	Description
<i>C o M -</i>	Communication (COM munication)
<i>M b A d</i>	Modbus address
<i>M b B d</i>	Modbus baud rate

HMI menu <i>F c S -</i>	Description
<i>F c S -</i>	Restore factory settings (default values) (Factory Settings)
<i>r E S c</i>	Reset control loop parameters
<i>r E S u</i>	Resetting the user parameters
<i>r S t F</i>	Restore factory settings (default values)

Setting Parameters

Displaying and Setting Parameters

The figure below shows an example of displaying a parameter (second level) and entering or selecting a parameter value (third level).

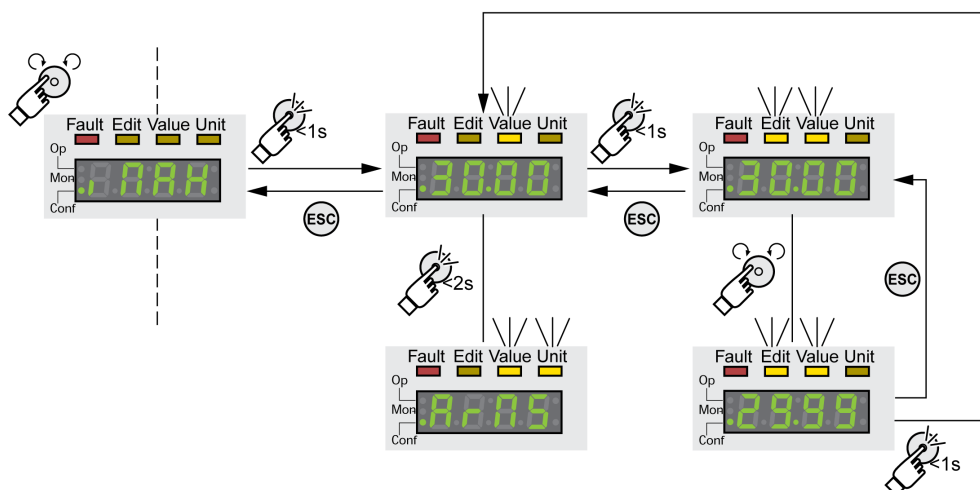

- Go to the parameter *iMax* (iMax).
- Press the navigation button for a longer period of time to display a parameter description.
The parameter description is displayed in the form of horizontally scrolling text.
- Briefly press the navigation button to display the value of the selected parameter.
The LED Value illuminates and the parameter value is displayed.
- Press the navigation button for a longer period of time to display the unit of the parameter value.
As long as the navigation button is held down, the status LEDs Value and Unit illuminate. The unit of the parameter value is displayed. Once you release the navigation button, the parameter value is displayed again.
- Press the navigation button to modify the value of the parameter.
The status LEDs Edit and Value illuminate and the parameter value is displayed.
- Turn the navigation button to modify the value of the parameter. The increments and the limit value for each parameter are pre-defined.
- Briefly press the navigation button to save the modified parameter value.

If you do not want to save the modified parameter value, press the ESC button to cancel. The display returns to the original value of the parameter.

The displayed modified value of the parameter flashes once and is written to the nonvolatile memory.

- Press ESC to return to the menu

Information to be Displayed During Motor Movements

By default, the 7-segment display displays the operating state during motor movements.

You can select the type of information to be displayed during motor movements via the menu item *P00 / SUPV*:

- *STATE* displays the operating state (default)
- *VEL* displays the actual velocity of the motor
- *TOR* displays the actual torque of the motor

The modified value of the parameter is only taken into account at motor standstill.

External Graphic Display Terminal

Display and Controls

Overview

The external graphic display terminal is designed only for commissioning drives.

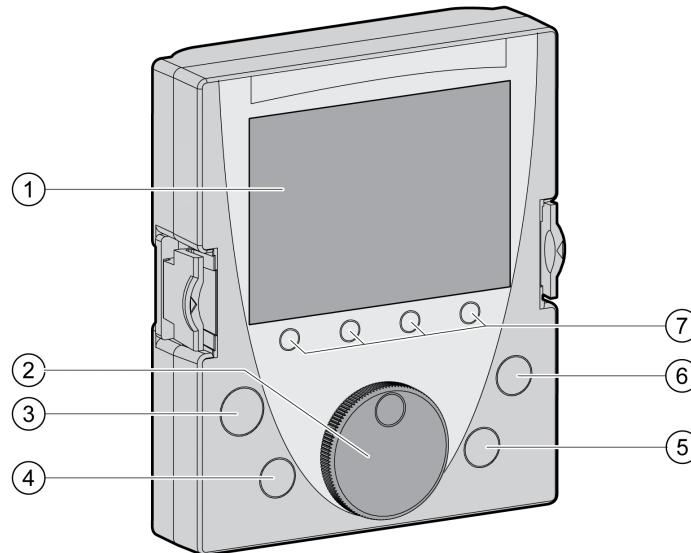

- 1 Display field
- 2 Navigation button
- 3 STOP/RESET key
- 4 RUN key
- 5 FWD/REV key
- 6 ESC key
- 7 Function keys F1 ... F4

Depending on the firmware version of the external graphic display terminal, the information may be represented differently. Use the most up-to-date firmware version.

Display Field (1)

The display is subdivided into 5 areas.

Display of the graphic display terminal (example shows English language)

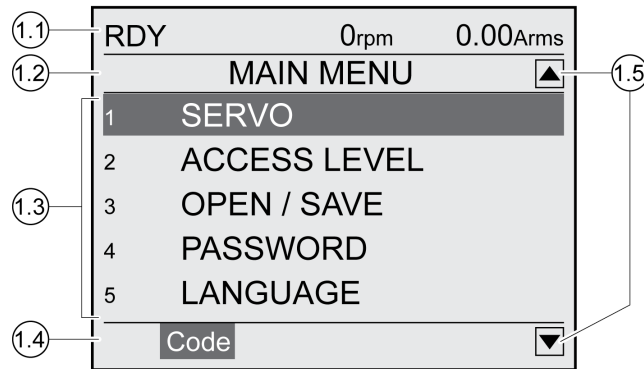

1.1 Status information of the drive

1.2 Menu bar

1.3 Data field

1.4 Function bar

1.5 Navigation

Status Information of the Drive (1.1)

This line displays the operating state, the actual velocity and the actual current of the motor. If an error has been detected, the error code is displayed.

Menu Bar (1.2)

The menu bar displays the name of the menu.

Data Field (1.3)

The following information can be displayed and values entered in the data field:

- Submenus
- Operating Mode
- Parameters and parameter values
- State of movement
- Error messages

Function Bar (1.4)

The function bar displays the name of the function that is triggered when you press the corresponding function key. Example: Pressing the F1 function key displays the "Code". If you press F1, the HMI name of the displayed parameter is shown.

Navigation (1.5)

Arrows indicate that additional information is available that can be displayed by scrolling.

Navigation Button (2)

By turning the navigation button, you can select menu levels and parameters and increment or decrement values. To confirm a selection, press the navigation button.

Key STOP/RESET (3)

The key STOP/RESET terminates a movement by means of a Quick Stop.

Key RUN (4)

The key RUN allows you to start a movement.

Key FWD/REV (5)

The key FWD/REV allows you to reverse the direction of movement.

Key ESC (6)

The ESC (Escape) button allows you to exit parameters and menus or cancel a movement. If values are displayed, the ESC key lets you return to the last saved value.

Function Keys F1 ... F4 (7)

The function bar displays the name of the function triggered when the corresponding function key is pressed.

Connecting the External Graphic Display Terminal to LXM32

Description

The external graphic display terminal is an accessory for the drive, see [Accessories and Spare Parts, page 373](#). The external graphic display terminal is connected to CN7 (commissioning interface). Only use the cable shipped with the external graphic display terminal to connect it. If the external graphic display terminal is connected to LXM32, the integrated HMI is deactivated. The integrated HMI shows *d* , *5* *P* (Display).

Using the External Graphic Display Terminal

Example

The following example shows how to use the external graphic display terminal.

Example 'Setting the Language'

In this example, you set the desired language for the external graphic display terminal. The installation of the drive must have been completed and the 24 Vdc control supply voltage must be on.

- Go to the main menu.
- Rotate the navigation button until item 5 (LANGUAGE) is highlighted.
- Press the navigation button to confirm the selection.

The menu bar shows the selected function 5 (LANGUAGE). The data field displays the selected value, in this case the selected language.

- Press the navigation button to change the value.

The menu bar displays the selected function "Language". The supported languages are shown in the data field.

- Turn the navigation button to select the desired language.
The currently active language is highlighted by a check.
- Press the navigation button to confirm the selected value.

The menu bar displays the selected function "Language". The selected language is shown in the data field.

- Press ESC to return to the main menu.

The main menu is displayed in the selected language.

Commissioning Procedure

Powering on the Drive for the First Time

Automatic Reading of the Motor Data Record

When the drive is powered on and if an encoder is connected to CN3, the drive automatically reads the electronic nameplate from the Hiperface encoder. The data record is verified and written to the nonvolatile memory.

The data record contains technical information on the motor such as nominal torque and peak torque, nominal current, nominal velocity and number of pole pairs. The data record cannot be modified by the user.

Preparation

If the drive is not to be commissioned exclusively via the HMI, a PC with the commissioning software must be connected.

Powering On the Drive

- Verify that the power stage supply and the 24 Vdc control supply are powered off.
- Power on the 24 Vdc control supply.

The drive goes through an initialization routine. The segments of the 7-segment display and the status LEDs illuminate.

If a memory card is in the slot of the drive, the message `CRd` is displayed by the 7-segment display for a short period of time. This indicates that a memory card has been detected. If the message `CRd` is permanently displayed by the 7-segment display, there are differences between the content of the memory card and the parameter values stored in the drive. See section [Memory Card](#), page 157 for additional information.

Restarting the Drive

Depending on the settings of the parameters, a restart of the drive may be required for the modifications to become effective.

- If the HMI shows `r d Y` the drive is ready for operation.
- If the HMI shows `n r d Y` a restart of the drive is required. After the restart, the drive is ready for operation.

Further Steps

- Attach a label to the drive that contains information for servicing, for example, parameter settings.
- Make the settings described below for commissioning.

NOTE: For more information on the presentation of parameters and a list of all operational parameters of the drive, see [Parameters](#), page 298.

Setting Limit Values

Setting Limit Values

Suitable limit values must be determined and calculated on the basis of the system and motor data. As long as the motor is operated without loads, the default settings do not need to be changed.

Current Limitation

The maximum motor current can be set with the parameter *CTRL_I_max*.

The maximum current for the "Quick Stop" function can be limited with the parameter *LIM_I_maxQSTP* and for the "Halt" function with the parameter *LIM_I_maxHalt*.

- Use the parameter *CTRL_I_max* to set the maximum motor current.
- Use the parameter *LIM_I_maxQSTP* to set the maximum motor current for the "Quick Stop" function.
- Use the parameter *LIM_I_maxHalt* to set the maximum motor current for the "Halt" function.

The motor can be decelerated via a deceleration ramp or the maximum current for the functions "Quick Stop" and "Halt".

The device limits the maximum permissible current on the basis of the motor data and the device data. Even if the value entered for the maximum current in the parameter *CTRL_I_max* is too high, the value is limited.

Parameter name HMI menu HMI name	Description	Unit Minimum value Factory setting Maximum value	Data type R/W Persistent Expert	Parameter address via fieldbus
<i>CTRL_I_max</i> <i>CONF → drc -</i> <i>imax</i>	<p>Current limitation.</p> <p>During operation, the current limit is one of the following values (whichever is lowest):</p> <ul style="list-style-type: none"> - <i>CTRL_I_max</i> - <i>M_I_max</i> - <i>PS_I_max</i> <p>- Current limitation via analog input</p> <p>- Current limitation via digital input</p> <p>Limitations caused by I2t monitoring are also taken into account.</p> <p>Default: <i>PS_I_max</i> at 8 kHz PWM frequency and 230/480 V mains voltage</p> <p>In increments of 0.01 A_{rms}.</p> <p>Modified settings become active immediately.</p>	<p>A_{rms}</p> <p>0.00</p> <p>-</p> <p>463.00</p>	<p>UINT16</p> <p>R/W</p> <p>per.</p> <p>-</p>	Modbus 4376
<i>LIM_I_maxQSTP</i> <i>CONF → FLT -</i> <i>qcur</i>	<p>Current for Quick Stop.</p> <p>This value is only limited by the minimum/maximum value range (no limitation of this value by motor/power stage).</p> <p>In the case of a Quick Stop, the current limit (<i>I_max_act</i>) is one of the following values (whichever is lowest):</p> <ul style="list-style-type: none"> - <i>LIM_I_maxQSTP</i> - <i>M_I_max</i> - <i>PS_I_max</i> <p>Further current limitations caused by I2t monitoring are also taken into account during a Quick Stop.</p> <p>Default: <i>PS_I_max</i> at 8 kHz PWM frequency and 230/480 V mains voltage</p> <p>In increments of 0.01 A_{rms}.</p> <p>Modified settings become active immediately.</p>	<p>A_{rms}</p> <p>-</p> <p>-</p> <p>-</p>	<p>UINT16</p> <p>R/W</p> <p>per.</p> <p>-</p>	Modbus 4378
<i>LIM_I_maxHalt</i> <i>CONF → HLG -</i> <i>hcur</i>	<p>Current for Halt.</p> <p>This value is only limited by the minimum/maximum value range (no limitation of this value by motor/power stage).</p> <p>In the case of a Halt, the current limit (<i>I_max_act</i>) is one of the following values (whichever is lowest):</p> <ul style="list-style-type: none"> - <i>LIM_I_maxHalt</i> - <i>M_I_max</i> - <i>PS_I_max</i> <p>Further current limitations caused by I2t monitoring are also taken into account during a Halt.</p> <p>Default: <i>PS_I_max</i> at 8 kHz PWM frequency and 230/480 V mains voltage</p> <p>In increments of 0.01 A_{rms}.</p> <p>Modified settings become active immediately.</p>	<p>A_{rms}</p> <p>-</p> <p>-</p> <p>-</p>	<p>UINT16</p> <p>R/W</p> <p>per.</p> <p>-</p>	Modbus 4380

Velocity Limitation

The parameter *CTRL_v_max* can be used to limit the maximum velocity.

NOTE: Values for positions, velocities, acceleration and deceleration are specified in the following user-defined unit:

- *usr_p* for positions
- *usr_v* for velocities
- *usr_a* for acceleration and deceleration

Parameter name HMI menu HMI name	Description	Unit Minimum value Factory setting Maximum value	Data type R/W Persistent Expert	Parameter address via fieldbus
<i>CTRL_v_max</i> <i>Ctrl_v_max</i> <i>Ctrl_v_max</i>	Velocity limitation. During operation, the velocity limit is one of the following values (whichever is lowest): - <i>CTRL_v_max</i> - <i>M_n_max</i> - Velocity limitation via analog input - Velocity limitation via digital input Modified settings become active immediately.	<i>usr_v</i> 1 13200 2147483647	UINT32 R/W per. -	Modbus 4384

Analog Inputs

Overview

The two analog inputs are referred to as *A11* and *A12*. The following descriptions use the notation *A11* (*A12*) if there are no functional differences between the two inputs.

Analog input voltages between -10 Vdc and +10 Vdc can be read via the analog inputs. The current voltage value at *A11+* (*A12+*) can be read with the parameter *_A11_act* (*_A12_act*).

- Power off the power stage supply.
- Power on the controller supply.
- Apply a voltage in the range from ± 10 Vdc to the analog input *A11* (*A12*).
- Verify the applied voltage with the parameter *_A11_act* (*_A12_act*).

Parameter name HMI menu HMI name	Description	Unit Minimum value Factory setting Maximum value	Data type R/W Persistent Expert	Parameter address via fieldbus
<i>_A11_act</i> <i>A11</i> <i>A11</i>	Analog 1: Value of input voltage.	mV -10000 - 10000	INT16 R/- - -	Modbus 2306
<i>_A12_act</i> <i>A12</i> <i>A12</i>	Analog 2: Value of input voltage.	mV -10000 - 10000	INT16 R/- - -	Modbus 2314

Offset and Zero Voltage Window

The parameter *AI1_offset* (*AI2_offset*) can be used to define an offset and the parameter *AI1_win* (*AI2_win*) to define a zero voltage window for the input voltage at *AI1* (*AI2*).

This corrected input voltage is the voltage value for the operating modes Profile Torque and Profile Velocity as well as the read value of the parameter *AI1_act* (*AI1_act*).

Parameter name HMI menu HMI name	Description	Unit Minimum value Factory setting Maximum value	Data type R/W Persistent Expert	Parameter address via fieldbus
<i>AI1_offset</i> <i>C o n F → 1 - o -</i> <i>R 1 o F</i>	Analog 1: Offset voltage. The analog input AI1 is corrected/offset by the offset value. If you have defined a zero voltage window, this window is effective in the zero pass range of the corrected analog input AI1. Modified settings become active immediately.	mV -5000 0 5000	INT16 R/W per. -	Modbus 2326
<i>AI2_offset</i> <i>C o n F → 1 - o -</i> <i>R 2 o F</i>	Analog 2: Offset voltage. The analog input AI2 is corrected/offset by the offset value. If you have defined a zero voltage window, this window is effective in the zero pass range of the corrected analog input AI2. Modified settings become active immediately.	mV -5000 0 5000	INT16 R/W per. -	Modbus 2328
<i>AI1_win</i> <i>C o n F → 1 - o -</i> <i>R 1 W n</i>	Analog 1: Zero voltage window. Threshold value up to which an input voltage value is treated as 0 V. Example: Value 20, this means a range from -20 ... +20 mV is treated as 0 mV. Modified settings become active immediately.	mV 0 0 1000	UINT16 R/W per. -	Modbus 2322
<i>AI2_win</i> <i>C o n F → 1 - o -</i> <i>R 2 W n</i>	Analog 2: Zero voltage window. Threshold value up to which an input voltage value is treated as 0 V. Example: Value 20, this means a range from -20 ... +20 mV is treated as 0 mV. Modified settings become active immediately.	mV 0 0 1000	UINT16 R/W per. -	Modbus 2324

Offset and zero voltage window

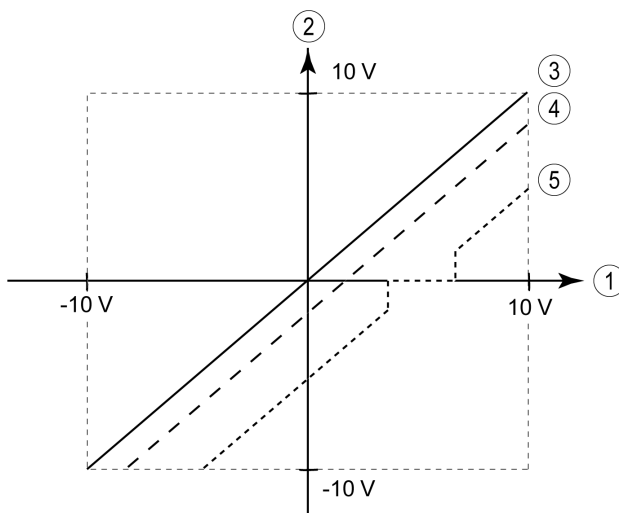

- 1 Input voltage at A/1 (A/2)
- 2 Voltage value for operating modes Profile Torque and Profile Velocity as well as read value of the parameter A/1_act (A/2_act)
- 3 Input voltage without processing
- 4 Input voltage with offset
- 5 Input voltage with offset and zero voltage window

Digital Inputs and Outputs

General

The device has configurable inputs and configurable outputs. See section Digital Signal Inputs and Digital Signal Outputs, page 169 for additional information.

The signal states of the digital inputs and digital outputs can be displayed on the HMI.

Integrated HMI

The signal states can be displayed on the integrated HMI, but they cannot be modified.



Inputs (parameter *_IO_DI_act*):

Open the menu item - *non* → *d, no*.

The digital inputs are displayed in a bit-coded way.

Bit	Signal
0	D/0
1	D/1

Bit	Signal
2	DI2
3	DI3
4	DI4
5	DI5
6 ... 7	-

The parameter `_IO_DI_act` does not display the states of the inputs of the safety function STO. Use the parameter `_IO_STO_act` to visualize the states of the inputs of the safety function STO.

Outputs (parameter `_IO_DQ_act`):

Open the menu item - `П о н → д о П о`.

The digital outputs are displayed in a bit-coded way.

Bit	Signal
0	DQ0
1	DQ1
2	DQ2
3	DQ3
4	DQ4
5 ... 7	-

Verifying the Signals of the Limit Switches

General

The use of limit switches can help protect against some hazards (for example, collision with mechanical stop caused by incorrect reference values).

▲ WARNING

LOSS OF CONTROL

- Ensure that limit switches are installed as determined by your risk assessment.
- Verify correct connection of the limit switches.
- Verify that the limit switches are sufficiently distant from the mechanical end to allow an adequate stopping distance.
- Verify correct parameterization and function of the limit switches.

Failure to follow these instructions can result in death, serious injury, or equipment damage.

- Install and configure the limit switches in such a way that no movements are made beyond the range defined by the limit switches.
- Trigger the limit switches manually.

If an error message is indicated, the limit switches were triggered.

Parameters can be used to release the limit switches and to set them up as normally closed contacts or normally open contacts, see [Limit Switches](#), page 252.

Verifying the Safety Function STO

Operation with Safety Function STO

If you want to use the safety function STO, carry out the following steps:

- To help avoid unintended restart after restoration of power, the parameter *IO_AutoEnable* must be set to "off". Verify that the parameter *IO_AutoEnable* is set to "off".

HMI: *c o n F → R c G → i o R E*.

Power off the power stage supply and the 24 Vdc control supply:

- Verify that the signal wires at the inputs (*STO_A*) and (*STO_B*) are isolated from each other. The two signal wires must not be electrically connected.

Power on the power stage supply and the 24 Vdc control supply:

- Enable the power stage without starting a motor movement.
- Trigger the safety function STO.

If the power stage is now disabled and the error message 1300 is indicated, the safety function STO was triggered.

If a different error message is indicated, the safety function STO was not triggered.

- Document all tests of the safety function in your acceptance protocol.

Operation without Safety Function STO

If you do not want to use the safety function STO:

- Verify that the inputs *STO_A* and *STO_B* are connected to +24VDC.

Holding Brake (Option)

Holding Brake

The holding brake in the motor has the task of holding the motor position when the power stage is disabled. The holding brake is not a safety function and not a service brake.

▲ WARNING

UNINTENDED AXIS MOVEMENT

- Do not use the internal holding brake as a safety-related measure.
- Only use certified external brakes as safety-related measures.

Failure to follow these instructions can result in death, serious injury, or equipment damage.

Releasing the Holding Brake

When the power stage is enabled, current is applied to the motor. When current is applied to the motor, the holding brake is automatically released.

Releasing the holding brake requires a certain amount of time. This time is contained in the electronic nameplate of the motor. Transition to the operating state **6** Operation Enabled is only possible after this time delay has elapsed.

An additional time delay can be set via parameters, see *Additional Time Delay for Releasing the Holding Brake*, page 134.

Applying the Holding Brake

When the power stage is disabled, the holding brake is automatically applied.

However, applying the holding brake requires a certain amount of time. This time is contained in the electronic nameplate of the motor. Current remains to be applied to the motor during this time delay.

See section *Functional Safety*, page 71 for additional information on the behavior of the holding brake when the safety function STO is triggered.

An additional time delay can be set via parameters, see *Additional Time Delay for Applying the Holding Brake*, page 134.

Additional Time Delay for Releasing the Holding Brake

An additional time delay can be set via the parameter *BRK_AddT_release*.

Transition to the operating state **6** Operation Enabled is only possible after the entire time delay has elapsed.

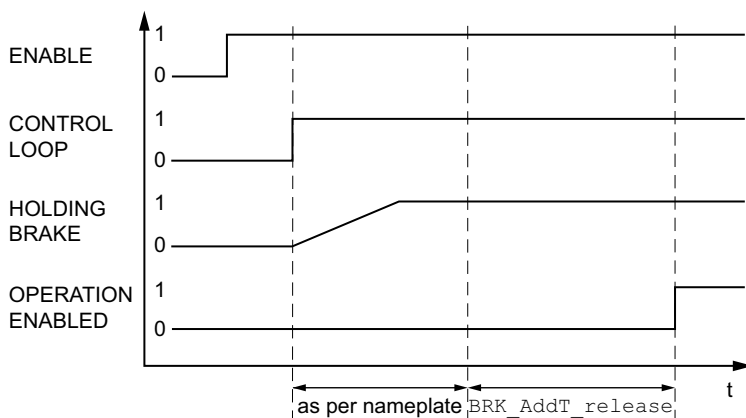

Parameter name	Description	Unit	Data type	Parameter address via fieldbus
HMI menu		Minimum value	R/W	
HMI name		Factory setting	Persistent	
		Maximum value	Expert	
<i>BRK_AddT_release</i>	<p>Additional time delay for releasing the holding brake.</p> <p>The overall time delay for releasing the holding brake is the time delay from the electronic nameplate of the motor and the additional time delay in this parameter.</p> <p>Setting can only be modified if power stage is disabled.</p> <p>Modified settings become active the next time the power stage is enabled.</p>	<p>ms</p> <p>0</p> <p>0</p> <p>400</p>	<p>INT16</p> <p>R/W</p> <p>per.</p> <p>-</p>	Modbus 1294

Additional Time Delay for Applying the Holding Brake

An additional time delay can be set via the parameter *BRK_AddT_apply*.

Current continues to be applied to the motor until the entire time delay has passed.

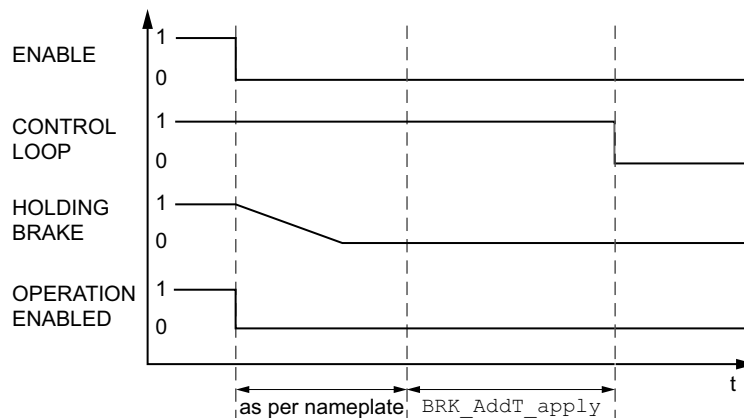

Parameter name HMI menu HMI name	Description	Unit Minimum value Factory setting Maximum value	Data type R/W Persistent Expert	Parameter address via fieldbus
<i>BRK_AddT_apply</i>	<p>Additional time delay for applying the holding brake.</p> <p>The overall time delay for applying the holding brake is the time delay from the electronic nameplate of the motor and the additional time delay in this parameter.</p> <p>Setting can only be modified if power stage is disabled.</p> <p>Modified settings become active the next time the power stage is enabled.</p>	<p>ms</p> <p>0</p> <p>0</p> <p>1000</p>	<p>INT16</p> <p>R/W</p> <p>per.</p> <p>-</p>	Modbus 1296

Verifying the Function of the Holding Brake

The device is in the operating state **4** Ready To Switch On.

Step	Action
1	<p>Start the operating mode Jog (HMI: $\square P \rightarrow J o g \rightarrow J G S t$).</p> <p>The power stage is enabled and the holding brake released. The HMI displays $J G -$.</p>
2	<p>If the holding brake has been released, hold down the navigation button. Then press ESC.</p> <p>As long as the navigation button is held down, the motor moves. When you press ESC, the holding brake is applied again and the power stage is disabled.</p>
3	<p>If the holding brake is not released, press ESC.</p> <p>When you press ESC, the power stage is disabled.</p>
4	Verify the wiring if the behavior of the holding brake is not correct.

Releasing the Holding Brake Manually

Mechanical adjustments may require you to manually rotate the motor shaft.

Manual release of the holding brake is only possible in the operating states **3** Switch On Disabled, **4** Ready To Switch On or **9** Fault.

When the product is operated for the first time, there is a risk of unanticipated movements caused by, for example, incorrect wiring or unsuitable parameter settings. Releasing the holding brake can cause an unintended movement, for example, a falling load in the case of vertical axes.

▲ WARNING

UNINTENDED MOVEMENT

- Verify that there are no persons or obstructions in the zone of operation when operating the system.
- Take appropriate measures to avoid hazards caused by falling or lowering loads or other unintended movements.
- Run initial tests without coupled loads.
- Verify that a functioning emergency stop push-button is within reach of all persons involved in running tests.
- Anticipate movements in unintended directions or oscillations of the motor.

Failure to follow these instructions can result in death, serious injury, or equipment damage.

As of firmware version \geq V01.12, you can manually release the holding brake.

Applying the Holding Brake Manually

For testing the holding brake, you may want to manually apply the holding brake.

You can only apply the holding brake manually when the motor is at a standstill.

If you enable the power stage after the holding brake has been applied manually, the holding brake remains applied.

Manual application of the holding brake has priority over automatic and manual release of the holding brake.

If a movement is started after the holding brake has been applied manually, this can cause wear.

NOTICE

BRAKE WEAR AND LOSS OF BRAKING TORQUE

- Verify that the generated motor torque is not greater than the holding torque of the holding brake if you have applied the holding brake manually.
- Only apply the holding brake manually for the purpose of testing the holding brake.

Failure to follow these instructions can result in equipment damage.

As of firmware version \geq V01.20, you can manually apply the holding brake.

Releasing the Holding Brake Manually via a Signal Input

In order to release the holding brake via a signal input, you must first parameterize the signal input function "Release Holding Brake", see [Digital Signal Inputs and Digital Signal Outputs](#), page 169.

Verifying the Direction of Movement

Definition of Direction of Movement

In the case of a rotary motors, direction of movement is defined in accordance with IEC 61800-7-204: Positive direction is when the motor shaft rotates clockwise as you look at the end of the protruding motor shaft.

It is important to maintain the IEC 61800-7-204 directional standard within your application because many motion-related function blocks, programming conventions, and, safety-related and conventional devices expect this underlying assumption within their logic and operational methodologies.

▲ WARNING

UNINTENDED MOVEMENT CAUSED BY INTERCHANGED MOTOR PHASES

Do not interchange the motor phases.

Failure to follow these instructions can result in death, serious injury, or equipment damage.

If your application requires an inversion of the direction of movement, you can parameterize the direction of movement.

The direction of movement can be verified by starting a movement.

Verifying the Direction of Movement

Power supply has been powered on.

- Start the operating mode Jog. (HMI: $\square P \rightarrow J \square G \rightarrow J G S E$)

The HMI displays $J G -$.

Movement in positive direction:

- Press the navigation button and hold it down.
A movement is made in positive direction.

Movement in negative direction:

- Turn the navigation button until the HMI displays $- J G$.
- Press the navigation button and hold it down.
A movement is made in negative direction.

Changing the Direction of Movement

You can invert the direction of movement.

- Inversion of direction of movement is off:
Movements are made in positive direction with positive target values.
- Inversion of direction of movement is on:
Movements are made in positive direction with negative target values.

The parameter *InvertDirOfMove* allows you to invert the direction of movement.

Parameter name	Description	Unit	Data type	Parameter address via fieldbus
HMI menu		Minimum value	R/W	
HMI name		Factory setting	Persistent	
		Maximum value	Expert	
<i>InvertDirOfMove</i> <i>CONF → RLG -</i> <i>inno</i>	<p>Inversion of direction of movement.</p> <p>0 / Inversion Off / o F F: Inversion of direction of movement is off</p> <p>1 / Inversion On / o n: Inversion of direction of movement is on</p> <p>The limit switch which is reached with a movement in positive direction must be connected to the positive limit switch input and vice versa.</p> <p>Setting can only be modified if power stage is disabled.</p> <p>Modified settings become active the next time the product is powered on.</p>	- 0 0 1	<p>UINT16</p> <p>R/W</p> <p>per.</p> <p>-</p>	Modbus 1560

Setting Parameters for Encoder

General

When starting up, the device reads the absolute position of the motor from the encoder. The absolute position can be read with the parameter *_p_absENC*.

NOTE: Values for positions, velocities, acceleration and deceleration are specified in the following user-defined unit:

- *usr_p* for positions
- *usr_v* for velocities
- *usr_a* for acceleration and deceleration

Parameter name	Description	Unit	Data type	Parameter address via fieldbus
HMI menu		Minimum value	R/W	
HMI name		Factory setting	Persistent	
		Maximum value	Expert	
<i>_p_absENC</i> <i>non</i> <i>PRnu</i>	<p>Absolute position with reference to the encoder range.</p> <p>This value corresponds to the modulo position of the absolute encoder range.</p>	<i>usr_p</i> - - -	<p>UINT32</p> <p>R/-</p> <p>-</p> <p>-</p>	Modbus 7710

Working Range of the Encoder

The working range of the singleturn encoder is 131072 increments per turn.

The working range of the multiturn encoder is 4096 turns with 131072 increments per turn.

Underrun of Absolute Position

If a motor performs a movement from 0 into negative direction, there is an underrun of the absolute position of the encoder. However, the actual position keeps counting forward and delivers a negative position value. After a power cycle, the actual position no longer corresponds to the negative position value, but to the absolute position of the encoder.

The following options are available to adjust the absolute position of the encoder:

- Adjustment of the absolute position

- Shifting the working range

Adjustment of the Absolute Position

When the motor is at a standstill, the new absolute position of the motor can be set to the current mechanical motor position the with the parameter *ENC1_adjustment*.

Adjusting the absolute position also shifts the position of the index pulse.

Procedure:

Set the absolute position at the negative mechanical limit to a position value greater than 0. This way, the movements remain within the continuous range of the encoder.

Parameter name HMI menu HMI name	Description	Unit Minimum value Factory setting Maximum value	Data type R/W Persistent Expert	Parameter address via fieldbus
<i>ENC1_adjustment</i>	<p>Adjustment of absolute position of encoder 1.</p> <p>The value range depends on the encoder type.</p> <p>Singleturn encoder: 0 ... x-1</p> <p>Multiturn encoder: 0 ... (4096*x)-1</p> <p>Singleturn encoder (shifted with parameter <i>ShiftEncWorkRang</i>): -(x/2) ... (x/2)-1</p> <p>Multiturn encoder (shifted with parameter <i>ShiftEncWorkRang</i>): -(2048*x) ... (2048*x)-1</p> <p>Definition of 'x': Maximum position for one encoder turn in user-defined units. This value is 16384 with the default scaling.</p> <p>If processing is to be performed with inversion of the direction of movement, this must be set before the encoder position is adjusted.</p> <p>After the write access, a wait time of at least 1 second is required before the drive can be powered off.</p> <p>Modified settings become active the next time the product is powered on.</p>	usr_p - - -	INT32 R/W - -	Modbus 1324

Shifting the Working Range

The parameter *ShiftEncWorkRang* lets you shift the working range.

The working range without shift comprises:

Singleturn encoder	0 ... 131071 increments
Multiturn encoder	0 ... 4095 revolutions

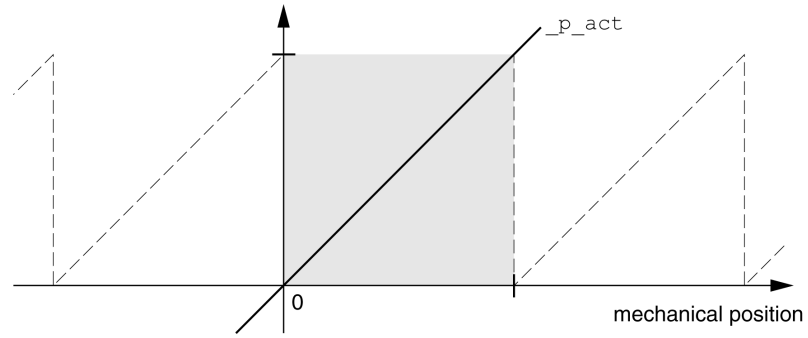

The working range with shift comprises:

Singleturn encoder	-65536 ... 65535 increments
Multiturn encoder	-2048 ... 2047 revolutions

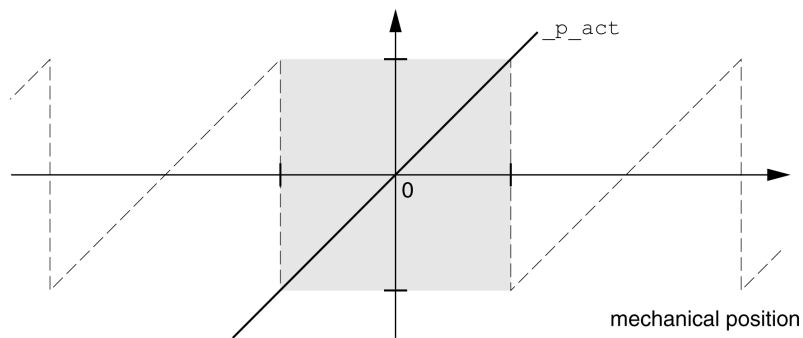

Parameter name	Description	Unit	Data type	Parameter address via fieldbus
HMI menu		Minimum value	R/W	
HMI name		Factory setting	Persistent	
		Maximum value	Expert	
<i>ShiftEncWorkRang</i>	Shifting of the encoder working range. 0 / Off: Shifting off 1 / On: Shifting on After activating the shifting function, the position range of a multiturn encoder is shifted by one half of the range. Example for the position range of a multiturn encoder with 4096 revolutions: Value 0: Position values are between 0 ... 4096 revolutions. Value 1: Position values are between -2048 ... 2048 revolutions. Modified settings become active the next time the product is powered on.	- 0 0 1	UINT16 R/W per. -	Modbus 1346

Setting the Braking Resistor Parameters

Description

An insufficiently rated braking resistor can cause overvoltage on the DC bus. Overvoltage on the DC bus causes the power stage to be disabled. The motor is no longer actively decelerated.

⚠ WARNING

UNINTENDED EQUIPMENT OPERATION

- Verify that the braking resistor has a sufficient rating by performing a test run under maximum load conditions.
- Verify that the parameter settings for the braking resistor are correct.

Failure to follow these instructions can result in death, serious injury, or equipment damage.

The temperature of the braking resistor may exceed 250 °C (482 °F) during operation.

⚠ WARNING

HOT SURFACES

- Ensure that it is not possible to make any contact with a hot braking resistor.
- Do not allow flammable or heat-sensitive parts in the immediate vicinity of the braking resistor.
- Verify that the heat dissipation is sufficient by performing a test run under maximum load conditions.

Failure to follow these instructions can result in death, serious injury, or equipment damage.

If you use an external braking resistor, perform the following steps:

- Set the parameter *RESint_ext* to "External Braking Resistor".
- Set the parameters *RESext_P*, *RESext_R* and *RESext_ton*.

The maximum value of *RESext_P* and the minimum value of *RESext_R* depend on the power stage, see Data for External Braking Resistor, page 46.

See section Rating the Braking Resistor, page 66 for additional information.

If the regenerated power becomes greater than the power that can be absorbed by the braking resistor, an error message is generated and the power stage is disabled.

Parameter name HMI menu HMI name	Description	Unit Minimum value Factory setting Maximum value	Data type R/W Persistent Expert	Parameter address via fieldbus
<i>RESint_ext</i> <i>CONF → ACG -</i> <i>Eibr</i>	Selection of type of braking resistor. 0 / Internal Braking Resistor / INT : Internal braking resistor 1 / External Braking Resistor / EXT : External braking resistor 2 / Reserved / RSVd : Reserved Setting can only be modified if power stage is disabled. Modified settings become active the next time the power stage is enabled.	- 0 0 2	UINT16 R/W per. -	Modbus 1298
<i>REExt_P</i> <i>CONF → ACG -</i> <i>Pabr</i>	Nominal power of external braking resistor. The maximum value depends on the power stage. Setting can only be modified if power stage is disabled. Modified settings become active the next time the power stage is enabled.	W 1 10 -	UINT16 R/W per. -	Modbus 1316
<i>REExt_R</i> <i>CONF → ACG -</i> <i>rbr</i>	Resistance value of external braking resistor. The minimum value depends on the power stage. In increments of 0.01 Ω. Setting can only be modified if power stage is disabled. Modified settings become active the next time the power stage is enabled.	Ω - 100.00 327.67	UINT16 R/W per. -	Modbus 1318
<i>REExt_ton</i> <i>CONF → ACG -</i> <i>tbr</i>	Maximum permissible switch-on time of external braking resistor. Setting can only be modified if power stage is disabled. Modified settings become active the next time the power stage is enabled.	ms 1 1 30000	UINT16 R/W per. -	Modbus 1314

Autotuning

General

Autotuning moves the motor in order to tune the control loops. Incorrect parameters may cause unintended movements or the loss of monitoring functions.

⚠ WARNING

UNINTENDED MOVEMENT

- Only start the system if there are no persons or obstructions in the zone of operation.
- Verify that the values for the parameters *AT_dir* and *AT_dis_usr* (*AT_dis*) do not exceed the available movement range.
- Verify that the parameterized movement ranges are available, free and clear for the mechanical movement defined by your application logic.
- Include in your calculations when determining the available movement range the additional distance for the deceleration ramp in the case of an emergency stop.
- Verify that the parameter settings for a Quick Stop are correct.
- Verify correct operation of the limit switches.
- Verify that a functioning emergency stop push-button is within reach of all persons involved in all phases of machine operation and maintenance involving this equipment.

Failure to follow these instructions can result in death, serious injury, or equipment damage.

Autotuning determines the friction torque as a constantly acting load torque and considers it in the calculation of the moment of inertia of the entire system.

External factors such as a load at the motor are considered. Autotuning optimizes the settings of the control loop parameters, see *Controller Optimization with Step Response*, page 147.

Autotuning also supports vertical axes.

Methods

There are three ways of tuning the drive control loops:

- **Easy Tuning:** Automatic - autotuning without user intervention. For most applications, autotuning yields good, highly dynamic results.
- **Comfort Tuning:** Semi-automatic - autotuning with user intervention. Parameters for direction and parameters for damping can be set by the user.
- **Manual Tuning:** The user can set and tune the control loop parameters manually. Manual Tuning is available in the Expert Mode of the commissioning software.

Function

During autotuning, the motor is activated and small movements are made. Noise development and mechanical oscillations of the system are normal.

If you want to perform Easy Tuning, no additional parameters need to be adjusted. To perform Comfort Tuning, the parameters *AT_dir*, *AT_dis_usr* and *AT_mechanics* are available to be adjusted to meet the requirements of your application.

The parameter *AT_Start* is used to start Easy Tuning or Comfort Tuning.

- Start autotuning via the commissioning software.
It is also possible to start autotuning via the HMI.

HMI: $\alpha P \rightarrow t u n \rightarrow t u 5 t$

- Save the new settings to the nonvolatile memory via the commissioning software.

If you have started autotuning via the HMI, press the navigation button to save the new values to the nonvolatile memory.

The product features 2 control loop parameter sets that can be parameterized separately. The values for the control loop parameters determined during autotuning are stored in control loop parameter set 1.

If autotuning cancels with an error message, the default values are used. Change the mechanical position and restart autotuning. If you want to verify the plausibility of the calculated values, you can have them displayed; see Enhanced Settings for Autotuning, page 145.

Parameter name	Description	Unit	Data type	Parameter address via fieldbus
HMI menu		Minimum value	R/W	
HMI name		Factory setting	Persistent	
		Maximum value	Expert	
AT_dir $\alpha P \rightarrow t u n -$ $5 t , n$	Direction of movement for Autotuning. 1 / Positive Negative Home / P n h : Positive direction first, then negative direction with return to initial position 2 / Negative Positive Home / n P h : Negative direction first, then positive direction with return to initial position 3 / Positive Home / P - h : Positive direction only with return to initial position 4 / Positive / P - - : Positive direction only without return to initial position 5 / Negative Home / n - h : Negative direction only with return to initial position 6 / Negative / n - - : Negative direction only without return to initial position Modified settings become active the next time the motor moves.	- 1 1 6	UINT16 R/W - -	Modbus 12040
AT_dis_usr	Movement range for Autotuning. Movement range within which the control parameters are automatically optimized. The movement range is entered with reference to the actual position. In the case of "Movement in one direction only" (Parameter AT_dir), the specified range is used for each optimization step. The movement typically corresponds to 20 times the value, but it is not limited. The minimum value, the factory setting and the maximum value depend on the scaling factor. Modified settings become active the next time the motor moves. Available with firmware version $\geq V01.05$.	usr_p 1 32768 2147483647	INT32 R/W - -	Modbus 12068

Parameter name	Description	Unit	Data type	Parameter address via fieldbus
HMI menu		Minimum value	R/W	
HMI name		Factory setting	Persistent	
		Maximum value	Expert	
<i>AT_mechanical</i>	Type of coupling of the system. 1 / Direct Coupling: Direct coupling 2 / Belt Axis: Belt axis 3 / Spindle Axis: Spindle axis Modified settings become active the next time the motor moves.	- 1 2 3	UINT16 R/W - -	Modbus 12060
<i>AT_start</i>	Autotuning start. Value 0: Terminate Value 1: Activate EasyTuning Value 2: Activate ComfortTuning Modified settings become active immediately.	- 0 - 2	UINT16 R/W - -	Modbus 12034

Enhanced Settings for Autotuning

Description

The following parameters allow you to monitor and influence autotuning.

The parameters *AT_state* and *AT_progress* allow you to monitor the progress and status of autotuning.

Parameter name	Description	Unit	Data type	Parameter address via fieldbus
HMI menu		Minimum value	R/W	
HMI name		Factory setting	Persistent	
		Maximum value	Expert	
<i>_AT_state</i>	Autotuning status. Bit assignments: Bits 0 ... 10: Last processing step Bit 13: auto_tune_process Bit 14: auto_tune_end Bit 15: auto_tune_err	- - - -	UINT16 R/- - -	Modbus 12036
<i>_AT_progress</i>	Progress of Autotuning.	% 0 0 100	UINT16 R/- - -	Modbus 12054

If, in a test run, you want to determine the effects of harder or softer settings of the control loop parameters on your system, you can write the parameter *CTRL_GlobGain* to modify the settings determined during autotuning. The parameter *_AT_J* allows you to read the moment of inertia of the entire system calculated during autotuning.

Parameter name	Description	Unit	Data type	Parameter address via fieldbus
HMI menu		Minimum value	R/W	
HMI name		Factory setting	Persistent	
		Maximum value	Expert	
<i>CTRL_GlobGain</i> <i>o P → t u n -</i> <i>G R i n</i>	<p>Global gain factor (affects control loop parameter set 1).</p> <p>The global gain factor affects the following parameters of control loop parameter set 1:</p> <ul style="list-style-type: none"> - CTRL_KPn - CTRL_TNn - CTRL_KPp - CTRL_TAUref <p>The global gain factor is set to 100%</p> <ul style="list-style-type: none"> - if the control loop parameters are set to default - at the end of the Autotuning process - if control loop parameter set 2 is copied to set 1 via the parameter CTRL_ParSetCopy <p>In increments of 0.1 %.</p> <p>Modified settings become active immediately.</p>	%	UINT16	Modbus 4394
		5.0	R/W	
		100.0	per.	
		1000.0	-	
<i>_AT_M_friction</i>	<p>Friction torque of the system.</p> <p>Is determined during Autotuning.</p> <p>In increments of 0.01 A_{rms}.</p>	A_{rms}	UINT16	Modbus 12046
		-	R/-	
		-	-	
		-	-	
<i>_AT_M_load</i>	<p>Constant load torque.</p> <p>Is determined during Autotuning.</p> <p>In increments of 0.01 A_{rms}.</p>	A_{rms}	INT16	Modbus 12048
		-	R/-	
		-	-	
		-	-	
<i>_AT_J</i>	<p>Moment of inertia of the system.</p> <p>Is automatically calculated during Autotuning.</p> <p>In increments of 0.1 kg cm².</p>	kg cm ²	UINT16	Modbus 12056
		0.1	R/-	
		0.1	per.	
		6553.5	-	

The parameter *AT_wait* lets you set a waiting time between the individual autotuning steps. Setting a waiting time is only useful in the case of a low-rigidity coupling, in particular so if the next autotuning step (changing the hardness) is already performed while the system is still settling.

Parameter name	Description	Unit	Data type	Parameter address via fieldbus
HMI menu		Minimum value	R/W	
HMI name		Factory setting	Persistent	
		Maximum value	Expert	
<i>AT_wait</i>	<p>Waiting time between Autotuning steps.</p> <p>Modified settings become active the next time the motor moves.</p>	ms	UINT16	Modbus 12050
		300	R/W	
		500	-	
		10000	-	

Controller Optimization with Step Response

Controller Structure

Overview

The controller structure corresponds to the classical cascaded closed loop with current controller, velocity controller and position controller. In addition, the reference value of the velocity controller can be smoothed via a filter.

The controllers are tuned one after the other from the "inside" to the "outside" in the following sequence: current control, velocity control, position control.

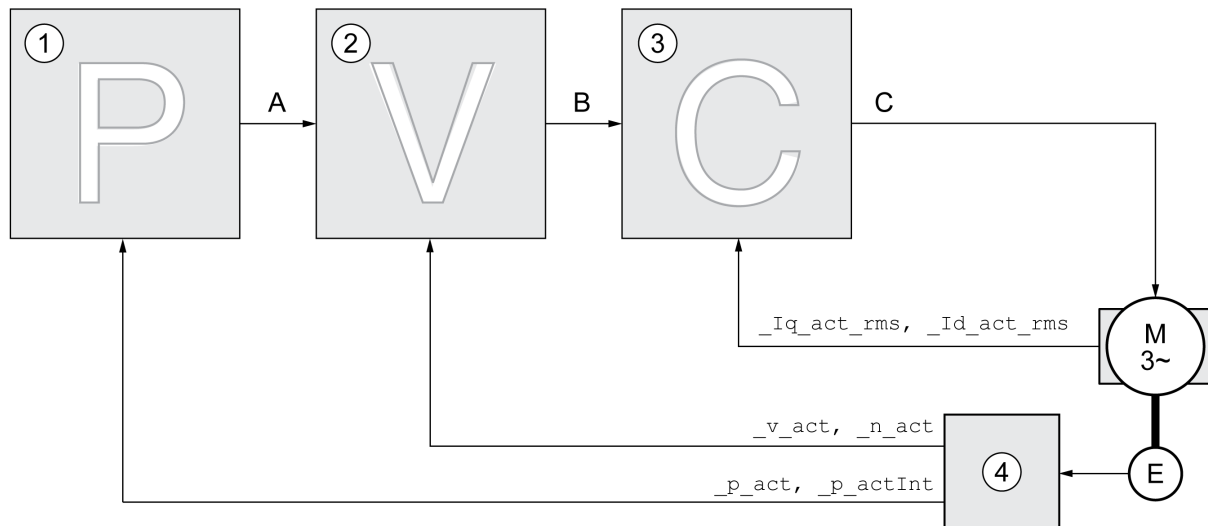

- 1 Position controller
- 2 Velocity controller
- 3 Current controller
- 4 Encoder evaluation

See section [Overview of the Controller Structure](#), page 188 for a detailed description of the controller structure.

Current Controller

The current controller determines the torque of the motor. The current controller is automatically optimally tuned with the stored motor data.

Velocity Controller

The velocity controller controls the motor velocity by varying the motor current depending on the load situation. The velocity controller has a decisive influence on the dynamic response of the drive. The dynamics of the velocity controller depend on:

- Moment of inertia of the drive and the controlled system
- Power of the motor
- Stiffness and elasticity of the elements in the flow of forces
- Backlash of the drive elements
- Friction

Position Controller

The position controller reduces the difference between the reference position and the actual position of the motor (position deviation) to a minimum. When the motor is at a standstill, the position deviation is close to zero in the case of a well-tuned position controller.

An optimized velocity control loop is a prerequisite for good amplification of the position controller.

Control Loop Parameters

This device allows you to use two control loop parameter sets. It is possible to switch from one set of control loop parameter sets to the other during operation. The active control loop parameter set is selected with the parameter *CTRL_SelParSet*.

The corresponding parameters are *CTRL1_xx* for the first control loop parameter set and *CTRL2_xx* for the second control loop parameter set. The following descriptions use the notation *CTRL1_xx* (*CTRL2_xx*) if there are no functional differences between the two control loop parameter sets.

Parameter name HMI menu HMI name	Description	Unit Minimum value Factory setting Maximum value	Data type R/W Persistent Expert	Parameter address via fieldbus
<i>CTRL_SelParSet</i>	Selection of control loop parameter set. Coding see parameter: <i>CTRL_PwrUpParSet</i> Modified settings become active immediately.	- 0 1 2	UINT16 R/W - -	Modbus 4402
<i>_CTRL_ActParSet</i>	Active control loop parameter set. Value 1: Control loop parameter set 1 is active Value 2: Control loop parameter set 2 is active A control loop parameter set is active after the time for the parameter switching (<i>CTRL_ParChgTime</i>) has elapsed.	- - - -	UINT16 R/- - -	Modbus 4398
<i>CTRL_ParChgTime</i>	Period of time for control loop parameter set switching. In the case of control loop parameter set switching, the values of the following parameters are changed linearly: - <i>CTRL_KPn</i> - <i>CTRL_TNn</i> - <i>CTRL_KPp</i> - <i>CTRL_TAUref</i> - <i>CTRL_TAUiref</i> - <i>CTRL_KFPp</i> Modified settings become active immediately.	ms 0 0 2000	UINT16 R/W per. -	Modbus 4392

Optimization

General

The drive optimization function matches the device to the application conditions. The following options are available:

- Selecting control loops. Upstream control loops are automatically deactivated.
- Defining reference value signals: signal type, amplitude, frequency and starting point
- Testing control performance with the signal generator.
- Recording the control performance on screen and evaluating it with the commissioning software.

Setting Reference Value Signals

Start controller optimization with the commissioning software.

Set the following values for the reference value signal:

- Signal type: Step "positive"
- Amplitude: 100 RPM
- Cycle duration: 100 ms
- Number of repetitions: 1
- Start the trace.

Only the signal types "Step" and "Square" allow you to determine the entire dynamic behavior of a control loop. The manual shows signal paths for the signal type "Step".

Entering Values for Optimization

The optimization steps described on the following pages require you to enter control loop parameters and test their effect by triggering a step function.

A step function is triggered as soon as you start a trace in the commissioning software.

Control Loop Parameters

This device allows you to use two control loop parameter sets. It is possible to switch from one set of control loop parameter sets to the other during operation. The active control loop parameter set is selected with the parameter *CTRL_SelParSet*.

The corresponding parameters are *CTRL1_xx* for the first control loop parameter set and *CTRL2_xx* for the second control loop parameter set. The following descriptions use the notation *CTRL1_xx* (*CTRL2_xx*) if there are no functional differences between the two control loop parameter sets.

For details see section [Switching Between Control Loop Parameter Sets](#), page 188.

Optimizing the Velocity Controller

General

Optimizing complex mechanical control systems require hands-on experience with controller tuning. This includes the ability to calculate control loop parameters and to apply identification procedures.

Less complex mechanical systems can often be optimized by means of experimental adjustment using the aperiodic limit method. The following parameters are used for this:

Parameter name HMI menu HMI name	Description	Unit Minimum value Factory setting Maximum value	Data type R/W Persistent Expert	Parameter address via fieldbus
<i>CTRL1_KPn</i> <i>CONF → drC - Pn1</i>	Velocity controller P gain. The default value is calculated on the basis of the motor parameters. In the case of switching between the two control loop parameter sets, the values are changed linearly over the time defined in the parameter CTRL_ParChgTime. In increments of 0.0001 A/RPM. Modified settings become active immediately.	A/RPM 0.0001 - 2.5400	UINT16 R/W per. -	Modbus 4610
<i>CTRL2_KPn</i> <i>CONF → drC - Pn2</i>	Velocity controller P gain. The default value is calculated on the basis of the motor parameters. In the case of switching between the two control loop parameter sets, the values are changed linearly over the time defined in the parameter CTRL_ParChgTime. In increments of 0.0001 A/RPM. Modified settings become active immediately.	A/RPM 0.0001 - 2.5400	UINT16 R/W per. -	Modbus 4866
<i>CTRL1_TNn</i> <i>CONF → drC - Tin1</i>	Velocity controller integral action time. The default value is calculated. In the case of switching between the two control loop parameter sets, the values are changed linearly over the time defined in the parameter CTRL_ParChgTime. In increments of 0.01 ms. Modified settings become active immediately.	ms 0.00 - 327.67	UINT16 R/W per. -	Modbus 4612
<i>CTRL2_TNn</i> <i>CONF → drC - Tin2</i>	Velocity controller integral action time. The default value is calculated. In the case of switching between the two control loop parameter sets, the values are changed linearly over the time defined in the parameter CTRL_ParChgTime. In increments of 0.01 ms. Modified settings become active immediately.	ms 0.00 - 327.67	UINT16 R/W per. -	Modbus 4868

Verify and optimize the calculated values in a second step, see [Verifying and Optimizing the P Gain](#), page 154.

Reference Value Filter of the Velocity Controller

The reference value filter of the velocity controller allows you to improve the transient response at optimized velocity control. The reference value filter must be deactivated for the first setup of the velocity controller.

Deactivate the reference value filter of the velocity controller. Set the parameter *CTRL1_TAUnref* (*CTRL2_TAUnref*) to the lower limit value "0".

Parameter name	Description	Unit	Data type	Parameter address via fieldbus
HMI menu		Minimum value	R/W	
HMI name		Factory setting	Persistent	
		Maximum value	Expert	
<i>CTRL1_TAUref</i> <i>CONF → dr C -</i> <i>TAU 1</i>	Filter time constant of the reference velocity value filter. In the case of switching between the two control loop parameter sets, the values are changed linearly over the time defined in the parameter CTRL_ParChgTime. In increments of 0.01 ms. Modified settings become active immediately.	ms 0.00 9.00 327.67	UINT16 R/W per. -	Modbus 4616
<i>CTRL2_TAUref</i> <i>CONF → dr C -</i> <i>TAU 2</i>	Filter time constant of the reference velocity value filter. In the case of switching between the two control loop parameter sets, the values are changed linearly over the time defined in the parameter CTRL_ParChgTime. In increments of 0.01 ms. Modified settings become active immediately.	ms 0.00 9.00 327.67	UINT16 R/W per. -	Modbus 4872

Determining the Type of Mechanical System

To assess and optimize the transient response behavior of your system, group its mechanical system into one of the following two categories.

- System with rigid mechanical system
- System with a less rigid mechanical system

Rigid and less rigid mechanical systems

Rigid mechanical system

low elasticity

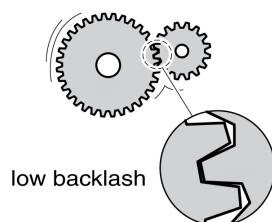
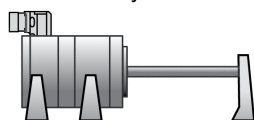

low backlash

e. g. Direct drive
Rigid coupling

Less rigid mechanical system

higher elasticity

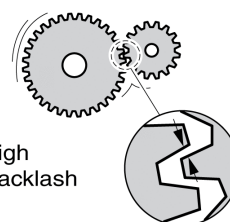

high backlash

e. g. Belt drive
Weak drive shaft
Elastic coupling

Determining Values for Rigid Mechanical Systems

In the case of a rigid mechanical system, adjusting the control performance on the basis of the table is possible if:

- the moment of inertia of the load and of the motor are known and
- the moment of inertia of the load and of the motor are constant

The P gain *CTRL_KPn* and the integral action time *CTRL_TNn* depend on:

- J_L : Moment of inertia of the load

- J_M : Moment of inertia of the motor
- Determine the values on the basis of the following table:

J_L	$J_L = J_M$		$J_L = 5 * J_M$		$J_L = 10 * J_M$	
	KPn	TNn	KPn	TNn	KPn	TNn
1 kgcm ²	0.0125	8	0.008	12	0.007	16
2 kgcm ²	0.0250	8	0.015	12	0.014	16
5 kgcm ²	0.0625	8	0.038	12	0.034	16
10 kgcm ²	0.125	8	0.075	12	0.069	16
20 kgcm ²	0.250	8	0.150	12	0.138	16

Determining Values for Less Rigid Mechanical Systems

For optimization purposes, determine the P gain of the velocity controller at which the controller adjusts velocity $_v_act$ as quickly as possible without overshooting.

Set the integral action time $CTRL1_TNn$ ($CTRL2_TNn$) to infinite (= 327.67 ms).

If a load torque acts on the motor when the motor is at a standstill, the integral action time must not exceed a value that causes unwanted changes of the motor position.

If the motor is subject to loads when it is at a standstill, setting the integral action time to "infinite" may cause position deviations (for example, in the case of vertical axes). Reduce the integral action time if the position deviation is unacceptable in your application. However, reducing the integral action time can adversely affect optimization results.

The step function moves the motor until the specified time has expired.

⚠ WARNING

UNINTENDED MOVEMENT

- Only start the system if there are no persons or obstructions in the zone of operation.
- Verify that the values for the velocity and the time do not exceed the available movement range.
- Verify that a functioning emergency stop push-button is within reach of all persons involved in the operation.

Failure to follow these instructions can result in death, serious injury, or equipment damage.

- Trigger a step function.
- After the first test, verify the maximum amplitude for the reference value for the current $_Iq_ref$.

Set the amplitude of the reference value just high enough so the reference value for the current $_Iq_ref$ remains below the maximum value $CTRL_I_max$. On the other hand, the value selected should not be too low, otherwise friction effects of the mechanical system will determine the performance of the control loop.

- Trigger another step function if you had to modify $_v_ref$ and verify the amplitude of $_Iq_ref$.
- Increase or decrease the P gain in small increments until $_v_act$ is obtained as fast as possible. The following diagram shows the required transient response on the left. Overshooting - as shown on the right - is reduced by reducing $CTRL1_KPn$ ($CTRL2_KPn$).

Differences between $_v_ref$ and $_v_act$ result from setting $CTRL1_TNn$ ($CTRL2_TNn$) to "Infinite".

Determining "TNn" for the aperiodic limit

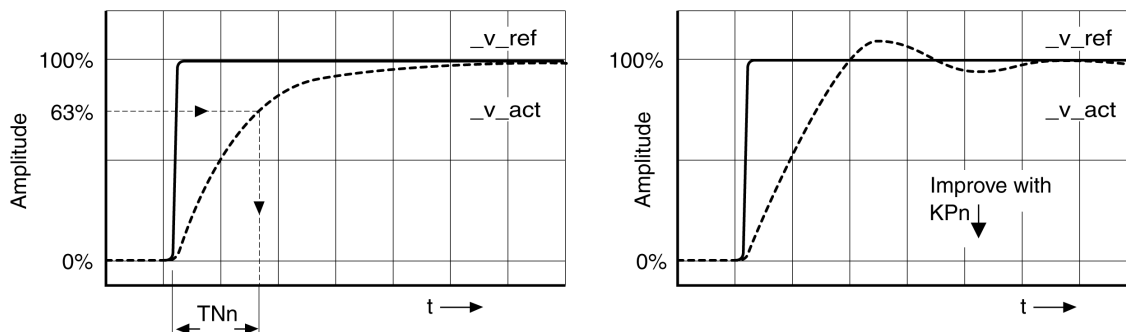

In the case of drive systems in which oscillations occur before the aperiodic limit is reached, the P gain "KPn" must be reduced until oscillations can no longer be detected. This occurs frequently in the case of linear axes with a toothed belt drive.

Graphic Determination of the 63% Value

Graphically determine the point at which the actual velocity *v_act* reaches 63% of the final value. The integral action time *CTRL1_TNn* (*CTRL2_TNn*) then results as a value on the time axis. The commissioning software supports you with the evaluation:

Parameter name HMI menu HMI name	Description	Unit Minimum value Factory setting Maximum value	Data type R/W Persistent Expert	Parameter address via fieldbus
<i>CTRL1_TNn</i> CONF → dr C - E i n 1	Velocity controller integral action time. The default value is calculated. In the case of switching between the two control loop parameter sets, the values are changed linearly over the time defined in the parameter CTRL_ParChgTime. In increments of 0.01 ms. Modified settings become active immediately.	ms 0.00 - 327.67	UINT16 R/W per. -	Modbus 4612
<i>CTRL2_TNn</i> CONF → dr C - E i n 2	Velocity controller integral action time. The default value is calculated. In the case of switching between the two control loop parameter sets, the values are changed linearly over the time defined in the parameter CTRL_ParChgTime. In increments of 0.01 ms. Modified settings become active immediately.	ms 0.00 - 327.67	UINT16 R/W per. -	Modbus 4868

Verifying and Optimizing the P Gain

General

Step responses with good control performance

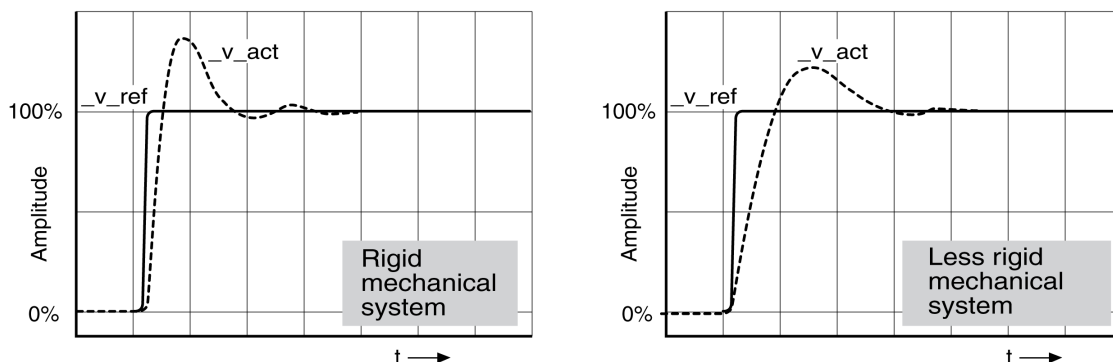

The controller is properly set when the step response is approximately identical to the signal shown. Good control performance is characterized by

- Fast transient response
- Overshooting with 20%, up to a maximum of 40%.

If the control performance does not correspond to the curve shown, change $CTRL_KPn$ in increments of about 10% and then trigger another step function:

- If the control is too slow: Use a higher $CTRL1_KPn$ ($CTRL2_KPn$) value.
- If the control tends to oscillate: Use a lower $CTRL1_KPn$ ($CTRL2_KPn$) value.

Oscillation ringing is characterized by continuous acceleration and deceleration of the motor.

Optimizing insufficient velocity controller settings

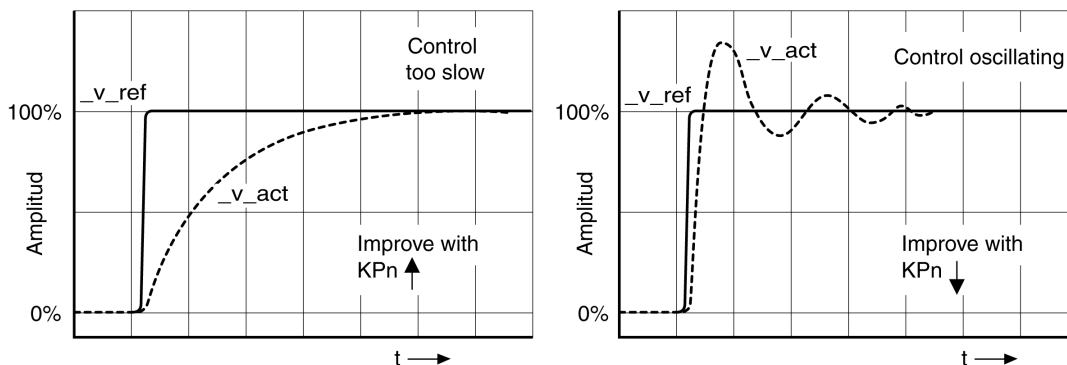

Optimizing the Position Controller

General

An optimized velocity controller is a prerequisite for optimization of the position controller.

When tuning the position controller, you must optimize the P gain $CTRL1_KPp$ ($CTRL2_KPp$):

- $CTRL1_KPp$ ($CTRL2_KPp$) too high: Overshooting, instability
- $CTRL1_KPp$ ($CTRL2_KPp$) too low: High position deviation

Parameter name HMI menu HMI name	Description	Unit Minimum value Factory setting Maximum value	Data type R/W Persistent Expert	Parameter address via fieldbus
<i>CTRL1_KPp</i> <i>ConF → drC -</i> <i>PP1</i>	Position controller P gain. The default value is calculated. In the case of switching between the two control loop parameter sets, the values are changed linearly over the time defined in the parameter CTRL_ParChgTime. In increments of 0.1 1/s. Modified settings become active immediately.	1/s 2.0 - 900.0	UINT16 R/W per. -	Modbus 4614
<i>CTRL2_KPp</i> <i>ConF → drC -</i> <i>PP2</i>	Position controller P gain. The default value is calculated. In the case of switching between the two control loop parameter sets, the values are changed linearly over the time defined in the parameter CTRL_ParChgTime. In increments of 0.1 1/s. Modified settings become active immediately.	1/s 2.0 - 900.0	UINT16 R/W per. -	Modbus 4870

The step function moves the motor until the specified time has expired.

⚠ WARNING

UNINTENDED MOVEMENT

- Only start the system if there are no persons or obstructions in the zone of operation.
- Verify that the values for the velocity and the time do not exceed the available movement range.
- Verify that a functioning emergency stop push-button is within reach of all persons involved in the operation.

Failure to follow these instructions can result in death, serious injury, or equipment damage.

Setting the Reference Value Signal

- Select Position Controller as the reference value in the commissioning software.
- Set the reference value signal:
- Signal type: "Step"
- Set the amplitude to approximately 1/10 motor revolution.

The amplitude is entered in user-defined units. With the default scaling, the resolution is 16384 user-defined units per motor revolution.

Selecting the Trace Signals

- Select the values in the box General Trace Parameters:
- Reference position of position controller *_p_refusr* (*_p_ref*)
- Actual position of position controller *_p_actusr* (*_p_act*)
- Actual velocity *_v_act*
- Reference value current *_lq_ref*

Optimizing the Position Controller Value

- Trigger a step function with the default controller values.
- After the first test, verify the values achieved for *_v_act* and *_lq_ref* for current control and velocity control. The values must not reach the current and velocity limitation range.

Step responses of a position controller with good control performance

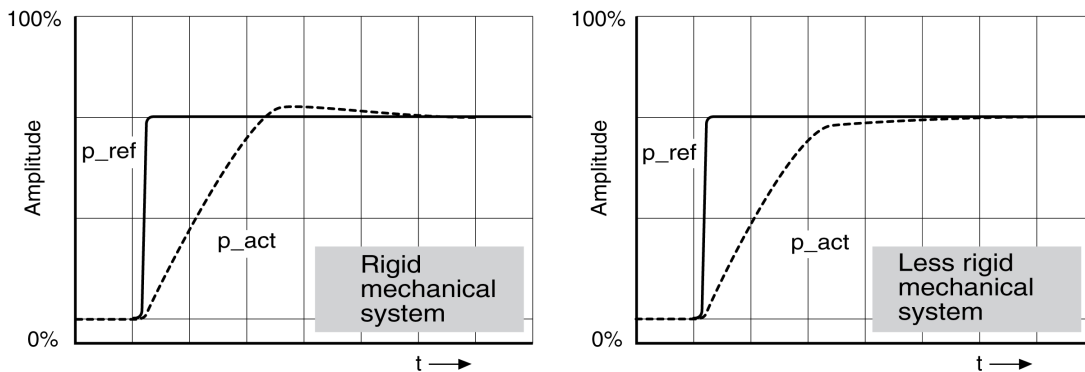

The p gain setting *CTRL1_KPp* (*CTRL2_KPp*) is optimal if the reference value is reached rapidly and with little or no overshooting.

If the control performance does not correspond to the curve shown, change the P gain *CTRL1_KPp* (*CTRL2_KPp*) in increments of approximately 10% and trigger another step function.

- If the control tends to oscillate: Use a lower KPp value.
- If the actual value is too slow reaching the reference value: Use a higher KPp value.

Optimizing inadequate position controller settings

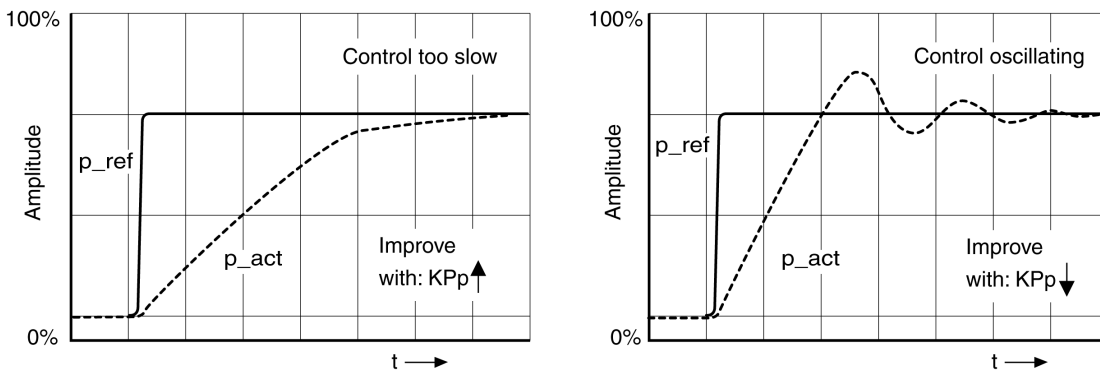

Parameter Management

Memory Card

Description

The drives features a card holder for a memory card. The parameters stored on the memory card can be transferred to other drives. If a drive is replaced, a new drive of the same type can be operated with identical parameters.

The contents of the memory card is compared to the parameters stored in the drive when the drive is powered on.

When the parameters are written to the nonvolatile memory, they are also saved to the memory card.

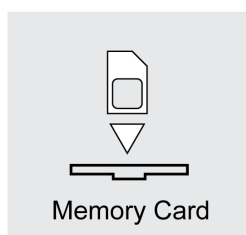

Note the following:

- Use only genuine accessory memory cards.
- Do not touch the gold contacts.
- The insert/remove cycles of the memory card are limited.
- The memory card can remain in the drive.
- The memory card can only be removed from the drive by pulling (not by pushing).

NOTICE

ELECTROSTATIC DISCHARGE OR INTERMITTENT CONTACT AND LOSS OF DATA

Do not touch the contacts of the memory card.

Failure to follow these instructions can result in equipment damage.

Inserting a Memory Card

- 24 Vdc control supply has been powered off.
- Insert the memory card into the drive with the gold contacts face down; the slanted corner must be face to the mounting plate.
- Power on the 24 Vdc control supply.
- Observe the 7-segment display during the initialization of the drive.

[R r d] is Displayed for a Short Period of Time

The drive has detected a memory card. User intervention is not required.

The parameter values stored in the drive and the contents of the memory card are identical. The data on the memory card originates from the drive into which the memory card is inserted.

***CARD* is Displayed Permanently**

The drive has detected a memory card. User intervention is required.

Cause	Options
The memory card is new.	The drive data can be transferred to the memory card.
The data on the memory card does not match the drive (different drive type, different motor type, different firmware version).	The drive data can be transferred to the memory card.
The data on the memory card matches the drive, but the parameter values are different.	<p>The drive data can be transferred to the memory card.</p> <p>The data on the memory card can be transferred to the drive. If the memory card is to remain in the drive, the drive data must be transferred to the memory card.</p>

***CARD* is Not Displayed**

The drive has not detected a memory card. Power off the 24 Vdc control supply. Verify that the memory card has been properly inserted (contacts, slanted corner).

Data Exchange with the Memory Card

If there are differences between the parameters on the memory card and the parameters stored in the drive, the drive stops after initialization and displays *CARD*.

Copying Data or Ignoring the Memory Card (*CARD*, *IGNR*, *CTOD*, *DTOC*)

If the 7-segment display shows *CARD*:

- Press the navigation button.
The 7-segment display shows the last setting, for example *IGNR*.
- Briefly press the navigation button to activate the Edit mode.
The 7-segment display continues to display the last setting, the LED Edit illuminates.
- Select with the navigation button:
 - IGNR* ignores the memory card.
 - CTOD* transfers the data from the memory card to the drive.
 - DTOC* transfers the data from the drive to the memory card.
 The drive switches to operating state **4** Ready To Switch On.

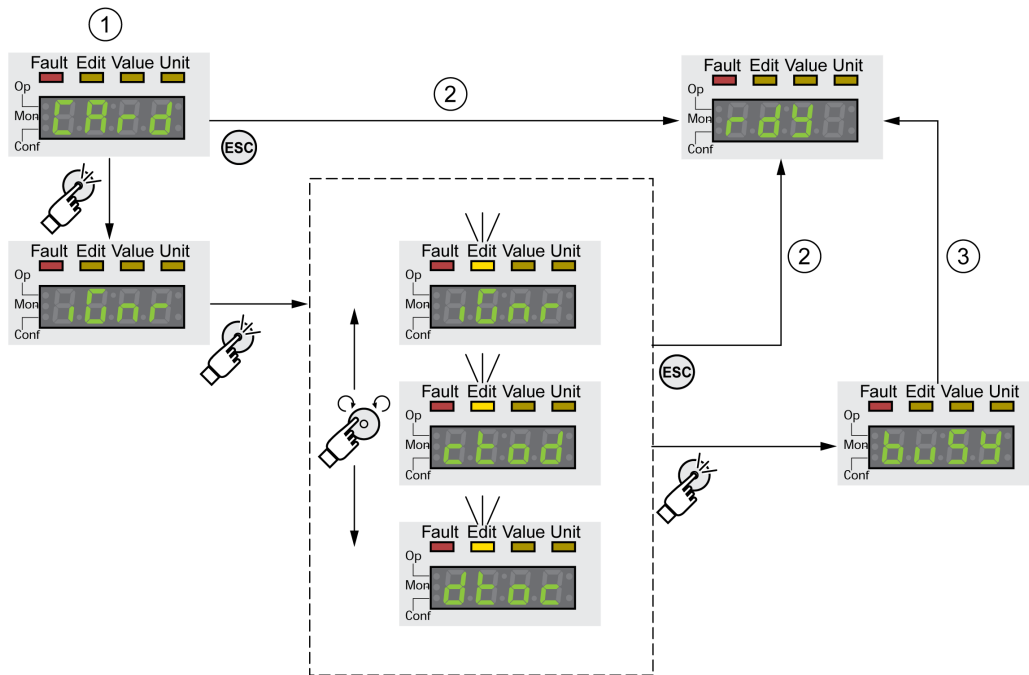

1 Data on the memory card and in the drive are different: The drive displays *c R r d* and waits for user intervention.

2 Transition to operating state 4 Ready To Switch On (memory card is ignored).

3 Transfer of data (*c t o d* = card to drive, *d t o c* = drive to card) and transition to operating state 4 Ready To Switch On.

Memory Card has Been Removed (*c R r d*, *n i s s*)

If you removed the memory card, the drive displays *c R r d* after initialization. If you confirm this, the display shows *n i s s*. If you confirm again, the product transitions to the operating state .4 Ready To Switch On.

Write Protection for Memory Card (*c R r d*, *E n P r*, *d i P r*, *P r o t*)

It is possible to write-protect the memory card (*P r o t*). For example, you may want to write-protect memory cards used for regular duplication of drive data.

To write-protect the memory card, select *C o n F - R C G - c R r d* on the HMI.

Selection	Meaning
<i>E n P r</i>	Write protection on (<i>P r o t</i>)
<i>d i P r</i>	Write protection off

Memory cards can also be write-protected via the commissioning software.

Duplicating Existing Parameter Values

Application

Multiple devices are to have the same settings, for example, when devices are replaced.

Prerequisites

- Device type, motor type and firmware version must be identical.

- Tools for duplication:
 - Memory card
 - Commissioning software
- The 24 Vdc control supply must be powered on.

Duplication Using a Memory Card

Device settings can be stored on a memory card (accessories).

The stored device settings can be copied to a device of the same type. Note that the fieldbus address and the settings for the monitoring functions are copied along with this information.

Duplication Using the Commissioning Software

The commissioning software can save the settings of a device in the form of a configuration file. The stored device settings can be copied to a device of the same type. Note that the fieldbus address and the settings for the monitoring functions are copied along with this information.

See the manual for the commissioning software for additional information.

Resetting the User Parameters

Description

The user parameters are reset by means of the parameter *PARuserReset*.

Disconnect the drive from the fieldbus.

Parameter name	Description	Unit	Data type	Parameter address via fieldbus
HMI menu		Minimum value	R/W	
HMI name		Factory setting	Persistent	
		Maximum value	Expert	
<i>PARuserReset</i>	Reset user parameters.	-	UINT16	Modbus 1040
<i>CONF → FCS - RESU</i>	<p>0 / No / n o: No</p> <p>65535 / Yes / Y E S: Yes</p> <p>Bit 0: Reset persistent user parameters and control loop parameters to default values</p> <p>Bits 1 ... 15: Reserved</p> <p>The parameters are reset with the exception of:</p> <ul style="list-style-type: none"> - Communication parameters - Inversion of direction of movement - Type of reference value signal for PTI interface - Operating mode - Settings of encoder simulation - Functions of digital inputs and outputs <p>The new settings are not saved to the EEPROM.</p> <p>Setting can only be modified if power stage is disabled.</p> <p>Modified settings become active the next time the power stage is enabled.</p>	<p>0</p> <p>-</p> <p>65535</p>	<p>R/W</p> <p>-</p> <p>-</p>	

Resetting via the HMI

Use the menu items `CONF -> FCS -> RESU` of the HMI to reset the user parameters. Confirm the selection with `YES`.

The new settings are not saved to the nonvolatile memory.

If the drive transitions to the operating state "2 Not Ready To Switch On" after the user parameters are reset, the new settings only become active after the 24 Vdc control supply of the drive is power cycled.

Resetting via the Commissioning Software

Use the menu items "Device -> User Functions -> Reset User Parameters" in the commissioning software to reset the user parameters.

If the drive transitions to the operating state "2 Not Ready To Switch On" after the user parameters are reset, the new settings only become active after the 24 Vdc control supply of the drive is power cycled.

Restoring Factory Settings

Description

The parameter values, both active and those saved in nonvolatile memory, are lost in this process.

NOTICE

LOSS OF DATA

Perform a backup of the drive parameters prior to restoring factory settings (factory established parameter values).

Failure to follow these instructions can result in equipment damage.

The commissioning software allows you to save the parameter values set for a drive as a configuration file. For information on saving the existing parameters in the drive, see [Parameter Management](#), page 157.

The factory settings can be restored via the HMI or the commissioning software.

Factory Settings via HMI

Use the menu items `CONF > FCS- > rStF` of the HMI to restore the factory settings. Confirm the selection with `YES`.

The new settings only become active until after the 24 Vdc control supply of the drive is power cycled.

Factory Settings via Commissioning Software

Use the menu items `Device > User Functions > Restore Factory Settings` in the commissioning software to restore the factory settings.

The new settings only become active until after the 24 Vdc control supply of the drive is power cycled.

Operation

Access Channels

Description

The product can be accessed via different types of access channels. Simultaneous access via multiple access channels or the use of exclusive access may cause unintended equipment operation.

⚠ WARNING

UNINTENDED EQUIPMENT OPERATION

- Verify that simultaneous access via multiple access channels cannot cause unintended triggering or blocking of commands.
- Verify that the use of exclusive access cannot cause unintended triggering or blocking of commands.
- Verify that the required access channels are available.

Failure to follow these instructions can result in death, serious injury, or equipment damage.

The product can be addressed via different access channels. Access channels are:

- Integrated HMI
- External graphic display terminal
- Commissioning software
- Analog signal inputs
- Digital signal inputs

Only one access channel can have exclusive access to the product. An exclusive access can be provided via different access channels:

- Via the integrated HMI:
The operating mode Jog or Autotuning can be started via the HMI.
- Via the commissioning software:
The commissioning software receives exclusive access via the switch "Exclusive access" in position "On".

When the drive is powered on, there is no exclusive access via an access channel.

The reference values are effective at the analog inputs and at the PTI interface when the drive is powered on. If exclusive access has been assigned to an access channel, signals at the analog inputs and the PTI interface are ignored.

The signal input functions "Halt", "Fault Reset", "Enable", "Positive Limit Switch (LIMP)", "Negative Limit Switch (LIMN)" and "Reference Switch (REF)" as well as the signals of the safety function STO (*STO_A* and *STO_B*) are available during exclusive access.

Parameter name HMI menu HMI name	Description	Unit Minimum value Factory setting Maximum value	Data type R/W Persistent Expert	Parameter address via fieldbus
<i>_AccessInfo</i>	<p>Access channel information.</p> <p>Low byte: Exclusive access</p> <p>Value 0: No</p> <p>Value 1: Yes</p> <p>High byte: Access channel</p> <p>Value 0: Reserved</p> <p>Value 1: I/O</p> <p>Value 2: HMI</p> <p>Value 3: Modbus RS485</p>	- - - -	UINT16 R/- - -	Modbus 280
<i>AccessLock</i>	<p>Locking other access channels.</p> <p>Value 0: Allow control via other access channels</p> <p>Value 1: Lock control via other access channels</p> <p>Example:</p> <p>The access channel is used by the fieldbus.</p> <p>In this case, control via the commissioning software, for example, is not possible.</p> <p>The access channel can only be locked after the currently active operating mode has terminated.</p> <p>Modified settings become active immediately.</p>	- 0 0 1	UINT16 R/W - -	Modbus 284
<i>HMIlocked</i>	<p>Lock HMI.</p> <p>0 / Not Locked / n L o c k : HMI not locked</p> <p>1 / Locked / L o c k : HMI locked</p> <p>The following functions can no longer be started when the HMI is locked:</p> <ul style="list-style-type: none"> - Parameter change - Jog - Autotuning - Fault Reset <p>Modified settings become active immediately.</p>	- 0 0 1	UINT16 R/W per. -	Modbus 14850

Movement Range

Size of the Movement Range

Description

The movement range is the maximum possible range within which a movement can be made to any position.

The actual position of the motor is the position in the movement range.

The figure below shows the movement range in user-defined units with the factory scaling.



A -268435456 user-defined units (usr_p)

B 268435455 user-defined units (usr_p)

Availability

The movement range is only relevant in the operating mode Jog.

Scaling

General

Overview

Scaling converts user-defined units into internal units of the device, and vice versa.

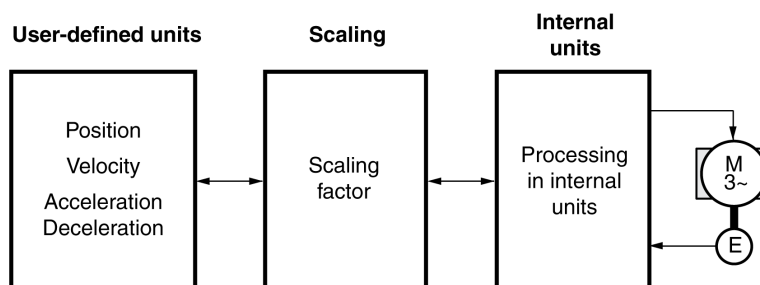

User-Defined Units

Values for positions, velocities, acceleration and deceleration are specified in the following user-defined unit:

- usr_p for positions
- usr_v for velocities
- usr_a for acceleration and deceleration

Modifying the scaling modifies the ratio between user-defined units and internal units. After a modification to the scaling, the same value of a parameter specified in a user-defined unit causes a different movement than before the modification. A modification of the scaling affects all parameters whose values are specified in user-defined units.

⚠ WARNING

UNINTENDED MOVEMENT

- Verify all parameters with user-defined units before modifying the scaling factor.
- Verify that a modification of the scaling factor cannot cause unintended movements.

Failure to follow these instructions can result in death, serious injury, or equipment damage.

Scaling Factor

The scaling factor is the relationship between the motor movement and the required user-defined units.

Commissioning Software

As of firmware version $\geq V01.06$, you can adjust the scaling via the commissioning software. The parameters with user-defined units are automatically adjusted.

Configuration of Position Scaling

Description

Position scaling is the relationship between the number of motor revolutions and the required user-defined units (usr_p).

Scaling Factor

Position scaling is specified by means of scaling factor:

In the case of a rotary motor, the scaling factor is calculated as shown below:

$$\frac{\text{Number of revolutions of the motor}}{\text{Number of user-defined units [usr_p]}}$$

A new scaling factor is activated when you specify the numerator value.

With a scaling factor of < 1 / 131072, it is not possible to perform a movement outside of the movement range.

Factory Setting

The following factory settings are used:

1 motor revolution corresponds to 16384 user-defined units

Parameter name HMI menu HMI name	Description	Unit Minimum value Factory setting Maximum value	Data type R/W Persistent Expert	Parameter address via fieldbus
ScalePOSnum	Position scaling: Numerator. Specification of the scaling factor: Motor revolutions ----- User-defined units [usr_p] A new scaling is activated when the numerator value is supplied. Setting can only be modified if power stage is disabled. Modified settings become active immediately.	revolution 1 1 2147483647	INT32 R/W per. -	Modbus 1552
ScalePOSdenom	Position scaling: Denominator. Refer to numerator (ScalePOSnum) for a description. A new scaling is activated when the numerator value is supplied. Setting can only be modified if power stage is disabled.	usr_p 1 16384 2147483647	INT32 R/W per. -	Modbus 1550

Configuration of Velocity Scaling

Description

Velocity scaling is the relationship between the number of motor revolutions per minute and the required user-defined units (usr_v).

Scaling Factor

Velocity scaling is specified by means of scaling factor:

In the case of a rotary motor, the scaling factor is calculated as shown below:

$$\frac{\text{Number of revolutions of the motor per minute}}{\text{Number of user-defined units [usr_v]}}$$

Factory Setting

The following factory settings are used:

1 motor revolution per minute corresponds to 1 user-defined unit

Parameter name HMI menu HMI name	Description	Unit Minimum value Factory setting Maximum value	Data type R/W Persistent Expert	Parameter address via fieldbus
<i>ScaleVELnum</i>	Velocity scaling: Numerator. Specification of the scaling factor: Speed of rotation of motor [RPM] ----- User-defined units [usr_v] A new scaling is activated when the numerator value is supplied. Setting can only be modified if power stage is disabled. Modified settings become active immediately.	RPM 1 1 2147483647	INT32 R/W per. -	Modbus 1604
<i>ScaleVELdenom</i>	Velocity scaling: Denominator. See numerator (ScaleVELnum) for a description. A new scaling is activated when the numerator value is supplied. Setting can only be modified if power stage is disabled.	usr_v 1 1 2147483647	INT32 R/W per. -	Modbus 1602

Configuration of Ramp Scaling

Description

Ramp scaling is the relationship between the change in velocity and the required user-defined units (usr_a).

Scaling Factor

Ramp scaling is specified by means of scaling factor:

$$\frac{\text{Velocity change per second}}{\text{Number of user-defined units [usr_a]}}$$

Factory Setting

The following factory settings are used:

A change of 1 motor revolution per minute per second corresponds to 1 user-defined unit.

Parameter name HMI menu HMI name	Description	Unit Minimum value Factory setting Maximum value	Data type R/W Persistent Expert	Parameter address via fieldbus
<i>ScaleRAMPnum</i>	Ramp scaling: Numerator. Setting can only be modified if power stage is disabled. Modified settings become active immediately.	RPM/s 1 1 2147483647	INT32 R/W per. -	Modbus 1634
<i>ScaleRAMPdenom</i>	Ramp scaling: Denominator. See numerator (ScaleRAMPnum) for a description. A new scaling is activated when the numerator value is supplied. Setting can only be modified if power stage is disabled.	usr_a 1 1 2147483647	INT32 R/W per. -	Modbus 1632

Digital Signal Inputs and Digital Signal Outputs

Parameterization of the Signal Input Functions

Signal Input Function

Various signal input functions can be assigned to the digital signal inputs.

The functions of the inputs and outputs depend on the selected operating mode and the settings of the corresponding parameters.

⚠ WARNING
<p>UNINTENDED EQUIPMENT OPERATION</p> <ul style="list-style-type: none"> • Verify that the wiring is appropriate for the factory settings and any subsequent parameterizations. • Only start the system if there are no persons or obstructions in the zone of operation. • Carefully run tests for all operating states and potential error situations when commissioning, upgrading or otherwise modifying the operation of the drive. <p>Failure to follow these instructions can result in death, serious injury, or equipment damage.</p>

Factory Settings

The table below shows the factory settings of the digital signal inputs depending on the selected operating mode:

Signal	Jog	Electronic Gear	Profile Torque	Profile Velocity
DI0	Enable	Enable	Enable	Enable
DI1	Fault Reset	Fault Reset	Fault Reset	Fault Reset
DI2	Positive Limit Switch (LIMP)	Positive Limit Switch (LIMP)	Operating Mode Switch	Operating Mode Switch
DI3	Negative Limit Switch (LIMN)	Negative Limit Switch (LIMN)	Velocity Limitation	Velocity Limitation
DI4	Jog negative	Gear Ratio Switch	Current Limitation	Zero Clamp
DI5	Jog positive	Halt	Halt	Halt

When the operating mode is changed and after the product is powered off and on, the factory settings are assigned to the digital signal inputs and digital signal outputs.

Parameterization

The table below provides an overview of the possible signal input functions depending on the selected operating mode:

Signal input function	Jog	Electronic Gear	Profile Torque	Profile Velocity	Description in section
Freely Available	•	•	•	•	-
Fault Reset	•	•	•	•	Changing the Operating State via Signal Inputs, page 206
Enable	•	•	•	•	Changing the Operating State via Signal Inputs, page 206
Halt	•	•	•	•	Stopping Movement with Halt, page 237
Current Limitation	•	•	•	•	Limitation of the Current via Signal Inputs, page 243
Zero Clamp		•		•	Zero Clamp, page 246
Velocity Limitation	•	•	•	•	Limitation of the Velocity via Signal Inputs, page 240
Jog Positive	•				Operating Mode Jog, page 210
Jog Negative	•				Operating Mode Jog, page 210
Jog Fast/Slow	•				Operating Mode Jog, page 210
Gear Ratio Switch		•			Operating Mode Electronic Gear, page 216
Gear Offset 1		•			Operating Mode Electronic Gear, page 216
Gear Offset 2		•			Operating Mode Electronic Gear, page 216
Positive Limit Switch (LIMP)	•	•	•	•	Limit Switches, page 252
Negative Limit Switch (LIMN)	•	•	•	•	Limit Switches, page 252
Switch Controller Parameter Set	•	•	•	•	Switching Between Control Loop Parameter Sets, page 188
Inversion AI1			•	•	Inverting the Analog Signal Inputs, page 240
Inversion AI2			•	•	Inverting the Analog Signal Inputs, page 240
Operating Mode Switch	•	•	•	•	Starting and Changing an Operating Mode, page 208
Velocity Controller Integral Off	•	•	•	•	Switching Between Control Loop Parameter Sets, page 188
Start Signal Of RMAC	•	•	•	•	Relative Movement After Capture (RMAC), page 246
Activate RMAC	•	•	•	•	Relative Movement After Capture (RMAC), page 246
Activate Operating Mode	•	•	•	•	Relative Movement After Capture (RMAC), page 246
Release Holding Brake	•	•	•	•	Releasing the Holding Brake Manually, page 135

The following parameters can be used to parameterize the digital signal inputs:

Parameter name HMI menu HMI name	Description	Unit Minimum value Factory setting Maximum value	Data type R/W Persistent Expert	Parameter address via fieldbus
<p><i>IOfunct_DI0</i></p> <p><i>CONF → , - - d , 0</i></p>	<p>Function Input DI0.</p> <p>1 / Freely Available / n o n E: Available as required</p> <p>2 / Fault Reset / F r E S: Fault reset after error</p> <p>3 / Enable / E n A B: Enables the power stage</p> <p>4 / Halt / h A L T: Halt</p> <p>6 / Current Limitation / , L , Π: Limits the current to parameter value</p> <p>7 / Zero Clamp / C L Π P: Zero clamping</p> <p>8 / Velocity Limitation / V L , Π: Limits the velocity to parameter value</p> <p>9 / Jog Positive / J o G P: Jog: Moves in positive direction</p> <p>10 / Jog Negative / J o G n: Jog: Moves in negative direction</p> <p>11 / Jog Fast/Slow / J o G F: Jog: Switches between slow and fast movement</p> <p>12 / Gear Ratio Switch / G r A T: Electronic Gear: Switches between two gear ratios</p> <p>19 / Gear Offset 1 / G o F 1: Electronic Gear: Adds first gear offset</p> <p>20 / Gear Offset 2 / G o F 2: Electronic Gear: Adds second gear offset</p> <p>21 / Reference Switch (REF) / r E F: Reference switch</p> <p>22 / Positive Limit Switch (LIMP) / L , Π P: Positive limit switch</p> <p>23 / Negative Limit Switch (LIMN) / L , Π n: Negative limit switch</p> <p>24 / Switch Controller Parameter Set / C P A r: Switches control loop parameter set</p> <p>25 / Inversion AI1 / A I , V: Inverts analog input AI1</p> <p>26 / Inversion AI2 / A 2 , V: Inverts analog input AI2</p> <p>27 / Operating Mode Switch / Π S W T: Switches operating mode</p> <p>28 / Velocity Controller Integral Off / E n o F: Switches off velocity controller integral term</p> <p>30 / Start Signal Of RMAC / S r Π c: Start signal of relative movement after capture (RMAC)</p> <p>31 / Activate RMAC / A r Π c: Activates the relative movement after capture (RMAC)</p> <p>32 / Activate Operating Mode / A c o P: Activates operating mode</p> <p>40 / Release Holding Brake / r E h B: Releases the holding brake</p> <p>Setting can only be modified if power stage is disabled.</p> <p>Modified settings become active the next time the product is powered on.</p>	<p>-</p> <p>-</p> <p>-</p> <p>-</p>	<p>UINT16</p> <p>R/W</p> <p>per.</p> <p>-</p>	<p>Modbus 1794</p>
<p><i>IOfunct_DI1</i></p> <p><i>CONF → , - - d , 1</i></p>	<p>Function Input DI1.</p> <p>1 / Freely Available / n o n E: Available as required</p> <p>2 / Fault Reset / F r E S: Fault reset after error</p>	<p>-</p> <p>-</p> <p>-</p>	<p>UINT16</p> <p>R/W</p> <p>per.</p>	<p>Modbus 1796</p>

Parameter name HMI menu HMI name	Description	Unit Minimum value Factory setting Maximum value	Data type R/W Persistent Expert	Parameter address via fieldbus
	<p>3 / Enable / E n A b: Enables the power stage</p> <p>4 / Halt / h A L t: Halt</p> <p>6 / Current Limitation / , L , n: Limits the current to parameter value</p> <p>7 / Zero Clamp / C L n P: Zero clamping</p> <p>8 / Velocity Limitation / V L , n: Limits the velocity to parameter value</p> <p>9 / Jog Positive / J o G P: Jog: Moves in positive direction</p> <p>10 / Jog Negative / J o G n: Jog: Moves in negative direction</p> <p>11 / Jog Fast/Slow / J o G F: Jog: Switches between slow and fast movement</p> <p>12 / Gear Ratio Switch / G r A t: Electronic Gear: Switches between two gear ratios</p> <p>19 / Gear Offset 1 / G o F 1: Electronic Gear: Adds first gear offset</p> <p>20 / Gear Offset 2 / G o F 2: Electronic Gear: Adds second gear offset</p> <p>21 / Reference Switch (REF) / r E F: Reference switch</p> <p>22 / Positive Limit Switch (LIMP) / L , n P: Positive limit switch</p> <p>23 / Negative Limit Switch (LIMN) / L , n n: Negative limit switch</p> <p>24 / Switch Controller Parameter Set / C P A r: Switches control loop parameter set</p> <p>25 / Inversion AI1 / A I 1 , V: Inverts analog input AI1</p> <p>26 / Inversion AI2 / A I 2 , V: Inverts analog input AI2</p> <p>27 / Operating Mode Switch / n S w t: Switches operating mode</p> <p>28 / Velocity Controller Integral Off / E n o F: Switches off velocity controller integral term</p> <p>30 / Start Signal Of RMAC / S r n c: Start signal of relative movement after capture (RMAC)</p> <p>31 / Activate RMAC / A r n c: Activates the relative movement after capture (RMAC)</p> <p>32 / Activate Operating Mode / A c o P: Activates operating mode</p> <p>40 / Release Holding Brake / r E h b: Releases the holding brake</p> <p>Setting can only be modified if power stage is disabled.</p> <p>Modified settings become active the next time the product is powered on.</p>	-	-	
IOfunc_DI2 CONF → , - a - d , 2	<p>Function Input DI2.</p> <p>1 / Freely Available / n o n E: Available as required</p> <p>2 / Fault Reset / F r E S: Fault reset after error</p> <p>3 / Enable / E n A b: Enables the power stage</p> <p>4 / Halt / h A L t: Halt</p> <p>6 / Current Limitation / , L , n: Limits the current to parameter value</p>	- - - -	UINT16 R/W per. -	Modbus 1798

Parameter name HMI menu HMI name	Description	Unit Minimum value Factory setting Maximum value	Data type R/W Persistent Expert	Parameter address via fieldbus
	<p>7 / Zero Clamp / CLNP: Zero clamping</p> <p>8 / Velocity Limitation / VL, Π: Limits the velocity to parameter value</p> <p>9 / Jog Positive / JOGP: Jog: Moves in positive direction</p> <p>10 / Jog Negative / JOGN: Jog: Moves in negative direction</p> <p>11 / Jog Fast/Slow / JOGF: Jog: Switches between slow and fast movement</p> <p>12 / Gear Ratio Switch / GRRL: Electronic Gear: Switches between two gear ratios</p> <p>19 / Gear Offset 1 / GOF1: Electronic Gear: Adds first gear offset</p> <p>20 / Gear Offset 2 / GOF2: Electronic Gear: Adds second gear offset</p> <p>21 / Reference Switch (REF) / REF: Reference switch</p> <p>22 / Positive Limit Switch (LIMP) / L, ΠP: Positive limit switch</p> <p>23 / Negative Limit Switch (LIMN) / L, Πn: Negative limit switch</p> <p>24 / Switch Controller Parameter Set / CPR: Switches control loop parameter set</p> <p>25 / Inversion AI1 / AI1, V: Inverts analog input AI1</p> <p>26 / Inversion AI2 / AI2, V: Inverts analog input AI2</p> <p>27 / Operating Mode Switch / ΠSWL: Switches operating mode</p> <p>28 / Velocity Controller Integral Off / ENOF: Switches off velocity controller integral term</p> <p>30 / Start Signal Of RMAC / SRΠC: Start signal of relative movement after capture (RMAC)</p> <p>31 / Activate RMAC / RRΠC: Activates the relative movement after capture (RMAC)</p> <p>32 / Activate Operating Mode / RCOP: Activates operating mode</p> <p>40 / Release Holding Brake / REHB: Releases the holding brake</p> <p>Setting can only be modified if power stage is disabled.</p> <p>Modified settings become active the next time the product is powered on.</p>			
<p><i>IOfunct_DI3</i></p> <p><i>CONF → 1 - 3</i></p>	<p>Function Input DI3.</p> <p>1 / Freely Available / NOOE: Available as required</p> <p>2 / Fault Reset / FRE5: Fault reset after error</p> <p>3 / Enable / ENRB: Enables the power stage</p> <p>4 / Halt / HALL: Halt</p> <p>6 / Current Limitation / , L, Π: Limits the current to parameter value</p> <p>7 / Zero Clamp / CLNP: Zero clamping</p> <p>8 / Velocity Limitation / VL, Π: Limits the velocity to parameter value</p> <p>9 / Jog Positive / JOGP: Jog: Moves in positive direction</p>	<p>-</p> <p>-</p> <p>-</p> <p>-</p>	<p>UINT16</p> <p>R/W</p> <p>per.</p> <p>-</p>	<p>Modbus 1800</p>

Parameter name HMI menu HMI name	Description	Unit Minimum value Factory setting Maximum value	Data type R/W Persistent Expert	Parameter address via fieldbus
	<p>10 / Jog Negative / J o G n : Jog: Moves in negative direction</p> <p>11 / Jog Fast/Slow / J o G F : Jog: Switches between slow and fast movement</p> <p>12 / Gear Ratio Switch / G r R E : Electronic Gear: Switches between two gear ratios</p> <p>19 / Gear Offset 1 / G o F 1 : Electronic Gear: Adds first gear offset</p> <p>20 / Gear Offset 2 / G o F 2 : Electronic Gear: Adds second gear offset</p> <p>21 / Reference Switch (REF) / r E F : Reference switch</p> <p>22 / Positive Limit Switch (LIMP) / L , n P : Positive limit switch</p> <p>23 / Negative Limit Switch (LIMN) / L , n n : Negative limit switch</p> <p>24 / Switch Controller Parameter Set / C P R r : Switches control loop parameter set</p> <p>25 / Inversion AI1 / R I , V : Inverts analog input AI1</p> <p>26 / Inversion AI2 / R 2 , V : Inverts analog input AI2</p> <p>27 / Operating Mode Switch / n S w E : Switches operating mode</p> <p>28 / Velocity Controller Integral Off / E n o F : Switches off velocity controller integral term</p> <p>30 / Start Signal Of RMAC / S r n c : Start signal of relative movement after capture (RMAC)</p> <p>31 / Activate RMAC / R r n c : Activates the relative movement after capture (RMAC)</p> <p>32 / Activate Operating Mode / R c o P : Activates operating mode</p> <p>40 / Release Holding Brake / r E h b : Releases the holding brake</p> <p>Setting can only be modified if power stage is disabled.</p> <p>Modified settings become active the next time the product is powered on.</p>			
<p><i>IOfunct_DI4</i></p> <p><i>C o n F → , -</i></p> <p><i>o -</i></p> <p><i>d , 4</i></p>	<p>Function Input DI4.</p> <p>1 / Freely Available / n o n E : Available as required</p> <p>2 / Fault Reset / F r E S : Fault reset after error</p> <p>3 / Enable / E n R b : Enables the power stage</p> <p>4 / Halt / h R L E : Halt</p> <p>6 / Current Limitation / , L , n : Limits the current to parameter value</p> <p>7 / Zero Clamp / C L n P : Zero clamping</p> <p>8 / Velocity Limitation / V L , n : Limits the velocity to parameter value</p> <p>9 / Jog Positive / J o G P : Jog: Moves in positive direction</p> <p>10 / Jog Negative / J o G n : Jog: Moves in negative direction</p> <p>11 / Jog Fast/Slow / J o G F : Jog: Switches between slow and fast movement</p>	<p>-</p> <p>-</p> <p>-</p> <p>-</p>	<p>UINT16</p> <p>R/W</p> <p>per.</p> <p>-</p>	<p>Modbus 1802</p>

Parameter name HMI menu HMI name	Description	Unit Minimum value Factory setting Maximum value	Data type R/W Persistent Expert	Parameter address via fieldbus
	<p>12 / Gear Ratio Switch / G R R E: Electronic Gear: Switches between two gear ratios</p> <p>19 / Gear Offset 1 / G o F 1: Electronic Gear: Adds first gear offset</p> <p>20 / Gear Offset 2 / G o F 2: Electronic Gear: Adds second gear offset</p> <p>21 / Reference Switch (REF) / r E F: Reference switch</p> <p>22 / Positive Limit Switch (LIMP) / L , P: Positive limit switch</p> <p>23 / Negative Limit Switch (LIMN) / L , n: Negative limit switch</p> <p>24 / Switch Controller Parameter Set / C P R r: Switches control loop parameter set</p> <p>25 / Inversion AI1 / R 1 , V: Inverts analog input AI1</p> <p>26 / Inversion AI2 / R 2 , V: Inverts analog input AI2</p> <p>27 / Operating Mode Switch / P S W E: Switches operating mode</p> <p>28 / Velocity Controller Integral Off / E n o F: Switches off velocity controller integral term</p> <p>30 / Start Signal Of RMAC / S r P c: Start signal of relative movement after capture (RMAC)</p> <p>31 / Activate RMAC / R r P c: Activates the relative movement after capture (RMAC)</p> <p>32 / Activate Operating Mode / R c o P: Activates operating mode</p> <p>40 / Release Holding Brake / r E h b: Releases the holding brake</p> <p>Setting can only be modified if power stage is disabled.</p> <p>Modified settings become active the next time the product is powered on.</p>			
<p><i>IOfunct_DI5</i></p> <p><i>C o n F → , -</i></p> <p><i>o -</i></p> <p><i>d , 5</i></p>	<p>Function Input DI5.</p> <p>1 / Freely Available / n o n E: Available as required</p> <p>2 / Fault Reset / F r E S: Fault reset after error</p> <p>3 / Enable / E n A b: Enables the power stage</p> <p>4 / Halt / h A L E: Halt</p> <p>6 / Current Limitation / , L , P: Limits the current to parameter value</p> <p>7 / Zero Clamp / C L P: Zero clamping</p> <p>8 / Velocity Limitation / V L , P: Limits the velocity to parameter value</p> <p>9 / Jog Positive / J o G P: Jog: Moves in positive direction</p> <p>10 / Jog Negative / J o G n: Jog: Moves in negative direction</p> <p>11 / Jog Fast/Slow / J o G F: Jog: Switches between slow and fast movement</p> <p>12 / Gear Ratio Switch / G R R E: Electronic Gear: Switches between two gear ratios</p> <p>19 / Gear Offset 1 / G o F 1: Electronic Gear: Adds first gear offset</p>	<p>-</p> <p>-</p> <p>-</p> <p>-</p>	<p>UINT16</p> <p>R/W</p> <p>per.</p> <p>-</p>	<p>Modbus 1804</p>

Parameter name HMI menu HMI name	Description	Unit Minimum value Factory setting Maximum value	Data type R/W Persistent Expert	Parameter address via fieldbus
	<p>20 / Gear Offset 2 / G O F 2: Electronic Gear: Adds second gear offset</p> <p>21 / Reference Switch (REF) / r E F: Reference switch</p> <p>22 / Positive Limit Switch (LIMP) / L , Π P: Positive limit switch</p> <p>23 / Negative Limit Switch (LIMN) / L , Π n: Negative limit switch</p> <p>24 / Switch Controller Parameter Set / C P R r: Switches control loop parameter set</p> <p>25 / Inversion AI1 / R I , V: Inverts analog input AI1</p> <p>26 / Inversion AI2 / R 2 , V: Inverts analog input AI2</p> <p>27 / Operating Mode Switch / Π S W E: Switches operating mode</p> <p>28 / Velocity Controller Integral Off / E n o F: Switches off velocity controller integral term</p> <p>30 / Start Signal Of RMAC / S r Π c: Start signal of relative movement after capture (RMAC)</p> <p>31 / Activate RMAC / R r Π c: Activates the relative movement after capture (RMAC)</p> <p>32 / Activate Operating Mode / R c o P: Activates operating mode</p> <p>40 / Release Holding Brake / r E h b: Releases the holding brake</p> <p>Setting can only be modified if power stage is disabled.</p> <p>Modified settings become active the next time the product is powered on.</p>			

Parameterization of the Signal Output Functions

Signal Output Function

Various signal output functions can be assigned to the digital signal outputs.

The functions of the inputs and outputs depend on the selected operating mode and the settings of the corresponding parameters.

▲ WARNING
<p>UNINTENDED EQUIPMENT OPERATION</p> <ul style="list-style-type: none"> • Verify that the wiring is appropriate for the factory settings and any subsequent parameterizations. • Only start the system if there are no persons or obstructions in the zone of operation. • Carefully run tests for all operating states and potential error situations when commissioning, upgrading or otherwise modifying the operation of the drive. <p>Failure to follow these instructions can result in death, serious injury, or equipment damage.</p>

In the case of a detected error the state of the signal outputs remains active according to assigned signal output function.

Factory Settings

The table below shows the factory settings of the digital signal outputs depending on the selected operating mode:

Signal	Jog	Electronic Gear	Profile Torque	Profile Velocity
DQ0	No Fault	No Fault	No Fault	No Fault
DQ1	Active	Active	Active	Active
DQ2	In Position Deviation Window	In Position Deviation Window	Current Below Threshold	In Velocity Deviation Window
DQ3	Motor Standstill	Motor Standstill	Motor Standstill	Motor Standstill
DQ4	Selected Error Output	Selected Error Output	Selected Error Output	Selected Error Output

When the operating mode is changed and after the product is powered off and on, the factory settings are assigned to the digital signal inputs and digital signal outputs.

Parameterization

The table below provides an overview of the possible signal output functions depending on the selected operating mode:

Signal output function	Jog	Electronic Gear	Profile Torque	Profile Velocity	Description in section
Freely Available	•	•	•	•	-
No Fault	•	•	•	•	Indication of the Operating State via Signal Inputs, page 205
Active	•	•	•	•	Indication of the Operating State via Signal Inputs, page 205
RMAC Active Or Finished	•	•	•	•	Relative Movement After Capture (RMAC), page 246
In Position Deviation Window	•	•			Position Deviation Window, page 257
In Velocity Deviation Window	•	•		•	Velocity Deviation Window, page 258
Velocity Below Threshold	•	•	•	•	Velocity Threshold Value, page 260
Current Below Threshold	•	•	•	•	Current Threshold Value, page 261
Halt Acknowledge	•	•	•	•	Stopping Movement with Halt, page 237
Motor Standstill	•	•	•	•	Motor Standstill and Direction of Movement, page 256
Selected Error	•	•	•	•	Indicating Error Messages, page 275
Selected Warning	•	•	•	•	Indicating Error Messages, page 275
Motor Moves Positive	•	•	•	•	Motor Standstill and Direction of Movement, page 256
Motor Moves Negative	•	•	•	•	Motor Standstill and Direction of Movement, page 256

The following parameters can be used to parameterize the digital signal outputs:

Parameter name HMI menu HMI name	Description	Unit Minimum value Factory setting Maximum value	Data type R/W Persistent Expert	Parameter address via fieldbus
<i>IOfunct_DQ0</i> <i>CONF → I - 0 -</i> <i>d o 0</i>	<p>Function Output DQ0.</p> <p>1 / Freely Available / n o n E: Available as required</p> <p>2 / No Fault / n F L E: Signals operating states Ready To Switch On, Switched On and Operation Enabled</p> <p>3 / Active / R e E: Signals operating state Operation Enabled</p> <p>4 / RMAC Active Or Finished / r n e R: Relative movement after capture active or finished (RMAC)</p> <p>5 / In Position Deviation Window / i n - P: Position deviation is within window</p> <p>6 / In Velocity Deviation Window / i n - V: Velocity deviation is within window</p> <p>7 / Velocity Below Threshold / v e h r: Motor velocity below threshold</p> <p>8 / Current Below Threshold / i e h r: Motor current below threshold</p> <p>9 / Halt Acknowledge / h a l E: Halt acknowledgement</p> <p>13 / Motor Standstill / n s e d: Motor at a standstill</p> <p>14 / Selected Error / S E r r: One of the specified errors of error classes 1 ... 4 is active</p> <p>16 / Selected Warning / S W r n: One of the specified errors of error class 0 is active</p> <p>22 / Motor Moves Positive / n P o S: Motor moves in positive direction</p> <p>23 / Motor Moves Negative / n n E G: Motor moves in negative direction</p> <p>Setting can only be modified if power stage is disabled.</p> <p>Modified settings become active the next time the product is powered on.</p>	- - - -	<p>UINT16</p> <p>R/W</p> <p>per.</p> <p>-</p>	Modbus 1810
<i>IOfunct_DQ1</i> <i>CONF → I - 0 -</i> <i>d o 1</i>	<p>Function Output DQ1.</p> <p>1 / Freely Available / n o n E: Available as required</p> <p>2 / No Fault / n F L E: Signals operating states Ready To Switch On, Switched On and Operation Enabled</p> <p>3 / Active / R e E: Signals operating state Operation Enabled</p> <p>4 / RMAC Active Or Finished / r n e R: Relative movement after capture active or finished (RMAC)</p> <p>5 / In Position Deviation Window / i n - P: Position deviation is within window</p> <p>6 / In Velocity Deviation Window / i n - V: Velocity deviation is within window</p> <p>7 / Velocity Below Threshold / v e h r: Motor velocity below threshold</p> <p>8 / Current Below Threshold / i e h r: Motor current below threshold</p>	- - - -	<p>UINT16</p> <p>R/W</p> <p>per.</p> <p>-</p>	Modbus 1812

Parameter name HMI menu HMI name	Description	Unit Minimum value Factory setting Maximum value	Data type R/W Persistent Expert	Parameter address via fieldbus
	<p>9 / Halt Acknowledge / HALT: Halt acknowledgement</p> <p>13 / Motor Standstill / Standstill: Motor at a standstill</p> <p>14 / Selected Error / Error: One of the specified errors of error classes 1 ... 4 is active</p> <p>16 / Selected Warning / Warning: One of the specified errors of error class 0 is active</p> <p>22 / Motor Moves Positive / Positive: Motor moves in positive direction</p> <p>23 / Motor Moves Negative / Negative: Motor moves in negative direction</p> <p>Setting can only be modified if power stage is disabled.</p> <p>Modified settings become active the next time the product is powered on.</p>			
IOfuncn_DQ2 Conf → I - O - do 2	<p>Function Output DQ2.</p> <p>1 / Freely Available / None: Available as required</p> <p>2 / No Fault / No Fault: Signals operating states Ready To Switch On, Switched On and Operation Enabled</p> <p>3 / Active / Active: Signals operating state Operation Enabled</p> <p>4 / RMAC Active Or Finished / RMAC: Relative movement after capture active or finished (RMAC)</p> <p>5 / In Position Deviation Window / In - P: Position deviation is within window</p> <p>6 / In Velocity Deviation Window / In - V: Velocity deviation is within window</p> <p>7 / Velocity Below Threshold / Vel thr: Motor velocity below threshold</p> <p>8 / Current Below Threshold / Cur thr: Motor current below threshold</p> <p>9 / Halt Acknowledge / HALT: Halt acknowledgement</p> <p>13 / Motor Standstill / Standstill: Motor at a standstill</p> <p>14 / Selected Error / Error: One of the specified errors of error classes 1 ... 4 is active</p> <p>16 / Selected Warning / Warning: One of the specified errors of error class 0 is active</p> <p>22 / Motor Moves Positive / Positive: Motor moves in positive direction</p> <p>23 / Motor Moves Negative / Negative: Motor moves in negative direction</p> <p>Setting can only be modified if power stage is disabled.</p> <p>Modified settings become active the next time the product is powered on.</p>	- - - -	UINT16 R/W per. -	Modbus 1814

Parameter name HMI menu HMI name	Description	Unit Minimum value Factory setting Maximum value	Data type R/W Persistent Expert	Parameter address via fieldbus
IOfunct_DQ3 Conf → i - o - do3	Function Output DQ3. 1 / Freely Available / n o n E : Available as required 2 / No Fault / n F L E : Signals operating states Ready To Switch On, Switched On and Operation Enabled 3 / Active / R e E : Signals operating state Operation Enabled 4 / RMAC Active Or Finished / r n e R : Relative movement after capture active or finished (RMAC) 5 / In Position Deviation Window / i n - P : Position deviation is within window 6 / In Velocity Deviation Window / i n - V : Velocity deviation is within window 7 / Velocity Below Threshold / v e h r : Motor velocity below threshold 8 / Current Below Threshold / i e h r : Motor current below threshold 9 / Halt Acknowledge / h a l E : Halt acknowledgement 13 / Motor Standstill / n s e d : Motor at a standstill 14 / Selected Error / S E r r : One of the specified errors of error classes 1 ... 4 is active 16 / Selected Warning / S W r n : One of the specified errors of error class 0 is active 22 / Motor Moves Positive / n P o S : Motor moves in positive direction 23 / Motor Moves Negative / n n E G : Motor moves in negative direction Setting can only be modified if power stage is disabled. Modified settings become active the next time the product is powered on.	- - - -	UINT16 R/W per. -	Modbus 1816
IOfunct_DQ4 Conf → i - o - do4	Function Output DQ4. 1 / Freely Available / n o n E : Available as required 2 / No Fault / n F L E : Signals operating states Ready To Switch On, Switched On and Operation Enabled 3 / Active / R e E : Signals operating state Operation Enabled 4 / RMAC Active Or Finished / r n e R : Relative movement after capture active or finished (RMAC) 5 / In Position Deviation Window / i n - P : Position deviation is within window 6 / In Velocity Deviation Window / i n - V : Velocity deviation is within window 7 / Velocity Below Threshold / v e h r : Motor velocity below threshold 8 / Current Below Threshold / i e h r : Motor current below threshold	- - - -	UINT16 R/W per. -	Modbus 1818

Parameter name HMI menu HMI name	Description	Unit Minimum value Factory setting Maximum value	Data type R/W Persistent Expert	Parameter address via fieldbus
	<p>9 / Halt Acknowledge / H A L T : Halt acknowledgement</p> <p>13 / Motor Standstill / M S E D : Motor at a standstill</p> <p>14 / Selected Error / S E R R : One of the specified errors of error classes 1 ... 4 is active</p> <p>16 / Selected Warning / S W R N : One of the specified errors of error class 0 is active</p> <p>22 / Motor Moves Positive / M P O S : Motor moves in positive direction</p> <p>23 / Motor Moves Negative / M N E G : Motor moves in negative direction</p> <p>Setting can only be modified if power stage is disabled.</p> <p>Modified settings become active the next time the product is powered on.</p>			

Parameterization of Software Debouncing

Debounce Time

Signal input debouncing comprises hardware debouncing and software debouncing.

Hardware debounce time is permanently set, see Digital Input Signals 24 V (Hardware switching time), page 37.

When a set signal function is modified, software debouncing is reset to the factory setting on the next power cycle.

The software debounce time can be set via the following parameters.

Parameter name HMI menu HMI name	Description	Unit Minimum value Factory setting Maximum value	Data type R/W Persistent Expert	Parameter address via fieldbus
<i>DI_0_Debounce</i>	Debounce time of DI0. 0 / No: No software debouncing 1 / 0.25 ms: 0.25 ms 2 / 0.50 ms: 0.50 ms 3 / 0.75 ms: 0.75 ms 4 / 1.00 ms: 1.00 ms 5 / 1.25 ms: 1.25 ms 6 / 1.50 ms: 1.50 ms Setting can only be modified if power stage is disabled. Modified settings become active immediately.	- 0 6 6	UINT16 R/W per. -	Modbus 2112
<i>DI_1_Debounce</i>	Debounce time of DI1. 0 / No: No software debouncing 1 / 0.25 ms: 0.25 ms 2 / 0.50 ms: 0.50 ms 3 / 0.75 ms: 0.75 ms 4 / 1.00 ms: 1.00 ms 5 / 1.25 ms: 1.25 ms 6 / 1.50 ms: 1.50 ms Setting can only be modified if power stage is disabled. Modified settings become active immediately.	- 0 6 6	UINT16 R/W per. -	Modbus 2114
<i>DI_2_Debounce</i>	Debounce time of DI2. 0 / No: No software debouncing 1 / 0.25 ms: 0.25 ms 2 / 0.50 ms: 0.50 ms 3 / 0.75 ms: 0.75 ms 4 / 1.00 ms: 1.00 ms 5 / 1.25 ms: 1.25 ms 6 / 1.50 ms: 1.50 ms Setting can only be modified if power stage is disabled. Modified settings become active immediately.	- 0 6 6	UINT16 R/W per. -	Modbus 2116

Parameter name HMI menu HMI name	Description	Unit Minimum value Factory setting Maximum value	Data type R/W Persistent Expert	Parameter address via fieldbus
<i>DI_3_Debounce</i>	Debounce time of DI3. 0 / No: No software debouncing 1 / 0.25 ms: 0.25 ms 2 / 0.50 ms: 0.50 ms 3 / 0.75 ms: 0.75 ms 4 / 1.00 ms: 1.00 ms 5 / 1.25 ms: 1.25 ms 6 / 1.50 ms: 1.50 ms Setting can only be modified if power stage is disabled. Modified settings become active immediately.	- 0 6 6	UINT16 R/W per. -	Modbus 2118
<i>DI_4_Debounce</i>	Debounce time of DI4. 0 / No: No software debouncing 1 / 0.25 ms: 0.25 ms 2 / 0.50 ms: 0.50 ms 3 / 0.75 ms: 0.75 ms 4 / 1.00 ms: 1.00 ms 5 / 1.25 ms: 1.25 ms 6 / 1.50 ms: 1.50 ms Setting can only be modified if power stage is disabled. Modified settings become active immediately.	- 0 6 6	UINT16 R/W per. -	Modbus 2120
<i>DI_5_Debounce</i>	Debounce time of DI5. 0 / No: No software debouncing 1 / 0.25 ms: 0.25 ms 2 / 0.50 ms: 0.50 ms 3 / 0.75 ms: 0.75 ms 4 / 1.00 ms: 1.00 ms 5 / 1.25 ms: 1.25 ms 6 / 1.50 ms: 1.50 ms Setting can only be modified if power stage is disabled. Modified settings become active immediately.	- 0 6 6	UINT16 R/W per. -	Modbus 2122

PTI and PTO Interface

Setting the PTI Interface

Type of Reference Value Signal

A/B signals, P/D signals or CW/CCW signals can be connected to the PTI interface.

Set the type of reference value signal for the PTI interface with the parameter *PTI_signal_type*.

Parameter name	Description	Unit	Data type	Parameter address via fieldbus
HMI menu		Minimum value	R/W	
HMI name		Factory setting	Persistent	
		Maximum value	Expert	
<i>PTI_signal_type</i>	Type of reference value signal for PTI interface.	-	UINT16	Modbus 1284
<i>CONF → P</i>	<p>0 / A/B Signals / AB: Signals ENC_A and ENC_B (quadruple evaluation)</p> <p>1 / P/D Signals / Pd: Signals PULSE and DIR</p> <p>2 / CW/CCW Signals / cWcC: Signals clockwise and counterclockwise</p> <p>Setting can only be modified if power stage is disabled.</p> <p>Modified settings become active the next time the product is powered on.</p>	0 0 2	R/W per. -	

Inverting the Reference Value Signals

The direction of counting of the reference value signals at the PTI interface can be inverted by means of the parameter *InvertDirOfCount*.

Parameter name	Description	Unit	Data type	Parameter address via fieldbus
HMI menu		Minimum value	R/W	
HMI name		Factory setting	Persistent	
		Maximum value	Expert	
<i>InvertDirOfCount</i>	Inversion of direction of counting at PTI interface.	-	UINT16	Modbus 2062
	<p>0 / Inversion Off: Inversion of direction of counting is off</p> <p>1 / Inversion On: Inversion of direction of counting is on</p> <p>Modified settings become active immediately.</p>	0 0 1	R/W per. -	

Setting the Position Value

The position value at the PTI interface can be set manually by means of the parameter *p_PTActSet*.

Parameter name	Description	Unit	Data type	Parameter address via fieldbus
HMI menu		Minimum value	R/W	
HMI name		Factory setting	Persistent	
		Maximum value	Expert	
<i>p_PTI_act_set</i>	Position value at PTI interface. Available with firmware version ≥V01.26.	Inc -2147483648 - 2147483647	INT32 R/W - -	Modbus 2130

Setting the PTO Interface

Type of Usage of PTO Interface

The PTO interface allows you to make reference value signals from the device externally available.

The PTO interface can be used in several ways:

- Encoder simulation based on a position value
- Encoder simulation based on reference current
- PTI signal

The parameter *PTO_mode* lets you set the way the PTO interface is used.

Parameter name	Description	Unit	Data type	Parameter address via fieldbus
HMI menu		Minimum value	R/W	
HMI name		Factory setting	Persistent	
		Maximum value	Expert	
<i>PTO_mode</i>	Type of usage of PTO interface. 0 / Off: PTO interface disabled 1 / Esim pAct Enc 1: Encoder simulation based on actual position of encoder 1 2 / Esim pRef: Encoder simulation based on reference position (<i>_p_ref</i>) 3 / PTI Signal: Directly the signal from PTI interface 5 / Esim iqRef: Encoder simulation based on reference current Setting can only be modified if power stage is disabled. Modified settings become active the next time the power stage is enabled.	- 0 1 5	UINT16 R/W per. -	Modbus 1342

Encoder Simulation Based on a Position Value

The following types of encoder simulation based on a position value are possible:

- Encoder simulation based on actual position of encoder 1
- Encoder simulation based on the reference position values (*_p_ref*)

The resolution for the encoder simulation is set with the parameter *ESIM_scale*.

Parameter name	Description	Unit	Data type	Parameter address via fieldbus
HMI menu		Minimum value	R/W	
HMI name		Factory setting	Persistent	
		Maximum value	Expert	
<i>ESIM_scale</i>	Resolution of encoder simulation.	Enclnc	UINT16	Modbus 1322
<i>CONF → 1 - 0 -</i> <i>ESSC</i>	Resolution defines the number of increments per revolution (AB signal with quadruple evaluation). The index pulse is created once per revolution at an interval where signal A and signal B are high. Setting can only be modified if power stage is disabled. Modified settings become active the next time the product is powered on.	8 4096 65535	R/W per. -	

With firmware version $\geq V01.10$, you can set the resolution with decimal places.

The parameter *ESIM_HighResolution* lets you set the resolution with decimal places.

Parameter name	Description	Unit	Data type	Parameter address via fieldbus
HMI menu		Minimum value	R/W	
HMI name		Factory setting	Persistent	
		Maximum value	Expert	
<i>ESIM_HighResolution</i>	Encoder simulation: High resolution. Specifies the number of increments per revolution with 12 bit decimal places. If the parameter is set to a multiple of 4096, the index pulse will be generated exactly at the same position within one revolution. The setting of parameter <i>ESIM_scale</i> is only used if parameter <i>ESIM_HighResolution</i> is set to 0. Otherwise, the setting of <i>ESIM_HighResolution</i> is used. Example: 1417.322835 encoder simulation pulses per revolution are required. Set the parameter to $1417.322835 * 4096 = 5805354$. In this example, the index pulse will be generated exactly after every 1417 pulses. This means that the index pulse shifts with each revolution. Setting can only be modified if power stage is disabled. Modified settings become active the next time the product is powered on.	Enclnc 0 0 268431360	UINT32 R/W per. expert	Modbus 1380

With firmware version $\geq V01.10$, you can set a phase shift of the encoder simulation.

The phase shift of the encoder simulation is set with the parameter *ESIM_PhaseShift*.

Parameter name	Description	Unit	Data type	Parameter address via fieldbus
HMI menu		Minimum value	R/W	
HMI name		Factory setting	Persistent	
		Maximum value	Expert	
<i>ESIM_PhaseShift</i>	Encoder simulation: Phase shift for pulse output. The generated encoder simulation pulses can be shifted in units of 1/4096 encoder pulses. The shift results in a position offset at PTO. The index pulse is shifted as well. Modified settings become active immediately. Available with firmware version \geq V01.10.	- -32768 0 32767	INT16 R/W - expert	Modbus 1382

Encoder Simulation Based on Reference Current

In the case of encoder simulation based on the reference current, A/B signals are output. The maximum frequency of the A/B signals is $1.6 * 10^{-6}$ increments per second and corresponds to the maximum reference current (value in parameter *CTRL_I_max*).

With firmware version \geq V01.20, you can set encoder simulation based on the reference current.

PTI Signal

If the PTI signal is selected by means of parameter *PTO_mode*, the signal from the PTI interface is directly made available at the PTO interface.

Switching Between Control Loop Parameter Sets

Overview of the Controller Structure

General

The illustration below provides an overview of the controller structure.

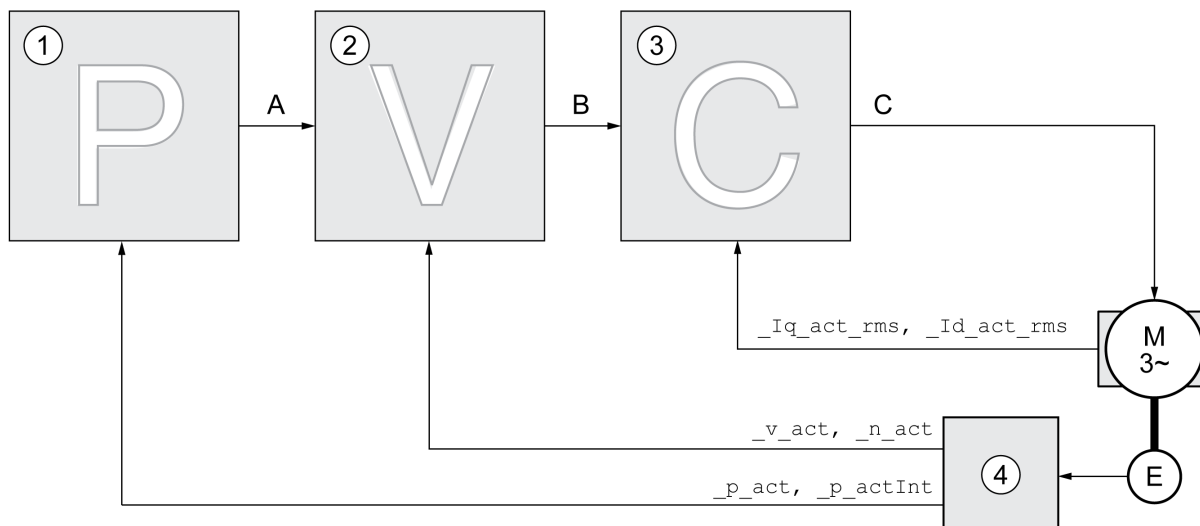

1 Position controller

2 Velocity controller

3 Current controller

4 Encoder evaluation

Position Controller

The position controller reduces the difference between the reference position and the actual position of the motor (position deviation) to a minimum. When the motor is at a standstill, the position deviation is close to zero in the case of a well-tuned position controller.

An optimized velocity control loop is a prerequisite for good amplification of the position controller.

Velocity Controller

The velocity controller controls the motor velocity by varying the motor current depending on the load situation. The velocity controller has a decisive influence on the dynamic response of the drive. The dynamics of the velocity controller depend on:

- Moment of inertia of the drive and the controlled system
- Power of the motor
- Stiffness and elasticity of the elements in the flow of forces
- Backlash of the drive elements
- Friction

Current Controller

The current controller determines the torque of the motor. The current controller is automatically optimally tuned with the stored motor data.

Overview of Position Controller

Overview

The illustration below provides an overview of the position controller.

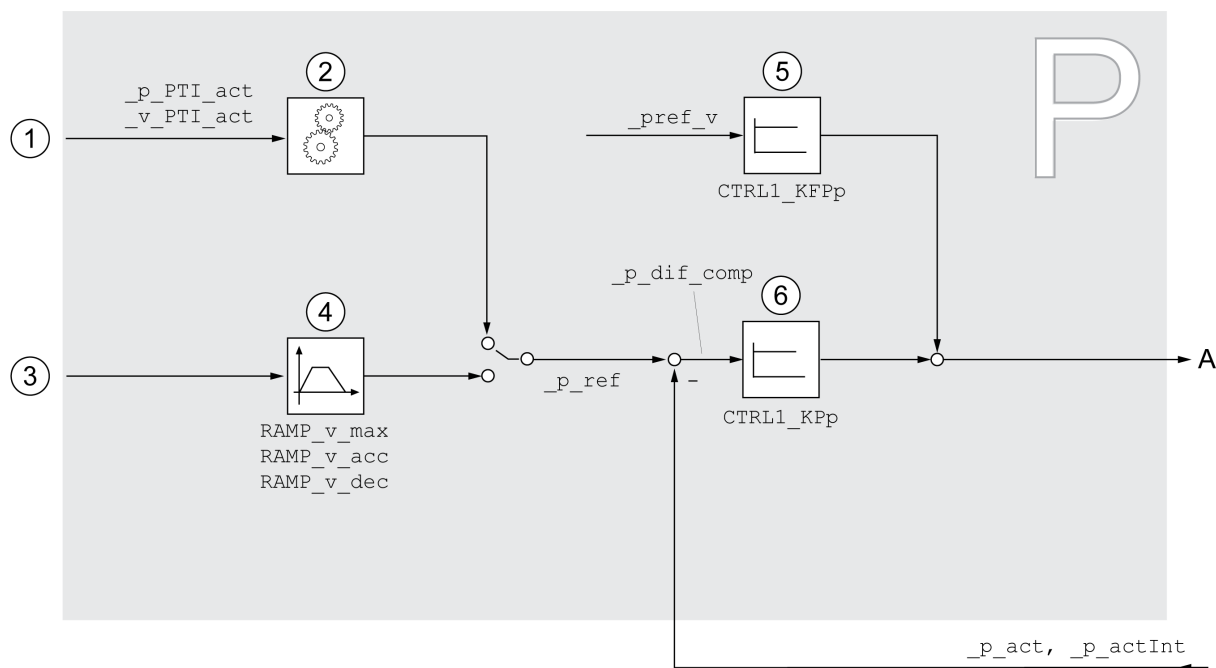

- 1 Reference value signals for the operating mode Electronic Gear (position synchronization)
- 2 Evaluation of the reference value signal for the operating mode Electronic Gear
- 3 Target values for the operating mode Jog
- 4 Motion profile for the velocity
- 5 Velocity feed-forward control
- 6 Position controller

Sampling Period

The sampling period of the position controller is 250 μ s.

Overview of Velocity Controller

Overview

The illustration below provides an overview of the velocity controller.

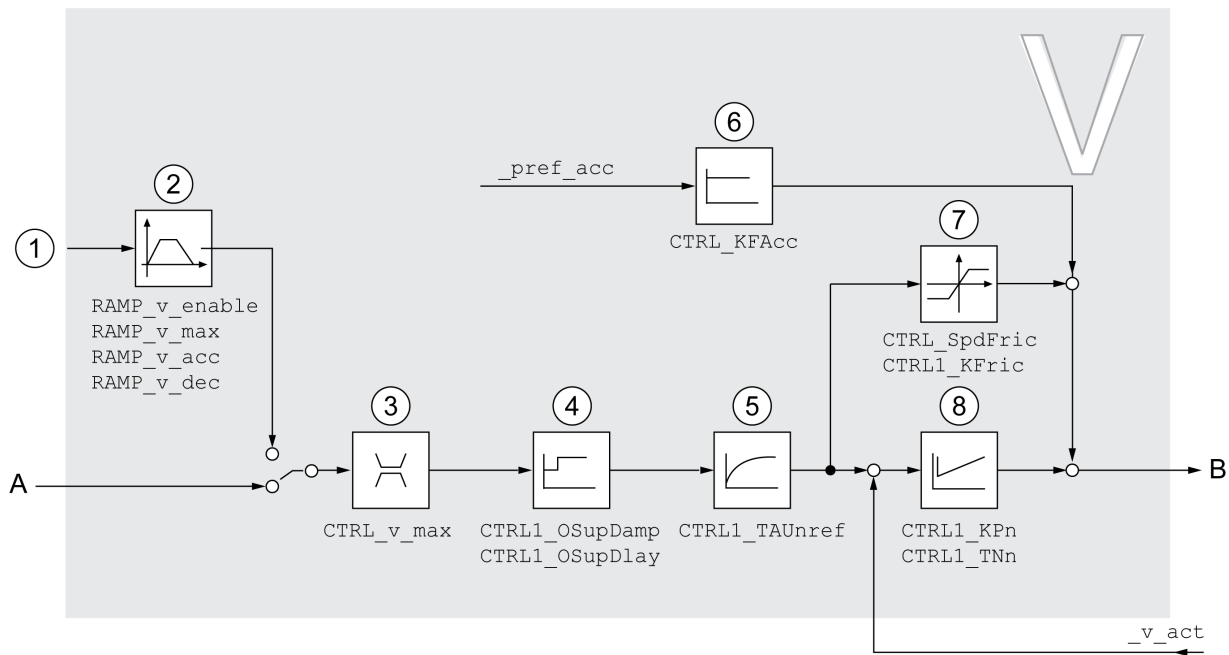

- 1 Reference value signals for the operating mode Electronic Gear with the method "Velocity Synchronization" and target values for the operating mode Profile Velocity
- 2 Motion profile for the velocity
- 3 Velocity limitation
- 4 Overshoot suppression filter (parameter accessible in Expert mode)
- 5 Filter time constant of the reference velocity value filter
- 6 Acceleration feed forward control (parameter accessible in Expert mode)
- 7 Friction compensation (parameter accessible in Expert mode)
- 8 Velocity Loop Controller

Sampling Period

The sampling period of the velocity controller is 62.5 μs.

Overview of Current Controller

Overview

The illustration below provides an overview of the current controller.

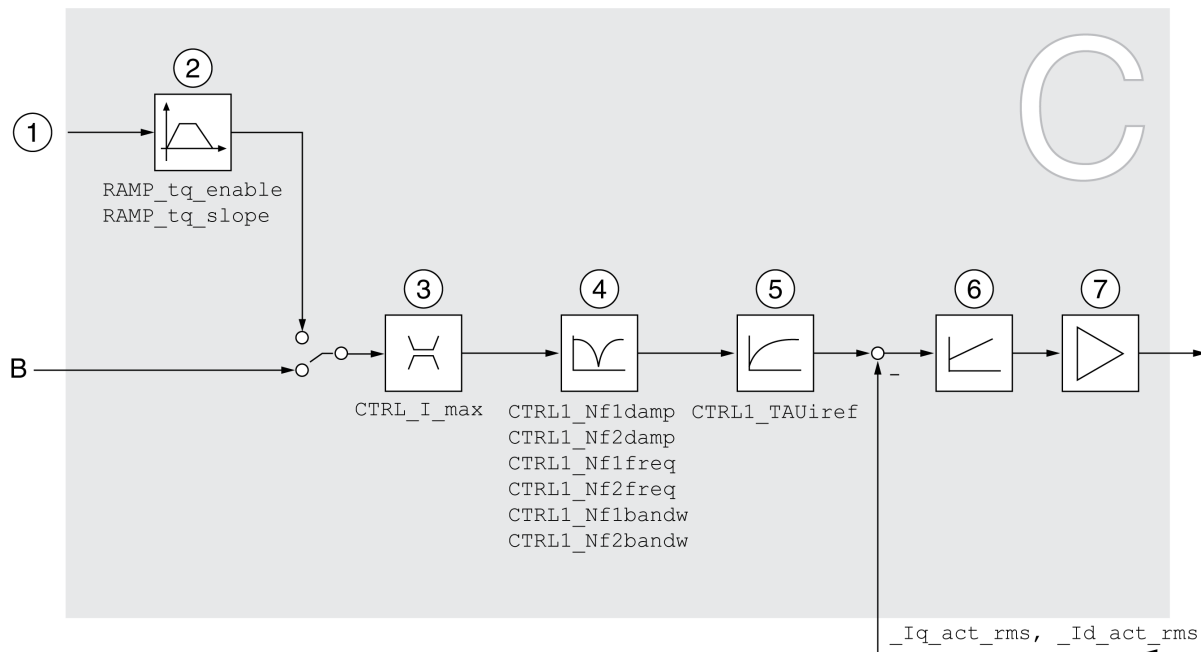

- 1 Target values for the operating mode Profile Torque
- 2 Motion profile for the torque
- 3 Current limitation
- 4 Notch filter (parameter accessible in Expert mode)
- 5 Filter time constant of the reference current value filter
- 6 Current controller
- 7 Power stage

Sampling Period

The sampling period of the current controller is 62.5 μ s.

Parameterizable Control Loop Parameters

Control Loop Parameter Set

The product features 2 control loop parameter sets that can be parameterized separately. The values for the control loop parameters determined during autotuning are stored in control loop parameter set 1.

A control loop parameter set consists of freely accessible parameters and parameters which are only accessible in Expert mode.

Control loop parameter set 1	Control loop parameter set 2
Freely accessible parameters:	Freely accessible parameters:
<i>CTRL1_KPn</i>	<i>CTRL2_KPn</i>
<i>CTRL1_TNn</i>	<i>CTRL2_TNn</i>
<i>CTRL1_KPp</i>	<i>CTRL2_KPp</i>
<i>CTRL1_TAUiref</i>	<i>CTRL2_TAUiref</i>
<i>CTRL1_TAUUnref</i>	<i>CTRL2_TAUUnref</i>
<i>CTRL1_KFPp</i>	<i>CTRL2_KFPp</i>
Parameters only accessible in expert mode:	Parameters only accessible in expert mode:
<i>CTRL1_Nf1damp</i>	<i>CTRL2_Nf1damp</i>
<i>CTRL1_Nf1freq</i>	<i>CTRL2_Nf1freq</i>
<i>CTRL1_Nf1bandw</i>	<i>CTRL2_Nf1bandw</i>
<i>CTRL1_Nf2damp</i>	<i>CTRL2_Nf2damp</i>
<i>CTRL1_Nf2freq</i>	<i>CTRL2_Nf2freq</i>
<i>CTRL1_Nf2bandw</i>	<i>CTRL2_Nf2bandw</i>
<i>CTRL1_Osupdamp</i>	<i>CTRL2_Osupdamp</i>
<i>CTRL1_Osupdelay</i>	<i>CTRL2_Osupdelay</i>
<i>CTRL1_Kfric</i>	<i>CTRL2_Kfric</i>

See sections Control Loop Parameter Set 1, page 197 and Control Loop Parameter Set 2, page 199.

Parameterization

- Selecting a control loop parameter set
Select a control loop parameter set after switching on.
See [Selecting a Control Loop Parameter Set](#), page 192.
- Automatically switching between control loop parameter sets
It is possible to switch between the two control loop parameter sets.
See [Automatically Switching Between Control Loop Parameter Sets](#), page 193.
- Copying a control loop parameter set
The values of control loop parameter set 1 can be copied to control loop parameter set 2.
See [Copying a Control Loop Parameter Set](#), page 196.
- Deactivating the integral term
The integral term and, by implication, the integral action time, can be deactivated via a digital signal input.
See [Deactivating the Integral Term](#), page 197.

Selecting a Control Loop Parameter Set

Description

The active control loop parameter set is indicated via the parameter *_CTRL_ActParSet*.

The parameter *CTRL_PwrUpParSet* allows you to set the control loop parameter set to be activated after powering on. Alternatively, you can set whether or not the product is to switch automatically between the two control loop parameter sets.

The parameter *CTRL_SelParSet* allows you to switch between the two control loop parameter sets during operation.

Parameter name HMI menu HMI name	Description	Unit Minimum value Factory setting Maximum value	Data type R/W Persistent Expert	Parameter address via fieldbus
<i>_CTRL_ActParSet</i>	Active control loop parameter set. Value 1: Control loop parameter set 1 is active Value 2: Control loop parameter set 2 is active A control loop parameter set is active after the time for the parameter switching (<i>CTRL_ParChgTime</i>) has elapsed.	- - - -	UINT16 R/- - -	Modbus 4398
<i>CTRL_PwrUpParSet</i>	Selection of control loop parameter set at power up. 0 / Switching Condition: The switching condition is used for control loop parameter set switching 1 / Parameter Set 1: Control loop parameter set 1 is used 2 / Parameter Set 2: Control loop parameter set 2 is used The selected value is also written to <i>CTRL_SelParSet</i> (non-persistent). Modified settings become active immediately.	- 0 1 2	UINT16 R/W per. -	Modbus 4400
<i>CTRL_SelParSet</i>	Selection of control loop parameter set. Coding see parameter: <i>CTRL_PwrUpParSet</i> Modified settings become active immediately.	- 0 1 2	UINT16 R/W - -	Modbus 4402

Automatically Switching Between Control Loop Parameter Sets

Description

It is possible to automatically switch between the two control loop parameter sets.

The following criteria can be set for switching between the control loop parameter sets:

- Digital signal input
- Position deviation window
- Target velocity below parameterizable value
- Actual velocity below parameterizable value

Settings

The illustration below provides an overview of switching between the parameter sets.

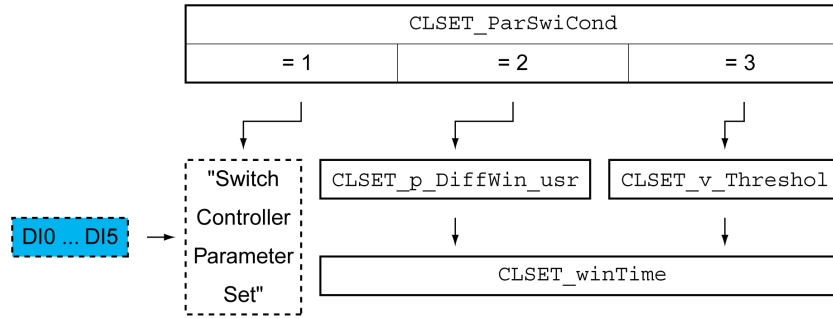

Time Chart

The freely accessible parameters are changed linearly. This linear change of the values of control loop parameter set 1 to the values of control loop parameter set 2 takes place during the parameterizable time *CTRL_ParChgTime*.

The parameters only accessible in Expert mode are directly changed to the values of the other control loop parameter set after the parameterizable time *CTRL_ParChgTime* has passed.

The figure below shows the time chart for switching the control loop parameters.

Time chart for switching the control loop parameter sets

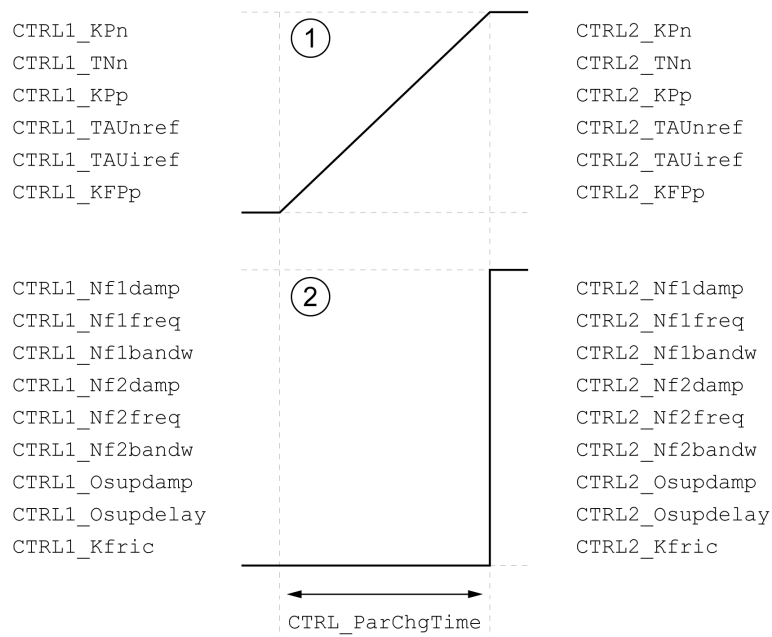

1 Freely accessible parameters are changed linearly over time

2 Parameters which are only accessible in Expert mode are switched over directly

Parameter name HMI menu HMI name	Description	Unit Minimum value Factory setting Maximum value	Data type R/W Persistent Expert	Parameter address via fieldbus
<i>CLSET_ParSwiCond</i>	<p>Condition for parameter set switching.</p> <p>0 / None Or Digital Input: None or digital input function selected</p> <p>1 / Inside Position Deviation: Inside position deviation (value definition in parameter CLSET_p_DiffWin)</p> <p>2 / Below Reference Velocity: Below reference velocity (value definition in parameter CLSET_v_Threshold)</p> <p>3 / Below Actual Velocity: Below actual velocity (value definition in parameter CLSET_v_Threshold)</p> <p>4 / Reserved: Reserved</p> <p>In the case of parameter set switching, the values of the following parameters are changed gradually:</p> <ul style="list-style-type: none"> - CTRL_KPn - CTRL_TNn - CTRL_KPp - CTRL_TAUref - CTRL_TAUiref - CTRL_KFPp <p>The following parameters are changed immediately after the time for parameter set switching (CTRL_ParChgTime):</p> <ul style="list-style-type: none"> - CTRL_Nf1damp - CTRL_Nf1freq - CTRL_Nf1bandw - CTRL_Nf2damp - CTRL_Nf2freq - CTRL_Nf2bandw - CTRL_Osupdamp - CTRL_Osupdelay - CTRL_Kfric <p>Modified settings become active immediately.</p>	<p>-</p> <p>0</p> <p>0</p> <p>4</p>	<p>UINT16</p> <p>R/W</p> <p>per.</p> <p>-</p>	<p>Modbus 4404</p>
<i>CLSET_p_DiffWin_usr</i>	<p>Position deviation for control loop parameter set switching.</p> <p>If the position deviation of the position controller is less than the value of this parameter, control loop parameter set 2 is used. Otherwise, control loop parameter set 1 is used.</p> <p>The minimum value, the factory setting and the maximum value depend on the scaling factor.</p> <p>Modified settings become active immediately.</p> <p>Available with firmware version ≥V01.05.</p>	<p>usr_p</p> <p>0</p> <p>164</p> <p>2147483647</p>	<p>INT32</p> <p>R/W</p> <p>per.</p> <p>-</p>	<p>Modbus 4426</p>

Parameter name	Description	Unit	Data type	Parameter address via fieldbus
HMI menu		Minimum value	R/W	
HMI name		Factory setting	Persistent	
		Maximum value	Expert	
<i>CLSET_v_Threshol</i>	Velocity threshold for control loop parameter set switching. If the reference velocity or the actual velocity are less than the value of this parameter, control loop parameter set 2 is used. Otherwise, control loop parameter set 1 is used. Modified settings become active immediately.	usr_v 0 50 2147483647	UINT32 R/W per. -	Modbus 4410
<i>CLSET_winTime</i>	Time window for parameter set switching. Value 0: Window monitoring deactivated. Value >0: Window time for the parameters <i>CLSET_v_Threshol</i> and <i>CLSET_p_DiffWin</i> . Modified settings become active immediately.	ms 0 0 1000	UINT16 R/W per. -	Modbus 4406
<i>CTRL_ParChgTime</i>	Period of time for control loop parameter set switching. In the case of control loop parameter set switching, the values of the following parameters are changed linearly: - <i>CTRL_KPn</i> - <i>CTRL_TNn</i> - <i>CTRL_KPp</i> - <i>CTRL_TAUref</i> - <i>CTRL_TAUiref</i> - <i>CTRL_KFPp</i> Modified settings become active immediately.	ms 0 0 2000	UINT16 R/W per. -	Modbus 4392

Copying a Control Loop Parameter Set

Description

The parameter *CTRL_ParSetCopy* allows you to copy the values of control loop parameter set 1 to control loop parameter set 2 or the values of control loop parameter set 2 to control loop parameter set 1.

Parameter name	Description	Unit	Data type	Parameter address via fieldbus
HMI menu		Minimum value	R/W	
HMI name		Factory setting	Persistent	
		Maximum value	Expert	
<i>CTRL_ParSetCopy</i>	Control loop parameter set copying. Value 1: Copy control loop parameter set 1 to set 2 Value 2: Copy control loop parameter set 2 to set 1 If control loop parameter set 2 is copied to control loop parameter set 1, the parameter <i>CTRL_GlobGain</i> is set to 100%. Modified settings become active immediately.	- 0.0 - 0.2	UINT16 R/W - -	Modbus 4396

Deactivating the Integral Term

Description

The integral term of the velocity controller can be deactivated via the signal input function "Velocity Controller Integral Off". If the integral term is deactivated, the integral action time of the velocity controller (*CTRL1_TNn* and *CTRL2_TNn*) is implicitly and gradually reduced to zero. The time it takes to reduce the value to zero depends on the parameter *CTRL_ParChgTime*. In the case of vertical axes, the integral term is needed to reduce position deviations during standstill.

Control Loop Parameter Set 1

Overview

Parameter name HMI menu HMI name	Description	Unit Minimum value Factory setting Maximum value	Data type R/W Persistent Expert	Parameter address via fieldbus
<i>CTRL1_KPn</i> <i>CONF → drC - PnI</i>	Velocity controller P gain. The default value is calculated on the basis of the motor parameters. In the case of switching between the two control loop parameter sets, the values are changed linearly over the time defined in the parameter <i>CTRL_ParChgTime</i> . In increments of 0.0001 A/RPM. Modified settings become active immediately.	A/RPM 0.0001 - 2.5400	UINT16 R/W per. -	Modbus 4610
<i>CTRL1_TNn</i> <i>CONF → drC - EinI</i>	Velocity controller integral action time. The default value is calculated. In the case of switching between the two control loop parameter sets, the values are changed linearly over the time defined in the parameter <i>CTRL_ParChgTime</i> . In increments of 0.01 ms. Modified settings become active immediately.	ms 0.00 - 327.67	UINT16 R/W per. -	Modbus 4612
<i>CTRL1_KPp</i> <i>CONF → drC - PP I</i>	Position controller P gain. The default value is calculated. In the case of switching between the two control loop parameter sets, the values are changed linearly over the time defined in the parameter <i>CTRL_ParChgTime</i> . In increments of 0.1 1/s. Modified settings become active immediately.	1/s 2.0 - 900.0	UINT16 R/W per. -	Modbus 4614
<i>CTRL1_TAUiref</i>	Filter time constant of the reference current value filter. In the case of switching between the two control loop parameter sets, the values are changed linearly over the time defined in the parameter <i>CTRL_ParChgTime</i> . In increments of 0.01 ms. Modified settings become active immediately.	ms 0.00 0.50 4.00	UINT16 R/W per. -	Modbus 4618

Parameter name HMI menu HMI name	Description	Unit Minimum value Factory setting Maximum value	Data type R/W Persistent Expert	Parameter address via fieldbus
<i>CTRL1_TAUnref</i> <i>ConF → drC -</i> <i>TRU I</i>	Filter time constant of the reference velocity value filter. In the case of switching between the two control loop parameter sets, the values are changed linearly over the time defined in the parameter CTRL_ParChgTime. In increments of 0.01 ms. Modified settings become active immediately.	ms 0.00 9.00 327.67	UINT16 R/W per. -	Modbus 4616
<i>CTRL1_KFPP</i> <i>ConF → drC -</i> <i>FPP I</i>	Velocity feed-forward control. In the case of switching between the two control loop parameter sets, the values are changed linearly over the time defined in the parameter CTRL_ParChgTime. In increments of 0.1 %. Modified settings become active immediately.	% 0.0 0.0 200.0	UINT16 R/W per. -	Modbus 4620
<i>CTRL1_Nf1damp</i>	Notch filter 1: Damping. In increments of 0.1 %. Modified settings become active immediately.	% 55.0 90.0 99.0	UINT16 R/W per. expert	Modbus 4624
<i>CTRL1_Nf1freq</i>	Notch filter 1: Frequency. The filter is deactivated at a value of 15000. In increments of 0.1 Hz. Modified settings become active immediately.	Hz 50.0 1500.0 1500.0	UINT16 R/W per. expert	Modbus 4626
<i>CTRL1_Nf1bandw</i>	Notch filter 1: Bandwidth. Definition of bandwidth: $1 - F_b/F_0$ In increments of 0.1 %. Modified settings become active immediately.	% 1.0 70.0 90.0	UINT16 R/W per. expert	Modbus 4628
<i>CTRL1_Nf2damp</i>	Notch filter 2: Damping. In increments of 0.1 %. Modified settings become active immediately.	% 55.0 90.0 99.0	UINT16 R/W per. expert	Modbus 4630
<i>CTRL1_Nf2freq</i>	Notch filter 2: Frequency. The filter is deactivated at a value of 15000. In increments of 0.1 Hz. Modified settings become active immediately.	Hz 50.0 1500.0 1500.0	UINT16 R/W per. expert	Modbus 4632
<i>CTRL1_Nf2bandw</i>	Notch filter 2: Bandwidth. Definition of bandwidth: $1 - F_b/F_0$ In increments of 0.1 %. Modified settings become active immediately.	% 1.0 70.0 90.0	UINT16 R/W per. expert	Modbus 4634
<i>CTRL1_Osupdamp</i>	Overshoot suppression filter: Damping. The filter is deactivated at a value of 0. In increments of 0.1 %. Modified settings become active immediately.	% 0.0 0.0 50.0	UINT16 R/W per. expert	Modbus 4636

Parameter name HMI menu HMI name	Description	Unit Minimum value Factory setting Maximum value	Data type R/W Persistent Expert	Parameter address via fieldbus
<i>CTRL1_Osupdelay</i>	Overshoot suppression filter: Time delay. The filter is deactivated at a value of 0. In increments of 0.01 ms. Modified settings become active immediately.	ms 0.00 0.00 75.00	UINT16 R/W per. expert	Modbus 4638
<i>CTRL1_Kfric</i>	Friction compensation: Gain. In increments of 0.01 A _{rms} . Modified settings become active immediately.	A _{rms} 0.00 0.00 10.00	UINT16 R/W per. expert	Modbus 4640

Control Loop Parameter Set 2

Overview

Parameter name HMI menu HMI name	Description	Unit Minimum value Factory setting Maximum value	Data type R/W Persistent Expert	Parameter address via fieldbus
<i>CTRL2_KPn</i> <i>CONF → dr C - Pn 2</i>	Velocity controller P gain. The default value is calculated on the basis of the motor parameters. In the case of switching between the two control loop parameter sets, the values are changed linearly over the time defined in the parameter CTRL_ParChgTime. In increments of 0.0001 A/RPM. Modified settings become active immediately.	A/RPM 0.0001 - 2.5400	UINT16 R/W per. -	Modbus 4866
<i>CTRL2_TNn</i> <i>CONF → dr C - Tn 2</i>	Velocity controller integral action time. The default value is calculated. In the case of switching between the two control loop parameter sets, the values are changed linearly over the time defined in the parameter CTRL_ParChgTime. In increments of 0.01 ms. Modified settings become active immediately.	ms 0.00 - 327.67	UINT16 R/W per. -	Modbus 4868
<i>CTRL2_KPp</i> <i>CONF → dr C - Pp 2</i>	Position controller P gain. The default value is calculated. In the case of switching between the two control loop parameter sets, the values are changed linearly over the time defined in the parameter CTRL_ParChgTime. In increments of 0.1 1/s. Modified settings become active immediately.	1/s 2.0 - 900.0	UINT16 R/W per. -	Modbus 4870

Parameter name HMI menu HMI name	Description	Unit Minimum value Factory setting Maximum value	Data type R/W Persistent Expert	Parameter address via fieldbus
<i>CTRL2_TAUiref</i>	Filter time constant of the reference current value filter. In the case of switching between the two control loop parameter sets, the values are changed linearly over the time defined in the parameter CTRL_ParChgTime. In increments of 0.01 ms. Modified settings become active immediately.	ms 0.00 0.50 4.00	UINT16 R/W per. -	Modbus 4874
<i>CTRL2_TAUref</i> <i>ConF → drC -</i> <i>LRU?</i>	Filter time constant of the reference velocity value filter. In the case of switching between the two control loop parameter sets, the values are changed linearly over the time defined in the parameter CTRL_ParChgTime. In increments of 0.01 ms. Modified settings become active immediately.	ms 0.00 9.00 327.67	UINT16 R/W per. -	Modbus 4872
<i>CTRL2_KFPp</i> <i>ConF → drC -</i> <i>FPP?</i>	Velocity feed-forward control. In the case of switching between the two control loop parameter sets, the values are changed linearly over the time defined in the parameter CTRL_ParChgTime. In increments of 0.1 %. Modified settings become active immediately.	% 0.0 0.0 200.0	UINT16 R/W per. -	Modbus 4876
<i>CTRL2_Nf1damp</i>	Notch filter 1: Damping. In increments of 0.1 %. Modified settings become active immediately.	% 55.0 90.0 99.0	UINT16 R/W per. expert	Modbus 4880
<i>CTRL2_Nf1freq</i>	Notch filter 1: Frequency. The filter is deactivated at a value of 15000. In increments of 0.1 Hz. Modified settings become active immediately.	Hz 50.0 1500.0 1500.0	UINT16 R/W per. expert	Modbus 4882
<i>CTRL2_Nf1bandw</i>	Notch filter 1: Bandwidth. Definition of bandwidth: $1 - Fb/F0$ In increments of 0.1 %. Modified settings become active immediately.	% 1.0 70.0 90.0	UINT16 R/W per. expert	Modbus 4884
<i>CTRL2_Nf2damp</i>	Notch filter 2: Damping. In increments of 0.1 %. Modified settings become active immediately.	% 55.0 90.0 99.0	UINT16 R/W per. expert	Modbus 4886
<i>CTRL2_Nf2freq</i>	Notch filter 2: Frequency. The filter is deactivated at a value of 15000. In increments of 0.1 Hz. Modified settings become active immediately.	Hz 50.0 1500.0 1500.0	UINT16 R/W per. expert	Modbus 4888

Parameter name HMI menu HMI name	Description	Unit Minimum value Factory setting Maximum value	Data type R/W Persistent Expert	Parameter address via fieldbus
<i>CTRL2_Nf2bandw</i>	Notch filter 2: Bandwidth. Definition of bandwidth: $1 - F_b/F_0$ In increments of 0.1 %. Modified settings become active immediately.	% 1.0 70.0 90.0	UINT16 R/W per. expert	Modbus 4890
<i>CTRL2_Osupdamp</i>	Overshoot suppression filter: Damping. The filter is deactivated at a value of 0. In increments of 0.1 %. Modified settings become active immediately.	% 0.0 0.0 50.0	UINT16 R/W per. expert	Modbus 4892
<i>CTRL2_Osupdelay</i>	Overshoot suppression filter: Time delay. The filter is deactivated at a value of 0. In increments of 0.01 ms. Modified settings become active immediately.	ms 0.00 0.00 75.00	UINT16 R/W per. expert	Modbus 4894
<i>CTRL2_Kfric</i>	Friction compensation: Gain. In increments of 0.01 A_{rms} . Modified settings become active immediately.	A_{rms} 0.00 0.00 10.00	UINT16 R/W per. expert	Modbus 4896

Operating States and Operating Modes

Operating States

State Diagram and State Transitions

State Diagram

When the product is powered on and when an operating mode is started, the product goes through a number of operating states.

The state diagram (state machine) shows the relationships between the operating states and the state transitions.

The operating states are internally monitored and influenced by monitoring functions.

Motor without current

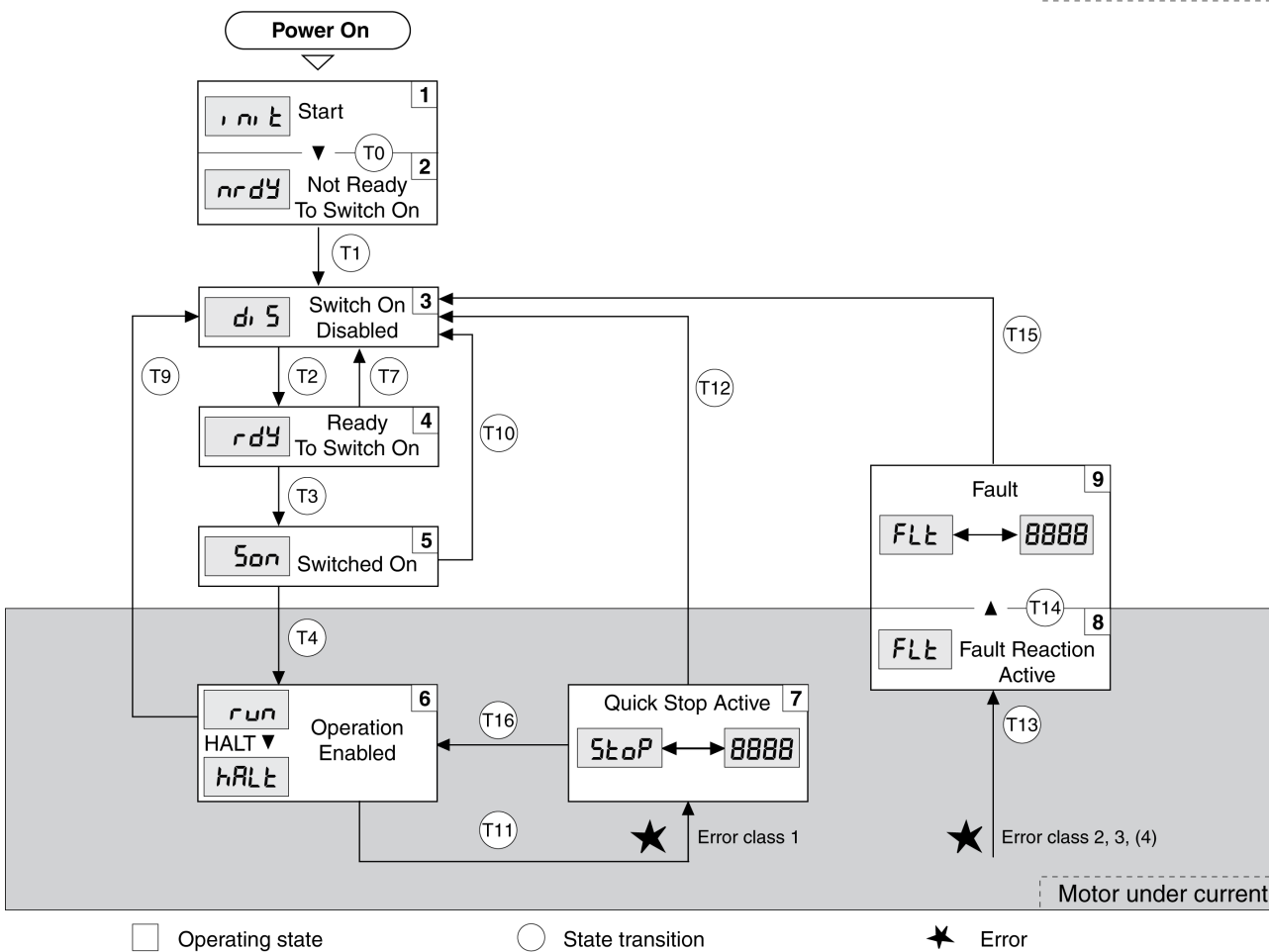

Operating States

Operating state	Description
1 Start	Electronics are initialized
2 Not Ready To Switch On	The power stage is not ready to switch on
3 Switch On Disabled	Impossible to enable the power stage
4 Ready To Switch On	The power stage is ready to switch on.
5 Switched On	Power stage is switched on
6 Operation Enabled	Power stage is enabled

Operating state	Description
	Selected operating mode is active
7 Quick Stop Active	"Quick Stop" is being executed
8 Fault Reaction Active	Error response is active
9 Fault	Error response terminated Power stage is disabled

Error Class

The errors are classified according to the following error classes:

Error class	State transition	Error response	Resetting an error message
0	-	No interruption of the movement	Function "Fault Reset"
1	T11	Stop movement with "Quick Stop"	Function "Fault Reset"
2	T13, T14	Stop movement with "Quick Stop" and disable the power stage when the motor has come to a standstill	Function "Fault Reset"
3	T13, T14	Disable the power stage immediately without stopping the movement first	Function "Fault Reset"
4	T13, T14	Disable the power stage immediately without stopping the movement first	Power cycle

Error Response

The state transition T13 (error class 2, 3 or 4) initiates an error response as soon as an internal occurrence signals an error to which the device must react.

Error class	Response
2	Movement is stopped with "Quick Stop" Holding brake is applied Power stage is disabled
3, 4 or Safety function STO	Power stage is immediately disabled

An error can be triggered by a temperature sensor, for example. The drive cancels the movement and triggers an error response. Subsequently, the operating state changes to 9 Fault.

Resetting an Error Message

A "Fault Reset" resets an error message.

In the event of a "Quick Stop" triggered by a detected error of class 1 (operating state 7 Quick Stop Active), a "Fault Reset" causes a direct transition to operating state 6 Operation Enabled.

State Transitions

State transitions are triggered by an input signal, a fieldbus command or as a response to a monitoring function.

State transition	Operating state	Condition / event ⁽¹⁾	Response
T0	1-> 2	• Device electronics successfully initialized	
T1	2-> 3	• Parameter successfully initialized	

State transition	Operating state	Condition / event ⁽¹⁾	Response
T2	3 -> 4	<ul style="list-style-type: none"> No undervoltage and Encoder successfully checked and Actual velocity: <1000 RPM and STO signals = +24V 	
T3	4 -> 5	<ul style="list-style-type: none"> Request for enabling the power stage 	
T4	5 -> 6	<ul style="list-style-type: none"> Automatic transition 	Power stage is enabled. User parameters are checked. Holding brake is released (if available).
T7	4 -> 3	<ul style="list-style-type: none"> Undervoltage STO signals = 0V Actual velocity: >1000 RPM (for example by external driving force) 	-
T9	6 -> 3	<ul style="list-style-type: none"> Request for disabling the power stage 	Movement is canceled with "Halt" or power stage is immediately disabled. Can be set via parameter <i>DSM_ShutDownOption</i> .
T10	5 -> 3	<ul style="list-style-type: none"> Request for disabling the power stage 	
T11	6 -> 7	<ul style="list-style-type: none"> Error of error class 1 	Movement is canceled with "Quick Stop".
T12	7 -> 3	<ul style="list-style-type: none"> Request for disabling the power stage 	Power stage is disabled immediately, even if "Quick Stop" is still active.
T13	x -> 8	<ul style="list-style-type: none"> Error of error classes 2, 3 or 4 	Error response is carried out, see "Error Response".
T14	8 -> 9	<ul style="list-style-type: none"> Error response terminated (error class 2) Error of error classes 3 or 4 	
T15	9 -> 3	<ul style="list-style-type: none"> Function: "Fault Reset" 	Error is reset (cause of error must have been corrected).
T16	7 -> 6	<ul style="list-style-type: none"> Function: "Fault Reset" 	In the event of a "Quick Stop" triggered by a detected error of class 1, a "Fault Reset" causes a direct transition to the operating state 6 Operation Enabled.

(1) In order to trigger a state transition it is sufficient if one condition is met.

Parameter name	Description	Unit	Data type	Parameter address via fieldbus
HMI menu HMI name		Minimum value Factory setting Maximum value	R/W Persistent Expert	
<i>DSM_ShutDownOption</i> CONF → ACG - S d e y	Behavior for disabling the power stage during movement. 0 / Disable Immediately / d i s i : Disable power stage immediately 1 / Disable After Halt / d i s h : Disable power stage after deceleration to standstill This parameter specifies the response to a power stage disable request. Halt is used for deceleration to standstill. Modified settings become active immediately. Available with firmware version ≥V01.26.	- 0 0 1	INT16 R/W per. -	Modbus 1684

Indication of the Operating State via HMI

Description

The operating state is displayed by the HMI. The table below provides an overview:

Operating state	HMI
1 Start	<i>r n i t</i>
2 Not Ready To Switch On	<i>n r d y</i>
3 Switch On Disabled	<i>d i s</i>
4 Ready To Switch On	<i>r d y</i>
5 Switched On	<i>S o n</i>
6 Operation Enabled	<i>r u n</i>
7 Quick Stop Active	<i>S t o p</i>
8 Fault Reaction Active	<i>F L t</i>
9 Fault	<i>F L t</i>

Indication of the Operating State via Signal Outputs

Description

Information on the operating state is available via the signal outputs. The table below provides an overview:

Operating state	Signal output function "No fault" ⁽¹⁾	Signal output function "Active" ⁽²⁾
1 Start	0	0
2 Not Ready To Switch On	0	0
3 Switch On Disabled	0	0
4 Ready To Switch On	1	0
5 Switched On	1	0
6 Operation Enabled	1	1
7 Quick Stop Active	0	0
8 Fault Reaction Active	0	0
9 Fault	0	0

(1) The signal output function is factory setting for *DQ0*

(2) The signal output function is the factory setting for *DQ1*

Changing the Operating State via HMI

Description

An error message can be reset via the HMI.

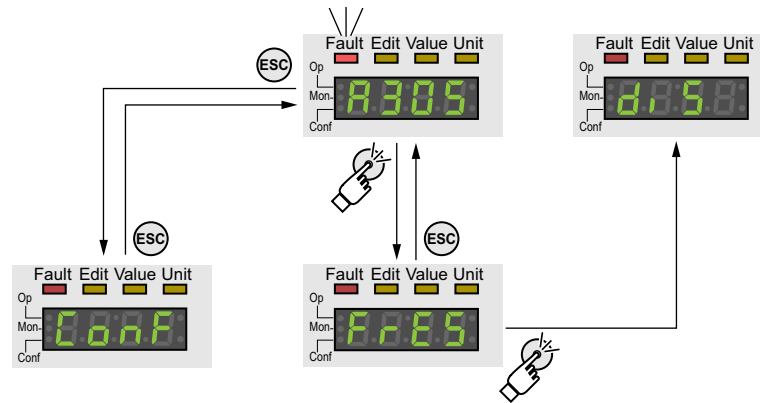

In the case of a detected error of error class 1, resetting the error message causes a transition from operating state 7 Quick Stop Active back to operating state 6 Operation Enabled.

In the case of a detected error of error classes 2 or 3, resetting the error message causes a transition from operating state 9 Fault back to operating state 3 Switch On Disabled.

Changing the Operating State via Signal Inputs

Overview

It is possible to switch between operating states via the signal inputs.

- Signal input function "Enable"
- Signal input function "Fault Reset"

Signal Input Function "Enable"

The power stage is enabled by means of the signal input function "Enable".

"Enable"	State transition
Rising edge	Enable power stage (T3)
Falling edge	Disabling the power stage (T9 and T12)

The signal input function "Enable" is the factory setting for *D10*.

As of firmware version $\geq V01.12$, it is possible to also reset an error message with a rising or a falling edge at the signal input.

Parameter name	Description	Unit	Data type	Parameter address via fieldbus
HMI menu		Minimum value	R/W	
HMI name		Factory setting	Persistent	
		Maximum value	Expert	
<i>IO_FaultResOnEnalnp</i>	Additional 'Fault Reset' for the signal input function 'Enable'.	-	UINT16	Modbus 1384
<i>CONF → RCG -</i>	0 / Off / o F F : No additional 'Fault Reset'	0	R/W	
<i>REFr</i>	1 / OnFallingEdge / F A L L : Additional 'Fault Reset' with falling edge	0	per.	
	2 / OnRisingEdge / r i S E : Additional 'Fault Reset' with rising edge	2	-	
	Modified settings become active the next time the power stage is enabled.			
	Available with firmware version $\geq V01.12$.			

Signal Input Function "Fault Reset"

The signal input function "Fault Reset" is used to reset an error message.

"Fault Reset"	State transition
Rising edge	Resetting an error message (T15 and T16)

The signal input function "Fault Reset" is the factory setting for *DI1*.

Operating Modes

Starting and Changing an Operating Mode

Starting the Operating Mode

The parameter *IOdefaultMode* is used to set the desired operating mode.

The set operating mode is automatically started by enabling the power stage.

Parameter name	Description	Unit	Data type	Parameter address via fieldbus
HMI menu		Minimum value	R/W	
HMI name		Factory setting	Persistent	
		Maximum value	Expert	
<i>IOdefaultMode</i>	Operating mode.	-	UINT16	Modbus 1286
<i>CONF → ACC -</i>	0 / None / NONE : None	0	R/W	
<i>io - Π</i>	1 / Profile Torque / Тор 9 : Profile Torque	5	per.	
	2 / Profile Velocity / ВЕЛ P : Profile Velocity	5	-	
	3 / Electronic Gear / ГЕАР : Electronic Gear			
	5 / Jog / JOG : Jog			
	Setting can only be modified if power stage is disabled.			
	Modified settings become active the next time the product is powered on.			

Starting the Operating Mode via Signal Input

As of firmware version $\geq V01.08$, the signal input function "Activate Operating Mode" is available.

This means that you can start the set operating mode via a signal input.

If the signal input function "Activate Operating Mode" has been set, the operating mode is not started automatically when the power stage is enabled. The operating mode is only started when a rising edge is available at the edge.

In order to start the set operating mode via a signal input, you must first parameterize the signal input function "Activate Operating Mode", see Digital Signal Inputs and Digital Signal Outputs, page 169.

Changing the Operating Mode

The operating mode can be changed after the active operating mode has been terminated.

In addition, it is also possible to change the operating mode during a running movement; however, this is only possible in certain operating modes.

Changing the Operating Mode During a Movement

You can switch between the following operating modes during a running movement.

- Electronic Gear
- Profile Torque
- Profile Velocity

The operating mode can be changed while the motor is at a standstill or while the motor is not at a standstill, depending on the new operating mode.

Operating mode to be changed to	Motor standstill
Jog	With motor standstill
Electronic Gear (position synchronization)	With motor standstill
Electronic Gear (velocity synchronization)	Without motor standstill
Profile Torque	Without motor standstill
Profile Velocity	Without motor standstill

The motor is decelerated to a standstill via the ramp set in the parameter *LIM_HaltReaction*, see Stopping Movement with Halt, page 237.

Changing the Operating Mode via Signal Input

The drive features the signal input function "Operating Mode Switch".

It allows you to switch via a signal input from the operating mode set in the *IOdefaultMode* to the operating mode set in the parameter *IO_ModeSwitch*.

In order to switch between two operating modes, you must first parameterize the signal input function "Operating Mode Switch", see Digital Signal Inputs and Digital Signal Outputs, page 169.

Parameter name HMI menu HMI name	Description	Unit Minimum value Factory setting Maximum value	Data type R/W Persistent Expert	Parameter address via fieldbus
<i>IO_ModeSwitch</i> CONF → RCL - IOS	Operating mode for signal input function Operating Mode Switch. 0 / None / none : None 1 / Profile Torque / Torq : Profile Torque 2 / Profile Velocity / VELP : Profile Velocity 3 / Electronic Gear / GER : Electronic Gear Modified settings become active immediately.	- 0 0 3	UINT16 R/W per. -	Modbus 1630

Operating Mode Jog

Overview

Description

In the operating mode Jog, a movement is made from the actual motor position in the specified direction.

A movement can be made using one of two methods:

- Continuous movement
- Step movement

In addition, the product features two parameterizable velocities.

Continuous Movement

As long as the signal for the direction is available, a continuous movement is made in the desired direction.

The illustration below provides an example of continuous movement:

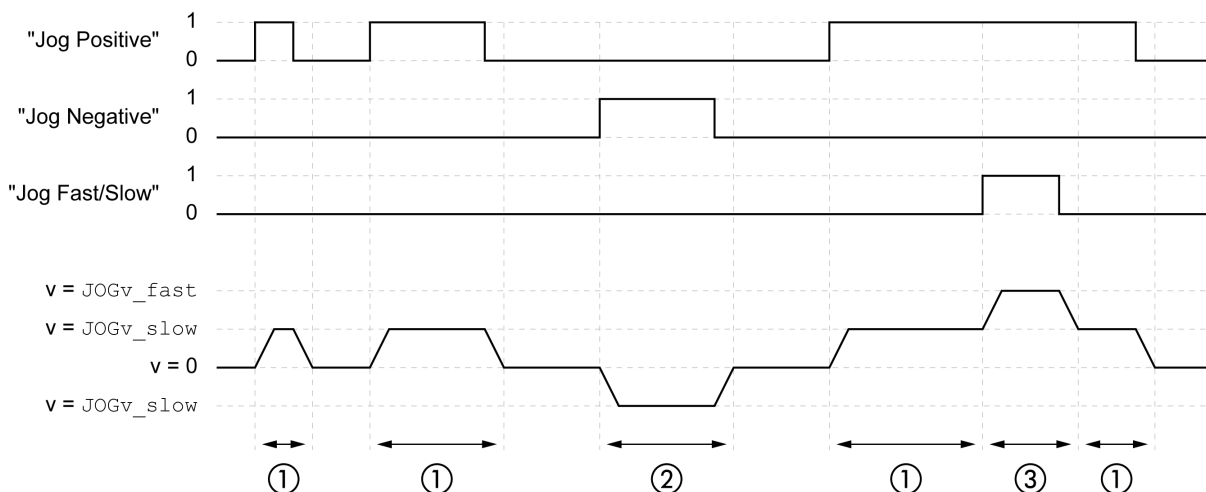

- 1 Slow movement in positive direction
- 2 Slow movement in negative direction
- 3 Fast movement in positive direction

Step Movement

If the signal for the direction is available for a short period of time, a movement with a parameterizable number of user-defined units is made in the desired direction.

If the signal for the direction is available continuously, a movement with a parameterizable number of user-defined units is made in the desired direction. After this movement, the motor stops for a defined period of time. Then a continuous movement is made in the desired direction.

The illustration provides an example of step movement:

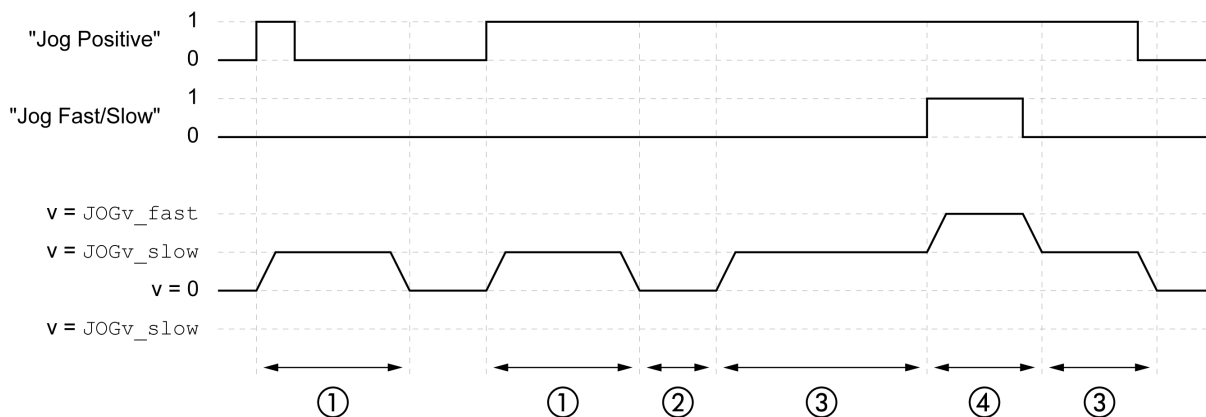

- 1 Slow movement in positive direction with a parameterizable number of user-defined units *JOGstep*
- 2 Waiting time *JOGtime*
- 3 Slow continuous movement in positive direction
- 4 Fast continuous movement in positive direction

Starting the Operating Mode

The operating mode must first have been selected, see *Starting and Changing an Operating Mode*, page 208. After the power stage is enabled, the operating mode is started automatically.

The power stage is enabled via the signal inputs. The table below provides an overview of the factory settings of the signal inputs:

Signal input	Signal input function
D10	"Enable" Enable and disable the power stage
D11	"Fault Reset" Resetting an error message
D12	"Positive Limit Switch (LIMP)" See Limit Switches, page 252
D13	"Negative Limit Switch (LIMN)" See Limit Switches, page 252
D14	"Jog Negative" Operating mode Jog: Movement in negative direction
D15	"Jog Positive" Operating mode Jog: Movement in positive direction

The factory settings of the signal inputs depend on the selected operating mode; they can be adapted, see *Digital Signal Inputs and Digital Signal Outputs*, page 169.

Integrated HMI

It is also possible to start the operating mode via the HMI. Calling $\rightarrow \text{P} \rightarrow \text{JOG} \rightarrow \text{JOGSE}$ enables the power stage and starts the operating mode.

The method Continuous Movement is controlled via the HMI.

Turn the navigation button to select one of 4 types of movement:

- $JG -$: slow movement in positive direction
- $JG =$: fast movement in positive direction
- $- JG$: slow movement in negative direction
- $= JG$: fast movement in negative direction

Press the navigation button to start the movement.

Status Messages

Information on the operating state and the ongoing movement is available via signal outputs.

The table below provides an overview of the signal outputs:

Signal output	Signal output function
DQ0	"No Fault" Signals the operating states 4 Ready To Switch On, 5 Switched On and 6 Operation Enabled
DQ1	"Active" Signals the operating state 6 Operation Enabled
DQ2	"In Position Deviation Window" See Position Deviation Window, page 257
DQ3	"Motor Standstill" See Motor Standstill and Direction of Movement, page 256
DQ4	"Selected Error" See Diagnostics via Signal Outputs, page 275

The factory settings of the signal outputs depend on the selected operating mode; they can be adapted, see Digital Signal Inputs and Digital Signal Outputs, page 169.

Terminating the Operating Mode

The operating mode is terminated when the motor is at a standstill and one of the following conditions is met:

- Stop caused by "Halt" or "Quick Stop"
- Stop caused by a detected error

Parameterization

Overview

The illustration below provides an overview of the adjustable parameters.

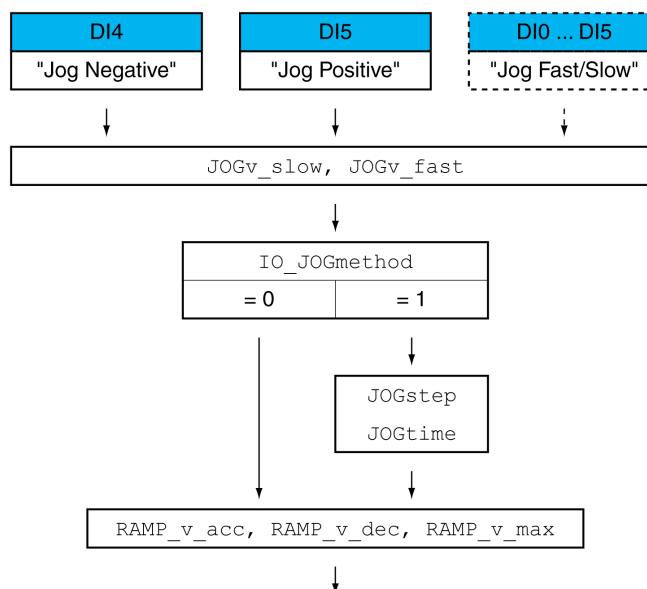

Velocities

Two parameterizable velocities are available.

Set the desired values with the parameters *JOGv_slow* and *JOGv_fast*.

Parameter name	Description	Unit	Data type	Parameter address via fieldbus
HMI menu		Minimum value	R/W	
HMI name		Factory setting	Persistent	
		Maximum value	Expert	
<i>JOGv_slow</i> P → J o G - J G L o	Velocity for slow movement. The adjustable value is internally limited to the parameter setting in <i>RAMP_v_max</i> . Modified settings become active immediately.	usr_v 1 60 2147483647	UINT32 R/W per. -	Modbus 10504
<i>JOGv_fast</i> P → J o G - J G h ,	Velocity for fast movement. The adjustable value is internally limited to the parameter setting in <i>RAMP_v_max</i> . Modified settings become active immediately.	usr_v 1 180 2147483647	UINT32 R/W per. -	Modbus 10506

Switching Between Velocities

The drive features the signal input function "Jog Fast/Slow". It allows you to switch between the two velocities via a signal input.

In order to switch between the two velocities, you must first parameterize the signal input function "Jog Fast/Slow", see Digital Signal Inputs and Digital Signal Outputs, page 169.

Selection of the Method

The parameter *IO_JOGmethod* lets you set the method.

Parameter name	Description	Unit	Data type	Parameter address via fieldbus
HMI menu		Minimum value	R/W	
HMI name		Factory setting	Persistent	
		Maximum value	Expert	
<i>IO_JOGmethod</i>	Selection of jog method.	-	UINT16	Modbus 1328
<i>CONFG → HLG - JOG</i>	<p>0 / Continuous Movement / CONT: Jog with continuous movement</p> <p>1 / Step Movement / STEP: Jog with step movement</p> <p>Modified settings become active the next time the motor moves.</p>	0 0 1	R/W per. -	

Setting the Step Movement

The parameters *JOGstep* and *JOGtime* are used to set the parameterizable number of user-defined units and the time for which the motor is stopped.

Parameter name	Description	Unit	Data type	Parameter address via fieldbus
HMI menu		Minimum value	R/W	
HMI name		Factory setting	Persistent	
		Maximum value	Expert	
<i>JOGstep</i>	Distance for step movement.	usr_p	INT32	Modbus 10510
	Modified settings become active the next time the motor moves.	1 20 2147483647	R/W per. -	
<i>JOGtime</i>	Wait time for step movement.	ms	UINT16	Modbus 10512
	Modified settings become active the next time the motor moves.	1 500 32767	R/W per. -	

Changing the Motion Profile for the Velocity

It is possible to change the parameterization of the Motion Profile for the Velocity, page 234.

Additional Settings

Overview

The following functions can be used for target value processing:

- Jerk Limitation, page 235
- Stopping Movement with Halt, page 237
- Stopping Movement with Quick Stop, page 238
- Limitation of the Velocity via Signal Inputs, page 240
- Limitation of the Current via Signal Inputs, page 243
- Relative Movement After Capture (RMAC), page 246

The following functions can be used for monitoring the movement:

- Limit Switches, page 252
- Load-Dependent Position Deviation (Following Error), page 253
- Motor Standstill and Direction of Movement, page 256

- Position Deviation Window, page 257
- Velocity Deviation Window, page 258
- Velocity Threshold Value, page 260
- Current Threshold Value, page 261

Operating Mode Electronic Gear

Overview

Description

In the operating mode Electronic Gear, movements are carried out according to externally supplied reference value signals. A position reference value is calculated on the basis of these external reference values plus an adjustable gear ratio. The reference value signals can be A/B signals, P/D signals or CW/CCW signals.

A movement can be made using one of 3 methods:

- Position synchronization without compensation movement

In the case of position synchronization without compensation movement, the movement is made synchronously (position synchronicity) with the supplied reference value signals. Reference value signals supplied during an interruption caused by Halt or by a detected error of error class 1 are not taken into account.

- Position synchronization with compensation movement

In the case of position synchronization with compensation movement, the movement is made synchronously (position synchronicity) with the supplied reference value signals. Reference value signals supplied during an interruption caused by Halt or by a detected error of error class 1 are taken into account and compensated for.

- Velocity synchronization

In the case of velocity synchronization, the movement is made synchronously (velocity synchronicity) with the supplied reference value signals.

Internal Units

The position value for the movement depends on the internal units.

The internal units are 131072 increments per revolution.

Starting the Operating Mode

The operating mode must first have been selected, see [Starting and Changing an Operating Mode](#), page 208. After the power stage is enabled, the operating mode is started automatically.

The power stage is enabled via the signal inputs. The table below provides an overview of the factory settings of the signal inputs:

Signal input	Signal input function
<i>DI0</i>	"Enable" Enable and disable the power stage
<i>DI1</i>	"Fault Reset" Resetting an error message
<i>DI2</i>	"Positive Limit Switch (LIMP)" See Limit Switches, page 252
<i>DI3</i>	"Negative Limit Switch (LIMN)" See Limit Switches, page 252

Signal input	Signal input function
<i>DI4</i>	"Gear Ratio Switch" Switch between 2 parameterizable gear ratios
<i>DI5</i>	"Halt" See Stopping Movement with Halt, page 237

The factory settings of the signal inputs depend on the selected operating mode; they can be adapted, see Digital Signal Inputs and Digital Signal Outputs, page 169.

Status Messages

Information on the operating state and the ongoing movement is available via signal outputs.

The table below provides an overview of the signal outputs:

Signal output	Signal output function
<i>DQ0</i>	"No Fault" Signals the operating states 4 Ready To Switch On, 5 Switched On and 6 Operation Enabled
<i>DQ1</i>	"Active" Signals the operating state 6 Operation Enabled
<i>DQ2</i>	"In Position Deviation Window" See Position Deviation Window, page 257
<i>DQ3</i>	"Motor Standstill" See Motor Standstill and Direction of Movement, page 256
<i>DQ4</i>	"Selected Error" See Diagnostics via Signal Outputs, page 275

The factory settings of the signal outputs depend on the selected operating mode; they can be adapted, see Digital Signal Inputs and Digital Signal Outputs, page 169.

Terminating the Operating Mode

The operating mode is automatically terminated by disabling the power stage.

Parameterization

Overview

The illustration below provides an overview of the adjustable parameters.

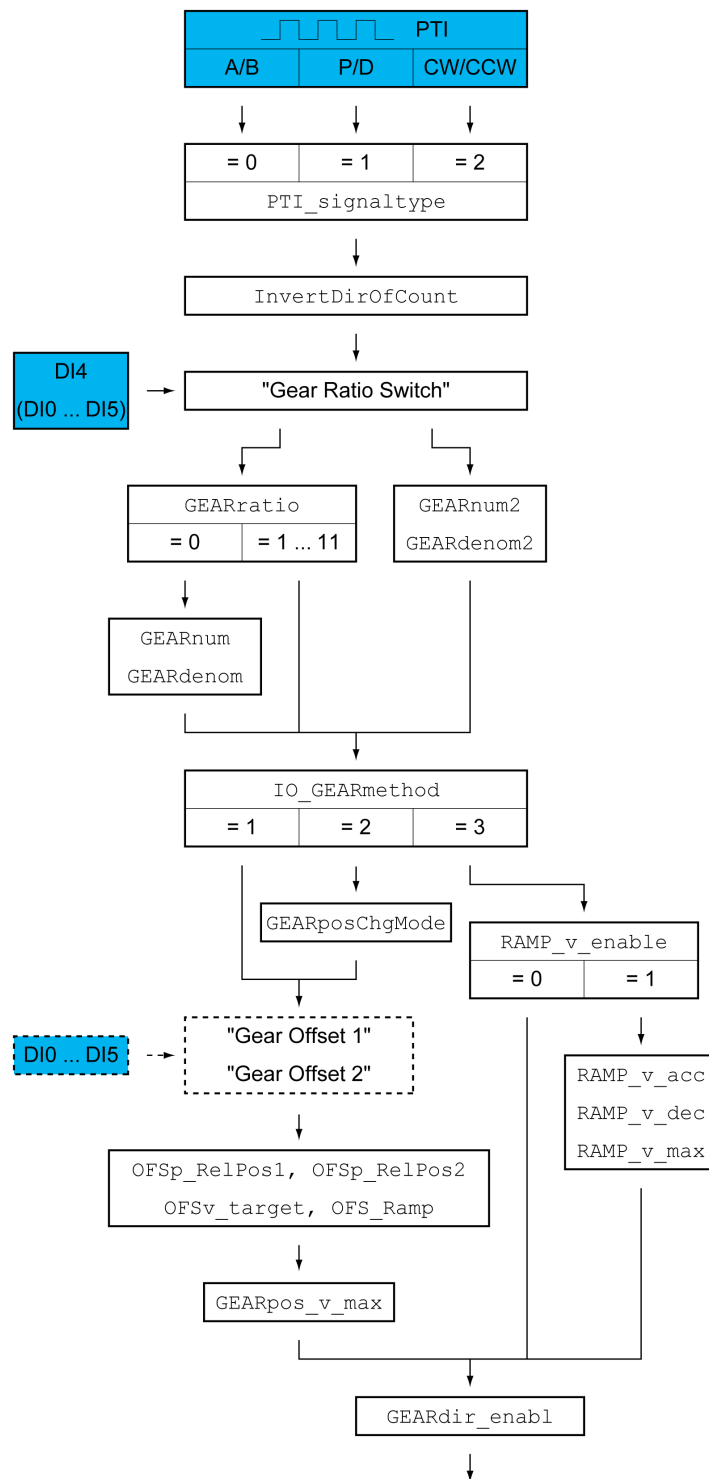

Type of Reference Value Signal and Inversion of the Reference Value Signals

The PTI interface can be set:

- Type of reference value signal
- Inverting the reference value signals

See section Setting the PTI Interface, page 184 for information on setting the PTI interface.

Gear Ratio

The gear ratio is the ratio of the number of motor increments and the number of externally supplied reference increments.

$$\text{Gear factor} = \frac{\text{Motor increments}}{\text{Reference increments}} = \frac{\text{Gear factor numerator}}{\text{Gear factor denominator}}$$

The signal input function "Gear Ratio Switch" allows you to switch between 2 parameterizable gear ratios during operation.

The parameter *GEARratio* allows you to set a predefined gear ratio. It is also possible to set a parameterizable gear ratio.

The parameterizable gear ratio is defined with the parameters *GEARnum* and *GEARdenom*. A negative numerator value reverses the motor's direction of movement.

Set the desired gear ratio with the parameters *GEARratio*, *GEARnum*, *GEARdenom*, *GEARnum2* and *GEARdenom2*.

Parameter name HMI menu HMI name	Description	Unit Minimum value Factory setting Maximum value	Data type R/W Persistent Expert	Parameter address via fieldbus
<i>GEARratio</i> CONF → 1 - 0 - G F R C	Selection of gear ratio. 0 / Gear Factor / F R C L : Usage of gear ratio adjusted with GEARnum/GEARdenom 1 / 200 / 200 : 200 2 / 400 / 400 : 400 3 / 500 / 500 : 500 4 / 1000 / 1000 : 1000 5 / 2000 / 2000 : 2000 6 / 4000 / 4000 : 4000 7 / 5000 / 5000 : 5000 8 / 10000 / 10000 : 10000 9 / 4096 / 4096 : 4096 10 / 8192 / 8192 : 8192 11 / 16384 / 16384 : 16384 A change of the reference value by the specified value causes one motor revolution. Modified settings become active immediately.	- 0 0 11	UINT16 R/W per. -	Modbus 9740
<i>GEARnum</i>	Numerator of gear ratio. GEARnum ----- = Gear ratio GEARdenom The new gear ratio is applied when the numerator value is supplied. Modified settings become active immediately.	- -2147483648 1 2147483647	INT32 R/W per. -	Modbus 9736
<i>GEARdenom</i>	Denominator of gear ratio. See description GEARnum	- 1 1 2147483647	INT32 R/W per. -	Modbus 9734

Parameter name	Description	Unit	Data type	Parameter address via fieldbus
HMI menu		Minimum value	R/W	
HMI name		Factory setting	Persistent	
		Maximum value	Expert	
<i>GEARnum2</i>	Numerator of gear ratio number 2. GEARnum2 ----- = Gear ratio GEARdenom2 The new gear ratio is applied when the numerator value is supplied. Modified settings become active immediately.	- -2147483648 1 2147483647	INT32 R/W per. -	Modbus 9754
<i>GEARdenom2</i>	Denominator of gear ratio number 2. See description GEARnum	- 1 1 2147483647	INT32 R/W per. -	Modbus 9752

Selection of the Method

The method specifies the way the movement is to be performed.

Set the desired method with the parameter *IO_GEARmethod*.

Parameter name	Description	Unit	Data type	Parameter address via fieldbus
HMI menu		Minimum value	R/W	
HMI name		Factory setting	Persistent	
		Maximum value	Expert	
<i>IO_GEARmethod</i> <i>C o n F → R C G -</i> <i>i o G n</i>	Processing mode for operating mode Electronic Gear. 1 / Position Synchronization Immediate / P o i n : Position synchronization without compensation movement 2 / Position Synchronization Compensated / P o c o : Position synchronization with compensation movement 3 / Velocity Synchronization / V E L o : Velocity synchronization Modified settings become active the next time the motor moves.	- 1 1 3	UINT16 R/W per. -	Modbus 1326

Position Change with Power Stage Disabled

If the method "Synchronization With Compensation Movement" is selected, the parameter *GEARposChgMode* determines the way changes to the motor position and to the reference value signals are handled with disabled power stage.

Position changes can be ignored or taken into account during a transition to operating state **6** Operation Enabled.

- Off: Position changes with disabled power stage are ignored.
- On: Position changes with disabled power stage are taken into account.

Position changes between starting the operating mode and the subsequent enabling of the power stage are not taken into account.

Parameter name	Description	Unit	Data type	Parameter address via fieldbus
HMI menu		Minimum value	R/W	
HMI name		Factory setting	Persistent	
		Maximum value	Expert	
<i>GEARposChgMode</i>	<p>Treatment of position changes with inactive power stage.</p> <p>0 / Off: Position changes in states with disabled power stage are ignored.</p> <p>1 / On: Position changes in states with disabled power stage are taken into account.</p> <p>This setting has an effect only if gear processing is started in the mode 'Synchronization with compensation movement'.</p> <p>Modified settings become active the next time the power stage is enabled.</p>	<p>-</p> <p>0</p> <p>0</p> <p>1</p>	<p>UINT16</p> <p>R/W</p> <p>per.</p> <p>-</p>	Modbus 9750

Offset Movement

The offset movement allows you to perform a movement with a parameterizable number of increments.

Offset movements are only available for the methods "Position Synchronization Without Compensation Movement" and "Position Synchronization With Compensation Movement".

Two parameterizable offset positions are available. The parameters *OFSp_RelPos1* and *OFSp_RelPos2* are used to set the offset positions.

An offset movement is started via a signal input.

In order to start offset movements via the signal input, you must first parameterize the signal input functions "Gear Offset 1" and "Gear Offset 2", see Digital Signal Inputs and Digital Signal Outputs, page 169.

The velocity and the acceleration for the offset movement are set via the parameters *OFSp_target* and *OFSp_Ramp*.

Parameter name	Description	Unit	Data type	Parameter address via fieldbus
HMI menu		Minimum value	R/W	
HMI name		Factory setting	Persistent	
		Maximum value	Expert	
<i>OFSp_RelPos1</i>	<p>Relative offset position 1 for offset movement.</p> <p>Modified settings become active immediately.</p>	<p>Inc</p> <p>-2147483648</p> <p>0</p> <p>2147483647</p>	<p>INT32</p> <p>R/W</p> <p>per.</p> <p>-</p>	Modbus 10000
<i>OFSp_RelPos2</i>	<p>Relative offset position 2 for offset movement.</p> <p>Modified settings become active immediately.</p>	<p>Inc</p> <p>-2147483648</p> <p>0</p> <p>2147483647</p>	<p>INT32</p> <p>R/W</p> <p>per.</p> <p>-</p>	Modbus 10004

Parameter name HMI menu HMI name	Description	Unit Minimum value Factory setting Maximum value	Data type R/W Persistent Expert	Parameter address via fieldbus
<i>OFSv_target</i>	<p>Target velocity for offset movement.</p> <p>The maximum value is 5000 if the user-defined scaling factor of the velocity scaling is 1.</p> <p>This applies to the user-defined scaling factors. Example: If the user-defined scaling factor of the velocity scaling is 2 (ScaleVELnum = 2, ScaleVELdenom = 1), the maximum value is 2500.</p> <p>Modified settings become active immediately.</p>	usr_v 1 60 2147483647	UINT32 R/W per. -	Modbus 9992
<i>OFS_Ramp</i>	<p>Acceleration and deceleration for offset movement.</p> <p>Setting can only be modified if power stage is disabled.</p> <p>Modified settings become active the next time the power stage is enabled.</p>	usr_a 1 600 2147483647	UINT32 R/W per. -	Modbus 9996

Changing the Motion Profile for the Velocity

If the method "Velocity Synchronization" is selected, the motion profile for the velocity can be changed.

It is possible to change the parameterization of the motion profile for the velocity, see [Motion Profile for the Velocity](#), page 234.

Velocity Limitation

As of firmware version $\geq V01.10$ a velocity limitation can be activated for the methods "Positions synchronization without compensation movement" and "Positions synchronisation with compensation movement".

Parameter name HMI menu HMI name	Description	Unit Minimum value Factory setting Maximum value	Data type R/W Persistent Expert	Parameter address via fieldbus
<i>GEARpos_v_max</i>	<p>Velocity limitation for the method Position Synchronization.</p> <p>Value 0: No velocity limitation</p> <p>Value >0: Velocity limitation in usr_v</p> <p>Modified settings become active immediately.</p> <p>Available with firmware version $\geq V01.10$.</p>	usr_v 0 0 2147483647	UINT32 R/W per. -	Modbus 9746

Release of Direction

Release of direction allows you to limit movements to positive or negative direction. Release of direction is set with the parameter *GEARdir_enabl*.

Parameter name	Description	Unit	Data type	Parameter address via fieldbus
HMI menu		Minimum value	R/W	
HMI name		Factory setting	Persistent	
		Maximum value	Expert	
<i>GEARdir_enabl</i>	<p>Enabled direction of movement for operating mode Electronic Gear.</p> <p>1 / Positive: Positive direction</p> <p>2 / Negative: Negative direction</p> <p>3 / Both: Both directions</p> <p>This allows you to activate a return movement lock function.</p> <p>Modified settings become active immediately.</p>	<p>-</p> <p>1</p> <p>3</p> <p>3</p>	<p>UINT16</p> <p>R/W</p> <p>per.</p> <p>-</p>	Modbus 9738

Additional Settings

Overview

The following functions can be used for target value processing:

- Jerk Limitation, page 235
This function is only available for the methods "Position Synchronization Without Compensation Movement" and "Position Synchronization With Compensation Movement".
- Stopping Movement with Halt, page 237
- Stopping Movement with Quick Stop, page 238
- Limitation of the Velocity via Signal Inputs, page 240
- Limitation of the Current via Signal Inputs, page 243
- Zero Clamp, page 246
This function is only available with the method "Velocity Synchronization".
- Relative Movement After Capture (RMAC), page 246

The following functions can be used for monitoring the movement:

- Limit Switches, page 252
- Load-Dependent Position Deviation (Following Error), page 253
This function is only available for the methods "Position Synchronization Without Compensation Movement" and "Position Synchronization With Compensation Movement".
- Motor Standstill and Direction of Movement, page 256
- Position Deviation Window, page 257
This function is only available for the methods "Position Synchronization Without Compensation Movement" and "Position Synchronization With Compensation Movement".
- Velocity Deviation Window, page 258
This function is only available with the method "Velocity Synchronization".
- Velocity Threshold Value, page 260
- Current Threshold Value, page 261

Operating Mode Profile Torque

Overview

Description

In the operating mode Profile Torque, a movement is made with a specified target torque.

The torque can be set via the following interface:

- Target torque via analog inputs
- Reference current via PTI interface (with firmware version $\geq V01.20$)

Without a proper limit value, the motor can reach an unintentionally high velocity in this operating mode.

▲ WARNING

UNINTENTIONALLY HIGH VELOCITY

Verify that the parameterized velocity limitation is appropriate for the motor.

Failure to follow these instructions can result in death, serious injury, or equipment damage.

Starting the Operating Mode

The operating mode must first have been selected, see [Starting and Changing an Operating Mode](#), page 208. After the power stage is enabled, the operating mode is started automatically.

The power stage is enabled via the signal inputs. The table below provides an overview of the factory settings of the signal inputs:

Signal input	Signal input function
<i>DI0</i>	"Enable" Enable and disable the power stage
<i>DI1</i>	"Fault Reset" Resetting an error message
<i>DI2</i>	"Operating Mode Switch" See Starting and Changing an Operating Mode , page 208
<i>DI3</i>	"Velocity Limitation" See Limitation of the Velocity via Signal Inputs , page 240
<i>DI4</i>	"Current Limitation" See Limitation of the Current via Signal Inputs , page 243
<i>DI5</i>	"Halt" See Stopping Movement with Halt , page 237

The factory settings of the signal inputs depend on the selected operating mode; they can be adapted, see [Digital Signal Inputs and Digital Signal Outputs](#), page 169.

Status Messages

Information on the operating state and the ongoing movement is available via signal outputs.

The table below provides an overview of the signal outputs:

Signal output	Signal output function
<i>DQ0</i>	"No Fault" Signals the operating states 4 Ready To Switch On, 5 Switched On and 6 Operation Enabled
<i>DQ1</i>	"Active" Signals the operating state 6 Operation Enabled
<i>DQ2</i>	"Current Below Threshold" See Current Threshold Value, page 261
<i>DQ3</i>	"Motor Standstill" See Motor Standstill and Direction of Movement, page 256
<i>DQ4</i>	"Selected Error" See Diagnostics via Signal Outputs, page 275

The factory settings of the signal outputs depend on the selected operating mode; they can be adapted, see Digital Signal Inputs and Digital Signal Outputs, page 169.

Terminating the Operating Mode

The operating mode is terminated when the motor is at a standstill and one of the following conditions is met:

- Stop caused by "Halt" or "Quick Stop"
- Stop caused by a detected error

Parameterization

Overview

The illustration below provides an overview of the adjustable parameters.

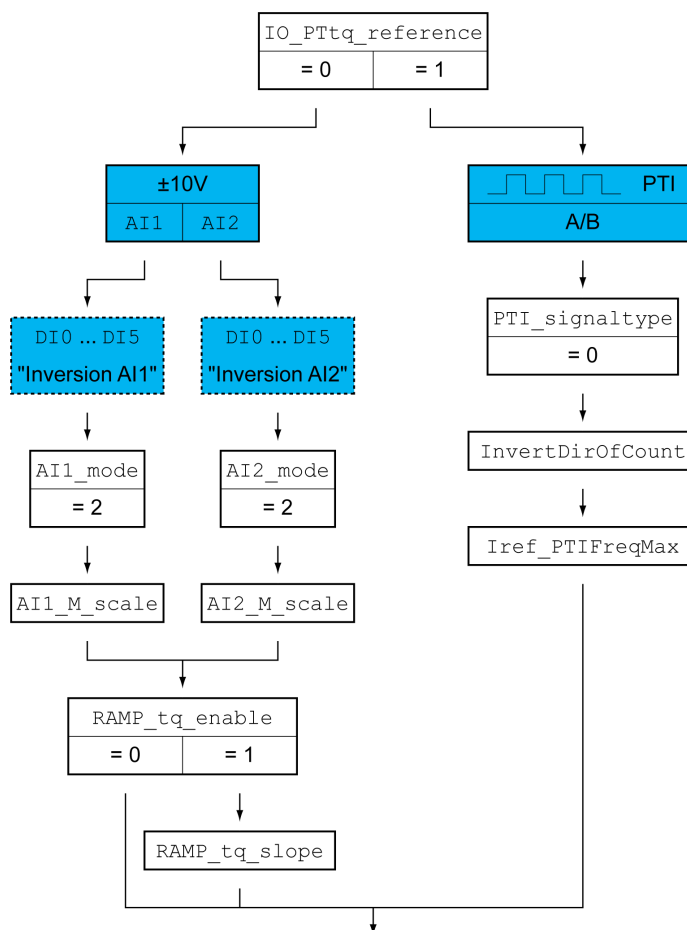

Setting the Source of the Reference Value

The parameter *IO_PTtq_reference* is used to set the source of the reference value.

Parameter name	Description	Unit	Data type	Parameter address via fieldbus
HMI menu		Minimum value	R/W	
HMI name		Factory setting	Persistent	
		Maximum value	Expert	
<i>IO_PTtq_reference</i> CONF → RLG - 10E9	Reference value source for operating mode Profile Torque. 0 / Analog Input / AI1/AI2 : Reference value via analog input 1 / PTI Interface / PTI : Reference value via PTI interface Setting can only be modified if power stage is disabled. Modified settings become active the next time the power stage is enabled. Available with firmware version ≥V01.20.	- 0 0 1	UINT16 R/W per. -	Modbus 1392

Offset and Zero Voltage Window (for Analog Inputs Only)

It is possible to change the development of the target value with reference to the ±10V input value:

- Parameterization of an offset

- Parameterization of a zero voltage window

See section *Inverting the Analog Signal Inputs*, page 240 for settings for the analog inputs.

Setting the Type of Usage (for Analog Inputs Only)

The parameters *AI1_mode* and *AI2_mode* let you select the type of usage of the analog signal inputs.

- If you want to use the analog signal input *AI1*, set the parameter *AI1_mode* to the value "Target Torque".
- If you want to use the analog signal input *AI2*, set the parameter *AI2_mode* to the value "Target Torque".

Parameter name HMI menu HMI name	Description	Unit Minimum value Factory setting Maximum value	Data type R/W Persistent Expert	Parameter address via fieldbus
<i>AI1_mode</i> CONF → I - 0 - R I 0 0	Analog 1: Type of usage. 0 / None / none : No function 1 / Target Velocity / SPd : Target velocity for the velocity controller 2 / Target Torque / Trq : Target torque for the current controller 3 / Velocity Limitation / LSPd : Limitation of the reference velocity for the velocity controller 4 / Current Limitation / Lcur : Limitation of the reference current for the current controller Setting can only be modified if power stage is disabled. Modified settings become active the next time the power stage is enabled.	- 0 1 4	UINT16 R/W per. -	Modbus 2332
<i>AI2_mode</i> CONF → I - 0 - R 2 0 0	Analog 2: Type of usage. 0 / None / none : No function 1 / Target Velocity / SPd : Target velocity for the velocity controller 2 / Target Torque / Trq : Target torque for the current controller 3 / Velocity Limitation / LSPd : Limitation of the reference velocity for the velocity controller 4 / Current Limitation / Lcur : Limitation of the reference current for the current controller 5 / Reserved / rsv : Reserved Setting can only be modified if power stage is disabled. Modified settings become active the next time the power stage is enabled.	- 0 0 5	UINT16 R/W per. -	Modbus 2342

Setting the Target Torque (for Analog Inputs Only)

The parameters *AI1_M_scale* and *AI2_M_scale* let you set the target torque for a voltage value of 10 V.

- If you want to use the analog signal input *AI1*, use the parameter *AI1_M_scale* to set the desired target torque for a voltage value of 10 V.
- If you want to use the analog signal input *AI2*, use the parameter *AI2_M_scale* to set the desired target torque for a voltage value of 10 V.

Parameter name HMI menu HMI name	Description	Unit Minimum value Factory setting Maximum value	Data type R/W Persistent Expert	Parameter address via fieldbus
<i>AI1_M_scale</i> <i>CONF → 1 - 0 -</i> <i>R1,5</i>	Analog 1: Target torque at 10 V in operating mode Profile Torque. 100.0 % correspond to the continuous stall torque <i>_M_M_0</i> . By using a negative sign, you can invert the evaluation of the analog signal. In increments of 0.1 %. Modified settings become active immediately.	% -3000.0 100.0 3000.0	INT16 R/W per. -	Modbus 2340
<i>AI2_M_scale</i> <i>CONF → 1 - 0 -</i> <i>R2,5</i>	Analog 2: Target torque at 10 V in operating mode Profile Torque. 100.0 % correspond to the continuous stall torque <i>_M_M_0</i> . By using a negative sign, you can invert the evaluation of the analog signal. In increments of 0.1 %. Modified settings become active immediately.	% -3000.0 100.0 3000.0	INT16 R/W per. -	Modbus 2350

Changing the Motion Profile for the Torque (for Analog Inputs Only)

It is possible to change the parameterization of the motion profile for the torque.

Parameter name HMI menu HMI name	Description	Unit Minimum value Factory setting Maximum value	Data type R/W Persistent Expert	Parameter address via fieldbus
<i>RAMP_tq_enable</i>	Activation of the motion profile for torque. 0 / Profile Off: Profile off 1 / Profile On: Profile on In the operating mode Profile Torque, the motion profile for torque can be activated or deactivated. In the other operating modes, the motion profile for torque is inactive. Setting can only be modified if power stage is disabled. Modified settings become active immediately.	- 0 0 1	UINT16 R/W per. -	Modbus 1624
<i>RAMP_tq_slope</i>	Slope setting of the motion profile for torque. 100.00 % of the torque setting correspond to the continuous stall torque <i>_M_M_0</i> . Example: A ramp setting of 10000.00 %/s results in a torque change of 100.0% of <i>_M_M_0</i> in 0.01s. In increments of 0.1 %/s. Modified settings become active immediately.	%/s 0.1 10000.0 3000000.0	UINT32 R/W per. -	Modbus 1620

Type of Reference Value Signal and Inversion of the Reference Value Signals (for PTI Interface Only)

The PTI interface can be set:

- Type of reference value signal (must be set to A/B signals)
- Inverting the reference value signals

See section Setting the PTI Interface, page 184 for information on setting the PTI interface.

Setting the Reference Current (for PTI Interface Only)

The parameter *Iref_PTIFreqMax* is used to set the reference current.

Parameter name HMI menu HMI name	Description	Unit Minimum value Factory setting Maximum value	Data type R/W Persistent Expert	Parameter address via fieldbus
<i>Iref_PTIFreqMax</i>	Reference current for operating mode Profile Torque via PTI interface. Reference current corresponding to 1.6 million increments per second at the PTI interface for operating mode Profile Torque. In increments of 0.01 A _{rms} . Modified settings become active immediately. Available with firmware version ≥V01.20.	A _{rms} 0.00 - 463.00	UINT16 R/W per. -	Modbus 8200

Additional Settings

Overview

The following functions can be used for target value processing:

- Stopping Movement with Halt, page 237
- Stopping Movement with Quick Stop, page 238
- Inverting the Analog Signal Inputs, page 240
- Limitation of the Velocity via Signal Inputs, page 240
- Limitation of the Current via Signal Inputs, page 243
- Relative Movement After Capture (RMAC), page 246

The following functions can be used for monitoring the movement:

- Limit Switches, page 252
- Motor Standstill and Direction of Movement, page 256
- Velocity Threshold Value, page 260
- Current Threshold Value, page 261

Operating Mode Profile Velocity

Overview

Description

In the operating mode Profile Velocity, a movement is made with a specified target velocity.

Starting the Operating Mode

The operating mode must first have been selected, see [Starting and Changing an Operating Mode](#), page 208. After the power stage is enabled, the operating mode is started automatically.

The power stage is enabled via the signal inputs. The table below provides an overview of the factory settings of the signal inputs:

Signal input	Signal input function
<i>DI0</i>	"Enable" Enable and disable the power stage
<i>DI1</i>	"Fault Reset" Resetting an error message
<i>DI2</i>	"Operating Mode Switch" See Starting and Changing an Operating Mode , page 208
<i>DI3</i>	"Velocity Limitation" See Limitation of the Velocity via Signal Inputs , page 240
<i>DI4</i>	"Zero Clamp" See Zero Clamp , page 246
<i>DI5</i>	"Halt" See Stopping Movement with Halt , page 237

The factory settings of the signal inputs depend on the selected operating mode; they can be adapted, see [Digital Signal Inputs and Digital Signal Outputs](#), page 169.

Status Messages

Information on the operating state and the ongoing movement is available via signal outputs.

The table below provides an overview of the signal outputs:

Signal output	Signal output function
<i>DQ0</i>	"No Fault" Signals the operating states 4 Ready To Switch On, 5 Switched On and 6 Operation Enabled
<i>DQ1</i>	"Active" Signals the operating state 6 Operation Enabled
<i>DQ2</i>	"In Velocity Deviation Window" See Velocity Deviation Window , page 258

Signal output	Signal output function
DQ3	"Motor Standstill" See Motor Standstill and Direction of Movement, page 256
DQ4	"Selected Error" See Diagnostics via Signal Outputs, page 275

The factory settings of the signal outputs depend on the selected operating mode; they can be adapted, see Digital Signal Inputs and Digital Signal Outputs, page 169.

Terminating the Operating Mode

The operating mode is terminated when the motor is at a standstill and one of the following conditions is met:

- Stop caused by "Halt" or "Quick Stop"
- Stop caused by a detected error

Parameterization

Overview

The illustration below provides an overview of the adjustable parameters.

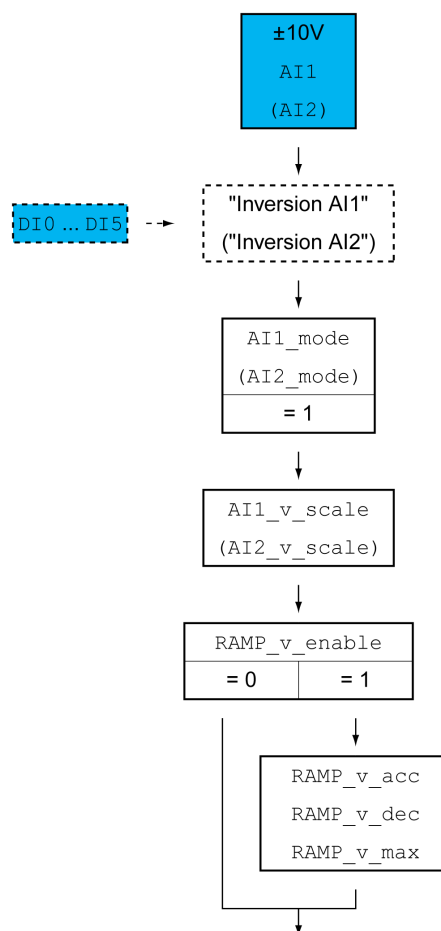

Offset and Zero Voltage Window

It is possible to change the development of the target value with reference to the $\pm 10V$ input value:

- Parameterization of an offset
- Parameterization of a zero voltage window

See section *Inverting the Analog Signal Inputs*, page 240 for settings for the analog inputs.

Setting the Type of Usage

The parameters *AI1_mode* and *AI2_mode* let you select the type of usage of the analog signal inputs.

- If you want to use the analog signal input *AI1*, set the parameter *AI1_mode* to the value "Target Velocity".
- If you want to use the analog signal input *AI2*, set the parameter *AI2_mode* to the value "Target Velocity".

Parameter name HMI menu HMI name	Description	Unit Minimum value Factory setting Maximum value	Data type R/W Persistent Expert	Parameter address via fieldbus
<i>AI1_mode</i> CONF → I - 0 - R I 0 0	Analog 1: Type of usage. 0 / None / none : No function 1 / Target Velocity / SPdS : Target velocity for the velocity controller 2 / Target Torque / TrqS : Target torque for the current controller 3 / Velocity Limitation / LSPd : Limitation of the reference velocity for the velocity controller 4 / Current Limitation / Lcur : Limitation of the reference current for the current controller Setting can only be modified if power stage is disabled. Modified settings become active the next time the power stage is enabled.	- 0 1 4	UINT16 R/W per. -	Modbus 2332
<i>AI2_mode</i> CONF → I - 0 - R 2 0 0	Analog 2: Type of usage. 0 / None / none : No function 1 / Target Velocity / SPdS : Target velocity for the velocity controller 2 / Target Torque / TrqS : Target torque for the current controller 3 / Velocity Limitation / LSPd : Limitation of the reference velocity for the velocity controller 4 / Current Limitation / Lcur : Limitation of the reference current for the current controller 5 / Reserved / rsvd : Reserved Setting can only be modified if power stage is disabled. Modified settings become active the next time the power stage is enabled.	- 0 0 5	UINT16 R/W per. -	Modbus 2342

Setting the Target Velocity

The parameters *A11_v_scale* and *A12_v_scale* are used to set the target velocity for a voltage value of 10 V.

- If you want to use the analog signal input *A11*, use the parameter *A11_v_scale* to set the desired target velocity for a voltage value of 10 V.
- If you want to use the analog signal input *A12*, use the parameter *A12_v_scale* to set the desired target velocity for a voltage value of 10 V.

Parameter name HMI menu HMI name	Description	Unit Minimum value Factory setting Maximum value	Data type R/W Persistent Expert	Parameter address via fieldbus
<i>A11_v_scale</i>	Analog 1: Target velocity at 10 V in operating mode Profile Velocity. The maximum velocity is limited to the setting in <i>CTRL_v_max</i> . By using a negative sign, you can invert the evaluation of the analog signal. Modified settings become active immediately.	usr_v -2147483648 6000 2147483647	INT32 R/W per. -	Modbus 2338
<i>A12_v_scale</i>	Analog 2: Target velocity at 10 V in operating mode Profile Velocity. The maximum velocity is limited to the setting in <i>CTRL_v_max</i> . By using a negative sign, you can invert the evaluation of the analog signal. Modified settings become active immediately.	usr_v -2147483648 6000 2147483647	INT32 R/W per. -	Modbus 2348

Changing the Motion Profile for the Velocity

It is possible to change the parameterization of the Motion Profile for the Velocity, page 234.

Additional Settings

Overview

The following functions can be used for target value processing:

- Stopping Movement with Halt, page 237
- Stopping Movement with Quick Stop, page 238
- Inverting the Analog Signal Inputs, page 240
- Limitation of the Velocity via Signal Inputs, page 240
- Limitation of the Current via Signal Inputs, page 243
- Zero Clamp, page 246
- Relative Movement After Capture (RMAC), page 246

The following functions can be used for monitoring the movement:

- Limit Switches, page 252
- Motor Standstill and Direction of Movement, page 256
- Velocity Deviation Window, page 258
- Velocity Threshold Value, page 260
- Current Threshold Value, page 261

Functions for Operation

Functions for Target Value Processing

Motion Profile for the Velocity

Description

Target position and target velocity are input values specified by the user. A motion profile for the velocity is calculated on the basis of these input values.

The motion profile for the velocity consists of an acceleration, a deceleration and a maximum velocity.

A linear ramp for both directions of movement is available.

Availability

The availability of the motion profile for the velocity depends on the operating mode.

In the following operating modes, the motion profile for the velocity is permanently active:

- Jog

In the following operating modes, the motion profile for the velocity can be activated and deactivated:

- Electronic Gear (velocity synchronization)
- Profile Velocity

In the following operating modes, the motion profile for the velocity is unavailable:

- Electronic Gear (position synchronization)
- Profile Torque

Ramp Slope

The ramp slope determines the velocity changes of the motor per time unit. The ramp slope can be set for acceleration and deceleration.

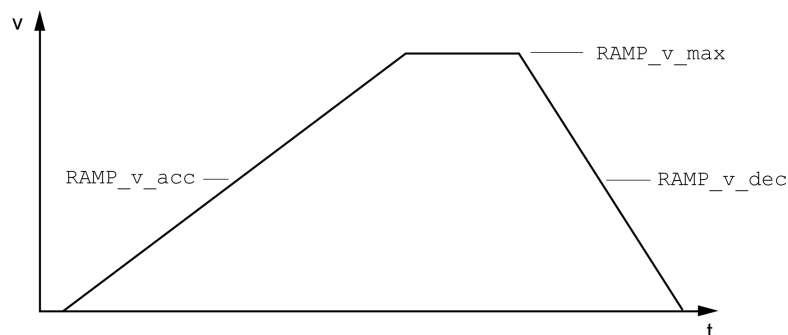

Parameter name HMI menu HMI name	Description	Unit Minimum value Factory setting Maximum value	Data type R/W Persistent Expert	Parameter address via fieldbus
<i>RAMP_v_enable</i>	<p>Activation of the motion profile for velocity.</p> <p>0 / Profile Off: Profile off</p> <p>1 / Profile On: Profile on</p> <p>Setting can only be modified if power stage is disabled.</p> <p>Modified settings become active immediately.</p>	- 0 0 1	UINT16 R/W per. -	Modbus 1622
<i>RAMP_v_max</i> C o n F → R L G - n r P P	<p>Maximum velocity of the motion profile for velocity.</p> <p>If a greater reference velocity is set in one of these operating modes, it is automatically limited to RAMP_v_max.</p> <p>This way, commissioning at limited velocity is easier to perform.</p> <p>Setting can only be modified if power stage is disabled.</p> <p>Modified settings become active the next time the motor moves.</p>	usr_v 1 13200 2147483647	UINT32 R/W per. -	Modbus 1554
<i>RAMP_v_acc</i>	<p>Acceleration of the motion profile for velocity.</p> <p>Writing the value 0 has no effect on the parameter.</p> <p>Modified settings become active the next time the motor moves.</p>	usr_a 1 600 2147483647	UINT32 R/W per. -	Modbus 1556
<i>RAMP_v_dec</i>	<p>Deceleration of the motion profile for velocity.</p> <p>The minimum value depends on the operating mode:</p> <p>Operating modes with minimum value 1: Electronic Gear (velocity synchronization) Profile Velocity</p> <p>Operating modes with minimum value 120: Jog</p> <p>Writing the value 0 has no effect on the parameter.</p> <p>Modified settings become active the next time the motor moves.</p>	usr_a 1 600 2147483647	UINT32 R/W per. -	Modbus 1558

Jerk Limitation

Description

Jerk limitation smoothes sudden acceleration changes to allow for smooth transitions with almost no jerking.

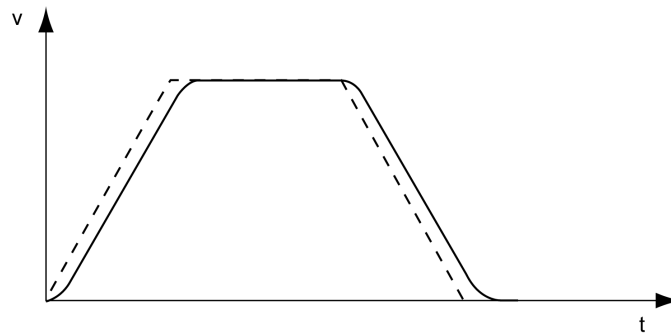

Availability

Jerk limitation is available in the following operating modes.

- Jog
- Electronic Gear (position synchronization)
(with firmware version $\geq V01.02$ and parameter *GEARjerklim*)

Settings

Jerk limitation is activated and set via the parameter *RAMP_v_jerk*.

Parameter name	Description	Unit	Data type	Parameter address via fieldbus
HMI menu		Minimum value	R/W	
HMI name		Factory setting	Persistent	
		Maximum value	Expert	
<i>RAMP_v_jerk</i>	Jerk limitation of the motion profile for velocity.	ms	UINT16	Modbus 1562
<i>CONF → drv → JEr</i>	<p>0 / Off / OFF: Off</p> <p>1 / 1 / 1: 1 ms</p> <p>2 / 2 / 2: 2 ms</p> <p>4 / 4 / 4: 4 ms</p> <p>8 / 8 / 8: 8 ms</p> <p>16 / 16 / 16: 16 ms</p> <p>32 / 32 / 32: 32 ms</p> <p>64 / 64 / 64: 64 ms</p> <p>128 / 128 / 128: 128 ms</p> <p>Adjustments can only be made if the operating mode is inactive ($x_{end}=1$).</p> <p>Modified settings become active the next time the motor moves.</p>	<p>0</p> <p>0</p> <p>128</p>	<p>R/W</p> <p>per.</p> <p>-</p>	

Operating Mode Electronic Gear

Jerk limitation is activated for the operating mode Electronic Gear (position synchronization) by means of the parameter *GEARjerklim*.

Parameter name HMI menu HMI name	Description	Unit Minimum value Factory setting Maximum value	Data type R/W Persistent Expert	Parameter address via fieldbus
<i>GEAR</i> <i>jerklim</i> <i>CONF</i> → <i>---</i> <i>GFIL</i>	<p>Activation of jerk limitation.</p> <p>0 / Off / OFF: Jerk limitation deactivated.</p> <p>1 / PosSyncOn / P_on: Jerk limitation active (only with position synchronization).</p> <p>The time for jerk limitation must be set via parameter RAMP_v_jerk.</p> <p>Setting can only be modified if power stage is disabled.</p> <p>Modified settings become active immediately.</p> <p>Available with firmware version ≥V01.02.</p>	- 0 0 1	UINT16 R/W per. -	Modbus 9742

Stopping Movement with Halt

Description

With a Halt, the ongoing movement is interrupted. The movement can be resumed when the Halt is cleared.

A Halt can be triggered via a digital signal input or a fieldbus command.

In order to interrupt a movement via a signal input, you must first parameterize the signal input function “Halt”, see Digital Signal Inputs and Digital Signal Outputs, page 169.

The following deceleration types are available:

- Deceleration via deceleration ramp
- Deceleration via torque ramp

Setting the Type of Deceleration

The parameter *LIM_HaltReaction* lets you set the type of deceleration.

Parameter name HMI menu HMI name	Description	Unit Minimum value Factory setting Maximum value	Data type R/W Persistent Expert	Parameter address via fieldbus
<i>LIM_HaltReaction</i> <i>CONF</i> → <i>ACG</i> - <i>HEYP</i>	<p>Halt option code.</p> <p>1 / Deceleration Ramp / DECE: Deceleration ramp</p> <p>3 / Torque Ramp / TORQ: Torque ramp</p> <p>Set the deceleration ramp with parameter RAMP_v_dec.</p> <p>Set the torque ramp with parameter LIM_I_maxHalt.</p> <p>If a deceleration ramp is already active, the parameter cannot be written.</p> <p>Modified settings become active immediately.</p>	- 1 1 3	INT16 R/W per. -	Modbus 1582

Setting the Deceleration Ramp

The deceleration ramp is set with the parameter *Ramp_v_dec* via the Motion Profile for the Velocity, page 234.

Setting the Torque Ramp

The parameter *LIM_I_maxHalt* lets you set the torque ramp.

Parameter name	Description	Unit	Data type	Parameter address via fieldbus
HMI menu		Minimum value	R/W	
HMI name		Factory setting	Persistent	
		Maximum value	Expert	
<i>LIM_I_maxHalt</i>	Current for Halt.	A _{rms}	UINT16	Modbus 4380
<i>CONF → AC G - hcur</i>	<p>This value is only limited by the minimum/maximum value range (no limitation of this value by motor/power stage).</p> <p>In the case of a Halt, the current limit (<i>_I_max_act</i>) is one of the following values (whichever is lowest):</p> <ul style="list-style-type: none"> - <i>LIM_I_maxHalt</i> - <i>_M_I_max</i> - <i>_PS_I_max</i> <p>Further current limitations caused by I2t monitoring are also taken into account during a Halt.</p> <p>Default: <i>_PS_I_max</i> at 8 kHz PWM frequency and 230/480 V mains voltage</p> <p>In increments of 0.01 A_{rms}.</p> <p>Modified settings become active immediately.</p>	- - -	R/W per. -	

Stopping Movement with Quick Stop

Description

With a Quick Stop, the ongoing movement is stopped.

A Quick Stop can be triggered by a detected error of error classes 1 or 2 or via a fieldbus command.

The movement can be stopped with 2 different deceleration types.

- Deceleration via deceleration ramp
- Deceleration via torque ramp

In addition, you can set the operating state to switch to after the deceleration.

- Transition to operating state **9** Fault
- Transition to operating state **7** Quick Stop Active

Setting the Type of Deceleration

The parameter *LIM_QStopReact* lets you set the type of deceleration.

Parameter name	Description	Unit	Data type	Parameter address via fieldbus
HMI menu		Minimum value	R/W	
HMI name		Factory setting	Persistent	
		Maximum value	Expert	
<i>LIM_QStopReact</i>	Quick Stop option code.	-	INT16	Modbus 1584
<i>Conf → FLT - 9EYP</i>	<p>6 / Deceleration ramp (Quick Stop) / Dec: Use deceleration ramp and remain in operating state 7 Quick Stop</p> <p>7 / Torque ramp (Quick Stop) / Tor: Use torque ramp and remain in operating state 7 Quick Stop</p> <p>Type of deceleration for Quick Stop.</p> <p>Setting of deceleration ramp with parameter RAMPquickstop.</p> <p>Setting of torque ramp with parameter LIM_I_maxQSTP.</p> <p>If a deceleration ramp is already active, the parameter cannot be written.</p> <p>Modified settings become active immediately.</p>	6 6 7	R/W per. -	

Setting the Deceleration Ramp

The parameter *RAMPquickstop* lets you set the deceleration ramp.

Parameter name	Description	Unit	Data type	Parameter address via fieldbus
HMI menu		Minimum value	R/W	
HMI name		Factory setting	Persistent	
		Maximum value	Expert	
<i>RAMPquickstop</i>	Deceleration ramp for Quick Stop.	usr_a	UINT32	Modbus 1572
	Deceleration ramp for a software stop or an error with error class 1 or 2.	1	R/W	
	Modified settings become active the next time the motor moves.	6000 2147483647	per. -	

Setting the Torque Ramp

The parameter *LIM_I_maxQSTP* lets you set the torque ramp.

Parameter name	Description	Unit	Data type	Parameter address via fieldbus
HMI menu		Minimum value	R/W	
HMI name		Factory setting	Persistent	
		Maximum value	Expert	
<i>LIM_I_maxQSTP</i>	Current for Quick Stop.	A_{rms}	UINT16	Modbus 4378
<i>CONF → FLT - Qcur</i>	<p>This value is only limited by the minimum/maximum value range (no limitation of this value by motor/power stage).</p> <p>In the case of a Quick Stop, the current limit (I_{max_act}) is one of the following values (whichever is lowest):</p> <ul style="list-style-type: none"> - <i>LIM_I_maxQSTP</i> - <i>M_I_max</i> - <i>PS_I_max</i> <p>Further current limitations caused by I2t monitoring are also taken into account during a Quick Stop.</p> <p>Default: <i>PS_I_max</i> at 8 kHz PWM frequency and 230/480 V mains voltage</p> <p>In increments of 0.01 A_{rms}.</p> <p>Modified settings become active immediately.</p>	- - -	R/W per. -	

Inverting the Analog Signal Inputs

Description

The evaluation of the analog signal inputs can be inverted via the digital signal inputs.

- The signal input function "Inversion AI1" inverts the signal evaluation of the analog signal input AI1.
- The signal input function "Inversion AI2" inverts the signal evaluation of the analog signal input AI2.

In order to invert the signal evaluation of the analog signal inputs, you must first parameterize the signal input functions "Inversion AI1" and/or "Inversion AI2", see Digital Signal Inputs and Digital Signal Outputs, page 169.

Availability

The signal input functions are available in the following operating modes:

- Profile Torque
- Profile Velocity

Limitation of the Velocity via Signal Inputs

Limitation via Analog Signal Input

The velocity can be limited via an analog signal input.

The parameters *A1_mode* and *A2_mode* let you select the type of usage of the analog signal inputs.

- If you want to use the analog signal input *A1*, set the parameter *A1_mode* to the value "Velocity Limitation".
- If you want to use the analog signal input *A2*, set the parameter *A2_mode* to the value "Velocity Limitation".

Parameter name HMI menu HMI name	Description	Unit Minimum value Factory setting Maximum value	Data type R/W Persistent Expert	Parameter address via fieldbus
<i>A1_mode</i> CONF → I - 0 - R1P0	Analog 1: Type of usage. 0 / None / none : No function 1 / Target Velocity / SPdS : Target velocity for the velocity controller 2 / Target Torque / TrqS : Target torque for the current controller 3 / Velocity Limitation / LSPd : Limitation of the reference velocity for the velocity controller 4 / Current Limitation / Lcur : Limitation of the reference current for the current controller Setting can only be modified if power stage is disabled. Modified settings become active the next time the power stage is enabled.	- 0 1 4	UINT16 R/W per. -	Modbus 2332
<i>A2_mode</i> CONF → I - 0 - R2P0	Analog 2: Type of usage. 0 / None / none : No function 1 / Target Velocity / SPdS : Target velocity for the velocity controller 2 / Target Torque / TrqS : Target torque for the current controller 3 / Velocity Limitation / LSPd : Limitation of the reference velocity for the velocity controller 4 / Current Limitation / Lcur : Limitation of the reference current for the current controller 5 / Reserved / rsvd : Reserved Setting can only be modified if power stage is disabled. Modified settings become active the next time the power stage is enabled.	- 0 0 5	UINT16 R/W per. -	Modbus 2342

The parameters *A1_v_max* and *A2_v_max* are used to set the value of the limitation for a voltage value of 10 V.

- If you want to use the analog signal input *A1*, use the parameter *A1_v_max* to set the value of the limitation for a voltage value of 10 V.
- If you want to use the analog signal input *A2*, use the parameter *A2_v_max* to set the value of the limitation for a voltage value of 10 V.

Parameter name HMI menu HMI name	Description	Unit Minimum value Factory setting Maximum value	Data type R/W Persistent Expert	Parameter address via fieldbus
<i>A11_v_max</i>	Analog 1: Limitation of velocity at 10 V. The maximum velocity is limited to the setting in CTRL_v_max. The minimum velocity is internally limited to 100 RPM. Setting can only be modified if power stage is disabled. Modified settings become active the next time the power stage is enabled.	usr_v 1 3000 2147483647	UINT32 R/W per. -	Modbus 2336
<i>A12_v_max</i>	Analog 2: Limitation of velocity at 10 V. The maximum velocity is limited to the setting in CTRL_v_max. The minimum velocity is internally limited to 100 RPM. Setting can only be modified if power stage is disabled. Modified settings become active the next time the power stage is enabled.	usr_v 1 3000 2147483647	UINT32 R/W per. -	Modbus 2346

Limitation via Digital Signal Input

The velocity can be limited to a specific value via a digital signal input.

The parameter *IO_v_limit* lets you set the velocity limitation.

Parameter name HMI menu HMI name	Description	Unit Minimum value Factory setting Maximum value	Data type R/W Persistent Expert	Parameter address via fieldbus
<i>IO_v_limit</i>	Velocity limitation via input. A velocity limitation can be activated via a digital input. In operating mode Profile Torque, the minimum velocity is internally limited to 100 RPM. Modified settings become active immediately.	usr_v 0 10 2147483647	UINT32 R/W per. -	Modbus 1596

In order to limit the velocity via a digital signal input, you must first parameterize the signal input function "Velocity Limitation", see Digital Signal Inputs and Digital Signal Outputs, page 169.

As of firmware version $\geq V01.26$ you can configure the signal evaluation of the signal input function via the parameter *IOSigVelLim*.

Parameter name	Description	Unit	Data type	Parameter address via fieldbus
HMI menu		Minimum value	R/W	
HMI name		Factory setting	Persistent	
		Maximum value	Expert	
<i>IOsigVelLim</i>	<p>Signal evaluation for signal input function Velocity Limitation.</p> <p>1 / Normally Closed: Normally closed NC</p> <p>2 / Normally Open: Normally open NO</p> <p>Setting can only be modified if power stage is disabled.</p> <p>Modified settings become active the next time the power stage is enabled.</p> <p>Available with firmware version $\geq V01.26$.</p>	- 1 2 2	UINT16 R/W per. -	Modbus 2126

Limitation of the Current via Signal Inputs

Limitation via Analog Signal Input

The current can be limited via an analog signal input.

The parameters *A11_mode* and *A12_mode* let you select the type of usage of the analog signal inputs.

- If you want to use the analog signal input *A11*, set the parameter *A11_mode* to the value "Current Limitation".
- If you want to use the analog signal input *A12*, set the parameter *A12_mode* to the value "Current Limitation".

Parameter name	Description	Unit	Data type	Parameter address via fieldbus
HMI menu		Minimum value	R/W	
HMI name		Factory setting	Persistent	
		Maximum value	Expert	
<i>A11_mode</i> CONF → I - 0 - R I 0 0	<p>Analog 1: Type of usage.</p> <p>0 / None / none: No function</p> <p>1 / Target Velocity / SPd5: Target velocity for the velocity controller</p> <p>2 / Target Torque / Trq5: Target torque for the current controller</p> <p>3 / Velocity Limitation / LSPd: Limitation of the reference velocity for the velocity controller</p> <p>4 / Current Limitation / Lcur: Limitation of the reference current for the current controller</p> <p>Setting can only be modified if power stage is disabled.</p> <p>Modified settings become active the next time the power stage is enabled.</p>	- 0 1 4	UINT16 R/W per. -	Modbus 2332
<i>A12_mode</i> CONF → I - 0 - R 2 0 0	<p>Analog 2: Type of usage.</p> <p>0 / None / none: No function</p> <p>1 / Target Velocity / SPd5: Target velocity for the velocity controller</p> <p>2 / Target Torque / Trq5: Target torque for the current controller</p> <p>3 / Velocity Limitation / LSPd: Limitation of the reference velocity for the velocity controller</p> <p>4 / Current Limitation / Lcur: Limitation of the reference current for the current controller</p> <p>5 / Reserved / rsvd: Reserved</p> <p>Setting can only be modified if power stage is disabled.</p> <p>Modified settings become active the next time the power stage is enabled.</p>	- 0 0 5	UINT16 R/W per. -	Modbus 2342

The parameters *A11_l_max* and *A12_l_max* are used to set the value of the limitation for a voltage value of 10 V.

- If you want to use the analog signal input *A11*, use the parameter *A11_l_max* to set the value of the limitation for a voltage value of 10 V.
- If you want to use the analog signal input *A12*, use the parameter *A12_l_max* to set the value of the limitation for a voltage value of 10 V.

Parameter name	Description	Unit	Data type	Parameter address via fieldbus
HMI menu		Minimum value	R/W	
HMI name		Factory setting	Persistent	
		Maximum value	Expert	
<i>A1_I_max</i> CONF → I - 0 - R I , L	Analog 1: Limitation of current at 10 V. In increments of 0.01 A _{rms} . Setting can only be modified if power stage is disabled. Modified settings become active the next time the power stage is enabled.	A _{rms} 0.00 3.00 463.00	UINT16 R/W per. -	Modbus 2334
<i>A2_I_max</i> CONF → I - 0 - R 2 , L	Analog 2: Limitation of current at 10 V. In increments of 0.01 A _{rms} . Setting can only be modified if power stage is disabled. Modified settings become active the next time the power stage is enabled.	A _{rms} 0.00 3.00 463.00	UINT16 R/W per. -	Modbus 2344

Limitation via Digital Signal Input

The current can be limited to a specific value via a digital signal input.

The parameter *IO_I_limit* lets you set the current limitation.

Parameter name	Description	Unit	Data type	Parameter address via fieldbus
HMI menu		Minimum value	R/W	
HMI name		Factory setting	Persistent	
		Maximum value	Expert	
<i>IO_I_limit</i> CONF → I - 0 - I L , Π	Current limitation via input. A current limit can be activated via a digital input. In increments of 0.01 A _{rms} . Modified settings become active immediately.	A _{rms} 0.00 0.20 300.00	UINT16 R/W per. -	Modbus 1614

In order to limit the current via a digital signal input, you must first parameterize the signal input function “Current Limitation”, see Digital Signal Inputs and Digital Signal Outputs, page 169.

As of firmware version ≥V01.26 you can configure the signal evaluation of the signal input function via the parameter *IOsigCurrLim*.

Parameter name	Description	Unit	Data type	Parameter address via fieldbus
HMI menu		Minimum value	R/W	
HMI name		Factory setting	Persistent	
		Maximum value	Expert	
<i>IOsigCurrLim</i>	Signal evaluation for signal input function Current Limitation. 1 / Normally Closed: Normally closed NC 2 / Normally Open: Normally open NO Setting can only be modified if power stage is disabled. Modified settings become active the next time the power stage is enabled. Available with firmware version ≥V01.26.	- 1 2 2	UINT16 R/W per. -	Modbus 2128

Zero Clamp

Description

The motor can be stopped via a digital signal input. The velocity of the motor must be below a parameterizable velocity value.

Availability

The signal input function “Zero Clamp” is available in the following operating mode:

- Electronic Gear (velocity synchronization)
- Profile Velocity

Settings

Target velocities in the operating mode Profile Velocity and reference velocities in the operating mode Electronic Gear (Velocity Synchronization) that are below the parameterizable velocity value are interpreted as "Zero".

The signal input function “Zero Clamp” has a hysteresis of 20 %.

The parameter *MON_v_zeroclamp* lets you set the velocity value.

Parameter name	Description	Unit	Data type	Parameter address via fieldbus
HMI menu		Minimum value	R/W	
HMI name		Factory setting	Persistent	
		Maximum value	Expert	
<i>MON_v_zeroclamp</i>	Velocity limit for Zero Clamp. A Zero Clamp operation is only possible if the reference velocity is below the Zero Clamp velocity limit. Modified settings become active immediately.	usr_v 0 10 2147483647	UINT32 R/W per. -	Modbus 1616

In order to stop the motor via a digital signal input, you must first parameterize the signal input function “Zero Clamp”, see Digital Signal Inputs and Digital Signal Outputs, page 169.

Relative Movement After Capture (RMAC)

Description

Relative Movement After Capture (RMAC) starts a relative movement via a signal input while another movement is running.

The target position and the velocity can be parameterized.

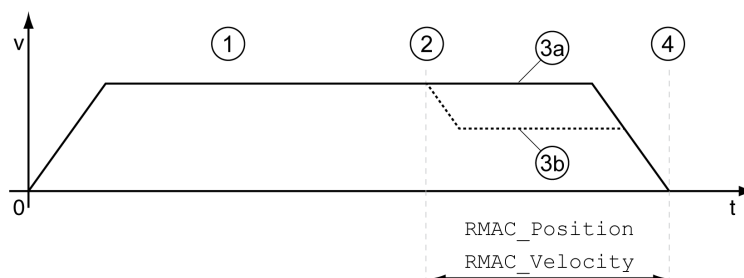

- 1** Movement with set operating mode (for example operating mode Profile Velocity)
- 2** Start of the relative movement after capture with the signal input function Start Signal Of RMAC
- 3a** Relative movement after capture is performed with unchanged velocity
- 3b** Relative movement after capture is performed with parameterized velocity
- 4** Target position reached

Availability

A Relative Movement After Capture (RMAC) can be started in the following operating modes:

- Jog
- Electronic Gear
- Profile Torque
- Profile Velocity

Available with hardware version ≥RS03.

Signal Input Functions

The following signal input functions are required to start the relative movement:

Signal input function	Meaning	Activation
Activate RMAC	Activation of relative movement after capture	1 level
Start Signal Of RMAC	Start signal for relative movement	Adjustable via parameter <i>RMAC_Edge</i>
Activate Operating Mode	When the relative movement has terminated, the operating mode is resumed.	Rising edge

The signal input functions must have been parameterized, see Digital Signal Inputs and Digital Signal Outputs, page 169.

Status Indication

The status is available via a signal output. In order to read the status, you must first parameterize the signal output function "RMAC Active Or Finished", see Digital Signal Inputs and Digital Signal Outputs, page 169.

Activates Relative Movement After Capture

Relative Movement After Capture (RMAC) must be activated before it can be started.

Relative Movement After Capture is activated via the signal input function "Activate RMAC".

Target Values

The target position and the velocity for the relative movement are set via the following parameters.

Parameter name HMI menu HMI name	Description	Unit Minimum value Factory setting Maximum value	Data type R/W Persistent Expert	Parameter address via fieldbus
<i>RMAC_Position</i>	Target position of relative movement after capture. Minimum/maximum values depend on: - Scaling factor Modified settings become active the next time the motor moves. Available with firmware version \geq V01.10.	usr_p - 0 -	INT32 R/W per. -	Modbus 8986
<i>RMAC_Velocity</i>	Velocity of relative movement after capture. Value 0: Use actual motor velocity Value >0: Value is the target velocity The adjustable value is internally limited to the setting in RAMP_v_max. Modified settings become active the next time the motor moves. Available with firmware version \geq V01.10.	usr_v 0 0 2147483647	UINT32 R/W per. -	Modbus 8988

Edge for the Start Signal

The edge which is to trigger the relative movement is set via the following parameter.

Parameter name HMI menu HMI name	Description	Unit Minimum value Factory setting Maximum value	Data type R/W Persistent Expert	Parameter address via fieldbus
<i>RMAC_Edge</i>	Edge of capture signal for relative movement after capture. 0 / Falling edge: Falling edge 1 / Rising edge: Rising edge Available with firmware version \geq V01.10.	- 0 0 1	UINT16 R/W per. -	Modbus 8992

Response to Overtravelling of the Target Position

Depending on the set velocity, target position and deceleration ramp, the target position may be overtraveled.

The response to overtravelling of the target position is set via the following parameter.

Parameter name	Description	Unit	Data type	Parameter address via fieldbus
HMI menu		Minimum value	R/W	
HMI name		Factory setting	Persistent	
		Maximum value	Expert	
<i>RMAC_Response</i>	Response if target position is overtraveled. 0 / Error Class 1: Error class 1 1 / No Movement To Target Position: No movement to target position 2 / Movement To Target Position: Movement to target position Modified settings become active immediately. Available with firmware version \geq V01.10.	- 0 0 2	UINT16 R/W per. -	Modbus 8990

Backlash Compensation

Description

By setting backlash compensation, you can compensate for mechanical backlash.

Example of mechanical backlash

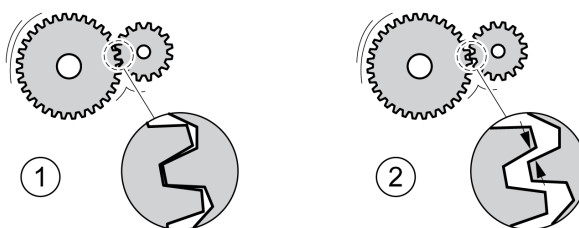

1 Example of low mechanical backlash

2 Example of high mechanical backlash

When backlash compensation is activated, the drive automatically compensates for the mechanical backlash during each movement.

Availability

Available with firmware version \geq V01.14.

Backlash compensation is possible in the following operating modes:

- Jog
- Electronic Gear (position synchronization)

Parameterization

To use backlash compensation, you must set the amount of backlash.

The parameter *BLSH_Position* lets you set the amount of backlash in user-defined units.

Parameter name	Description	Unit	Data type	Parameter address via fieldbus
HMI menu		Minimum value	R/W	
HMI name		Factory setting	Persistent	
		Maximum value	Expert	
<i>BLSH_Position</i>	Position value for backlash compensation. Setting can only be modified if power stage is disabled. Modified settings become active the next time the power stage is enabled. Available with firmware version \geq V01.14.	usr_p 0 0 2147483647	INT32 R/W per. -	Modbus 1668

In addition, you can set a processing time. The processing time specifies the period of time during which the mechanical backlash is to be compensated for.

The parameter *BLSH_Time* lets you set the processing time in ms.

Parameter name	Description	Unit	Data type	Parameter address via fieldbus
HMI menu		Minimum value	R/W	
HMI name		Factory setting	Persistent	
		Maximum value	Expert	
<i>BLSH_Time</i>	Processing time for backlash compensation. Value 0: Immediate backlash compensation Value >0: Processing time for backlash compensation Setting can only be modified if power stage is disabled. Modified settings become active the next time the power stage is enabled. Available with firmware version \geq V01.14.	ms 0 0 16383	UINT16 R/W per. -	Modbus 1672

Activating Backlash Compensation

Before you can activate backlash compensation, there must be a movement in positive or negative direction. Backlash compensation is activated with the parameter *BLSH_Mode*.

- Start a movement in positive direction or in negative direction. This movement must last as long as it takes to move the mechanical system connected to the motor.
- If the movement was in positive direction (positive target values), activate backlash compensation with the value "OnAfterPositiveMovement".
- If the movement was in negative direction (negative target values), activate backlash compensation with the value "OnAfterNegativeMovement".

Parameter name HMI menu HMI name	Description	Unit Minimum value Factory setting Maximum value	Data type R/W Persistent Expert	Parameter address via fieldbus
<i>BLSH_Mode</i>	<p>Processing mode of backlash compensation.</p> <p>0 / Off: Backlash compensation is off</p> <p>1 / OnAfterPositiveMovement: Backlash compensation is on, last movement was in positive direction</p> <p>2 / OnAfterNegativeMovement: Backlash compensation is on, last movement was in negative direction</p> <p>Modified settings become active immediately.</p> <p>Available with firmware version \geqV01.14.</p>	- 0 0 2	UINT16 R/W per. -	Modbus 1666

Functions for Monitoring Movements

Limit Switches

Description

The use of limit switches can help protect against some hazards (for example, collision with mechanical stop caused by incorrect reference values).

⚠ WARNING

LOSS OF CONTROL

- Ensure that limit switches are installed as determined by your risk assessment.
- Verify correct connection of the limit switches.
- Verify that the limit switches are sufficiently distant from the mechanical end to allow an adequate stopping distance.
- Verify correct parameterization and function of the limit switches.

Failure to follow these instructions can result in death, serious injury, or equipment damage.

Movements can be monitored using limit switches. A positive limit switch and a negative limit switch can be used for monitoring.

If the positive or negative limit switch are tripped, the movement stops. An error message is generated and the operating state switches to **7 Quick Stop Active**.

The error message can be reset by means of a "Fault Reset". The operating state switches back to **6 Operation Enabled**.

The movement can continue, however, only in the opposite direction. For example, if the positive limit switch was triggered, further movement is only possible in negative direction. In the case of further movement in positive direction, a new error message is generated and the operating state switches back to **7 Quick Stop Active**.

The parameters *IOsigLIMP* and *IOsigLIMN* are used to set the type of limit switch.

Parameter name	Description	Unit	Data type	Parameter address via fieldbus
HMI menu		Minimum value	R/W	
HMI name		Factory setting	Persistent	
		Maximum value	Expert	
<i>IOsigLIMP</i>	Signal evaluation for positive limit switch. 0 / Inactive: Inactive 1 / Normally Closed: Normally closed NC 2 / Normally Open: Normally open NO Setting can only be modified if power stage is disabled. Modified settings become active the next time the power stage is enabled.	- 0 1 2	UINT16 R/W per. -	Modbus 1568
<i>IOsigLIMN</i>	Signal evaluation for negative limit switch. 0 / Inactive: Inactive 1 / Normally Closed: Normally closed NC 2 / Normally Open: Normally open NO Setting can only be modified if power stage is disabled. Modified settings become active the next time the power stage is enabled.	- 0 1 2	UINT16 R/W per. -	Modbus 1568

The signal input functions “Positive Limit Switch (LIMP)” and “Negative Limit Switch (LIMN)” must have been parameterized, see Digital Signal Inputs and Digital Signal Outputs, page 169.

Load-Dependent Position Deviation (Following Error)

Description

The load-dependent position deviation is the difference between the reference position and the actual position caused by the load inertia.

Parameters are available to read the load-dependent position deviation during operation and the maximum position deviation reached since the last power cycle.

The maximum permissible load-dependent position deviation can be parameterized. In addition, you can set the error class.

Availability

Monitoring of the load-dependent position deviation is available in the following operating modes:

- Jog
- Electronic Gear (position synchronization)

Reading the Position Deviation

The following parameters let you read the load-dependent position deviation.

Parameter name HMI menu HMI name	Description	Unit Minimum value Factory setting Maximum value	Data type R/W Persistent Expert	Parameter address via fieldbus
<i>_p_dif_load_usr</i>	Load-dependent position deviation between reference and actual positions. The load-dependent position deviation is the difference between the reference position and the actual position caused by the load. This value is used for following error monitoring. Available with firmware version $\geq V01.05$.	usr_p -2147483648 - 2147483647	INT32 R/- - -	Modbus 7724

The following parameters let you read the maximum value of the load-dependent position deviation reached since the last power cycle.

Parameter name HMI menu HMI name	Description	Unit Minimum value Factory setting Maximum value	Data type R/W Persistent Expert	Parameter address via fieldbus
<i>_p_dif_load_peak_usr</i>	Maximum value of the load-dependent position deviation. This parameter contains the maximum load-dependent position deviation reached so far. A write access resets this value. Modified settings become active immediately. Available with firmware version $\geq V01.05$.	usr_p 0 - 2147483647	INT32 R/W - -	Modbus 7722

Setting the Maximum Values for the Position Deviation

The following parameter lets you set the threshold for the maximum load-dependent position deviation that is to trigger an error of error class 0.

Parameter name	Description	Unit	Data type	Parameter address via fieldbus
HMI menu		Minimum value	R/W	
HMI name		Factory setting	Persistent	
		Maximum value	Expert	
<i>MON_p_dif_warn</i>	Advisory limit of the load-dependent position deviation (error class 0). 100.0 % correspond to the maximum position deviation (following error) as specified by means of parameter <i>MON_p_dif_load</i> . Modified settings become active immediately.	% 0 75 100	UINT16 R/W per. -	Modbus 1618

The following parameters let you set the maximum load-dependent position deviation at which a movement is canceled with an error of error classes 1, 2, or 3.

Parameter name	Description	Unit	Data type	Parameter address via fieldbus
HMI menu		Minimum value	R/W	
HMI name		Factory setting	Persistent	
		Maximum value	Expert	
<i>MON_p_dif_load_usr</i>	Maximum load-dependent position deviation. The load-dependent position deviation is the difference between the reference position and the actual position caused by the load. The minimum value, the factory setting and the maximum value depend on the scaling factor. Modified settings become active immediately. Available with firmware version \geq V01.05.	usr_p 1 16384 2147483647	INT32 R/W per. -	Modbus 1660

Setting the Error Class

The following parameter lets you set the error class for an excessively high load-dependent position deviation.

Parameter name	Description	Unit	Data type	Parameter address via fieldbus
HMI menu		Minimum value	R/W	
HMI name		Factory setting	Persistent	
		Maximum value	Expert	
<i>ErrorResp_p_dif</i>	Error response to excessively high load-dependent position deviation. 1 / Error Class 1: Error class 1 2 / Error Class 2: Error class 2 3 / Error Class 3: Error class 3 Setting can only be modified if power stage is disabled. Modified settings become active the next time the power stage is enabled.	- 1 3 3	UINT16 R/W per. -	Modbus 1302

Load-Dependent Velocity Deviation

Description

The load-dependent velocity deviation is the difference between the reference velocity and the actual velocity caused by the load.

The maximum permissible load-dependent velocity deviation can be parameterized. In addition, you can set the error class.

Availability

Monitoring of the load-dependent velocity deviation is available in the following operating modes:

- Electronic Gear (velocity synchronization)
- Profile Velocity

Reading the Velocity Deviation

The following parameters let you read the load-dependent velocity deviation.

Parameter name HMI menu HMI name	Description	Unit Minimum value Factory setting Maximum value	Data type R/W Persistent Expert	Parameter address via fieldbus
<i>_v_dif_usr</i>	Load-dependent velocity deviation. The load-dependent velocity deviation is the difference between reference velocity and actual velocity. Available with firmware version \geq V01.26.	usr_v -2147483648 - 2147483647	INT32 R/- - -	Modbus 7768

Setting the Maximum Values for the Velocity Deviation

The following parameters let you specify the size of the window for the maximum load-dependent velocity deviation at which a movement is canceled.

Parameter name HMI menu HMI name	Description	Unit Minimum value Factory setting Maximum value	Data type R/W Persistent Expert	Parameter address via fieldbus
<i>MON_VeIDiff</i>	Maximum load-dependent velocity deviation. Value 0: Monitoring deactivated. Value >0: Maximum value Modified settings become active immediately. Available with firmware version \geq V01.26.	usr_v 0 0 2147483647	UINT32 R/W per. -	Modbus 1686
<i>MON_VeIDiff_Time</i>	Time window for maximum load-dependent velocity deviation. Value 0: Monitoring deactivated. Value >0: Time window for maximum value Modified settings become active immediately. Available with firmware version \geq V01.26.	ms 0 10 -	UINT16 R/W per. -	Modbus 1688

Setting the Error Class

The following parameter lets you set the error class for an excessively high load-dependent velocity deviation.

Parameter name	Description	Unit	Data type	Parameter address via fieldbus
HMI menu		Minimum value	R/W	
HMI name		Factory setting	Persistent	
		Maximum value	Expert	
<i>ErrorResp_v_dif</i>	Error response to excessively high load-dependent velocity deviation. 1 / Error Class 1: Error class 1 2 / Error Class 2: Error class 2 3 / Error Class 3: Error class 3 Setting can only be modified if power stage is disabled. Modified settings become active the next time the power stage is enabled. Available with firmware version \geq V01.26.	- 1 3 3	UINT16 R/W per. -	Modbus 1400

Motor Standstill and Direction of Movement

Availability

Monitoring depends on the firmware version

- Motor standstill: Available with firmware version \geq V01.00.
- Direction of movement: Available with firmware version \geq V01.14.

Description

The status of a movement can be monitored. You can determine whether the motor is at a standstill or whether it moves in a specific direction.

A velocity of <9 RPM is interpreted as standstill.

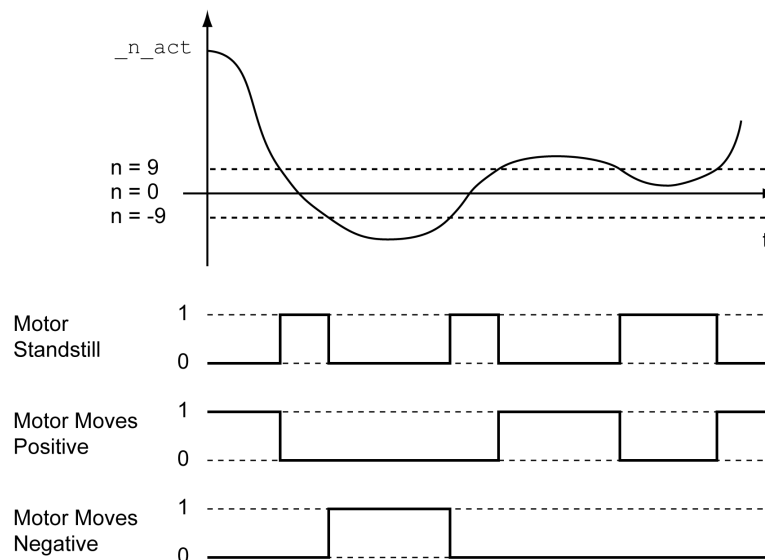

The status is available via signal outputs. In order to read the status, you must first parameterize the signal output functions “Motor Standstill”, “Motor Moves Positive”

or “Motor Moves Negative”, see Digital Signal Inputs and Digital Signal Outputs, page 169.

Position Deviation Window

Description

The position deviation window allows you to monitor whether the motor is within a parameterizable position deviation.

The position deviation is the difference between reference position and actual position.

The position deviation window comprises position deviation and monitoring time.

Availability

The position deviation window is available in the following operating modes.

- Jog
- Electronic Gear (position synchronization)

Settings

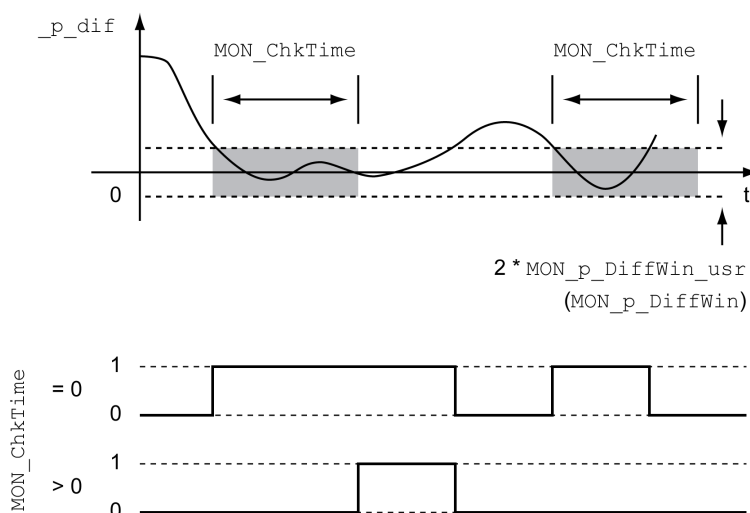

The parameters *MON_p_DiffWin_usr* and *MON_ChkTime* specify the size of the window.

Status Indication

The status is available via a signal output.

In order to read the status via a signal output, you must first parameterize the signal output function “In Position Deviation Window”, see Digital Signal Inputs and Digital Signal Outputs, page 169.

The parameter *MON_ChkTime* acts on the parameters *MON_p_DiffWin_usr* (*MON_p_DiffWin*), *MON_v_DiffWin*, *MON_v_Threshold* and *MON_I_Threshold*.

Parameter name HMI menu HMI name	Description	Unit Minimum value Factory setting Maximum value	Data type R/W Persistent Expert	Parameter address via fieldbus
<i>MON_p_DiffWin_usr</i>	Monitoring of position deviation. The system verifies whether the drive is within the defined deviation during the period set with <i>MON_ChkTime</i> . The status can be output via a parameterizable output. The minimum value, the factory setting and the maximum value depend on the scaling factor. Modified settings become active immediately. Available with firmware version $\geq V01.05$.	usr_p 0 16 2147483647	INT32 R/W per. -	Modbus 1662
<i>MON_ChkTime</i> <i>CONF → 1 - 0 -</i> <i>Et hr</i>	Monitoring of time window. Adjustment of a time for monitoring of position deviation, velocity deviation, velocity value and current value. If the monitored value is in the permissible range during the adjusted time, the monitoring function delivers a positive result. The status can be output via a parameterizable output. Modified settings become active immediately.	ms 0 0 9999	UINT16 R/W per. -	Modbus 1594

Velocity Deviation Window

Description

The velocity deviation window allows you to monitor whether the motor is within a parameterizable velocity deviation.

The velocity deviation is the difference between the reference velocity and the actual velocity.

The velocity deviation window comprises velocity deviation and monitoring time.

Availability

The velocity deviation window is available in the following operating modes.

- Jog
- Electronic Gear (velocity synchronization)
- Profile Velocity

Settings

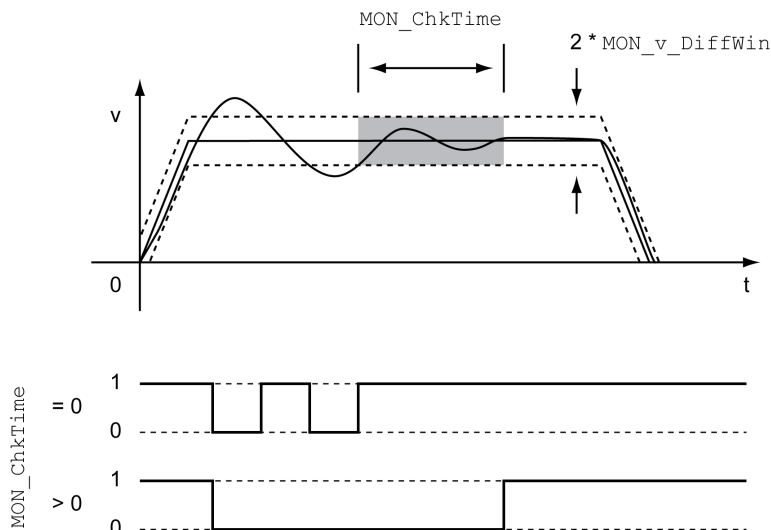

The parameters *MON_v_DiffWin* and *MON_ChkTime* specify the size of the window.

Status Indication

The status is available via a signal output.

In order to read the status via a signal output, you must first parameterize the signal output function "In Velocity Deviation Window", see *Digital Signal Inputs and Digital Signal Outputs*, page 169.

The parameter *MON_ChkTime* acts on the parameters *MON_p_DiffWin_usr*, *MON_v_DiffWin*, *MON_v_Threshold* and *MON_I_Threshold*.

Parameter name HMI menu HMI name	Description	Unit Minimum value Factory setting Maximum value	Data type R/W Persistent Expert	Parameter address via fieldbus
<i>MON_v_DiffWin</i>	Monitoring of velocity deviation. The system monitors whether the drive is within the defined deviation during the period set with <i>MON_ChkTime</i> . The status can be output via a parameterizable output. Modified settings become active immediately.	usr_v 1 10 2147483647	UINT32 R/W per. -	Modbus 1588
<i>MON_ChkTime</i> <i>CONF → 1 - 0 -</i> <i>LEHR</i>	Monitoring of time window. Adjustment of a time for monitoring of position deviation, velocity deviation, velocity value and current value. If the monitored value is in the permissible range during the adjusted time, the monitoring function delivers a positive result. The status can be output via a parameterizable output. Modified settings become active immediately.	ms 0 0 9999	UINT16 R/W per. -	Modbus 1594

Velocity Threshold Value

Description

The velocity threshold value allows you to monitor whether the actual velocity is below a parameterizable velocity value.

The velocity threshold value comprises the velocity and the monitoring time.

Settings

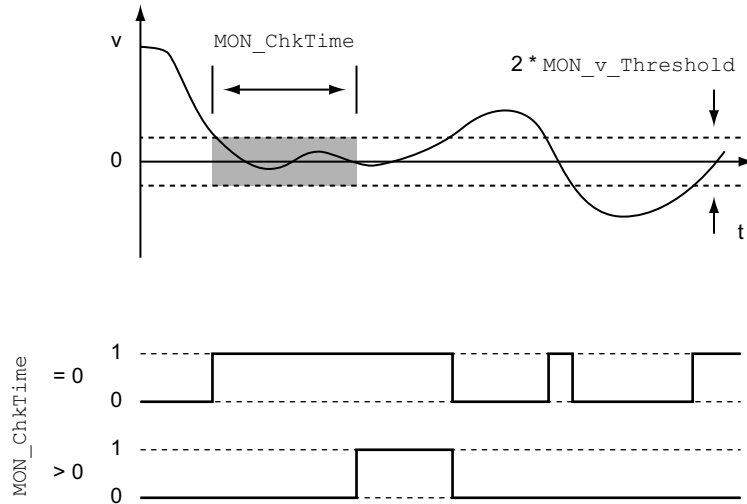

The parameters $MON_v_Threshold$ and $MON_ChkTime$ specify the size of the window.

Status Indication

The status is available via a signal output.

In order to read the status via a signal output, you must first parameterize the signal output function "Velocity Below Threshold", see Digital Signal Inputs and Digital Signal Outputs, page 169.

The parameter $MON_ChkTime$ acts on the parameters $MON_p_DiffWin_usr$, $MON_v_DiffWin$, $MON_v_Threshold$ and $MON_I_Threshold$.

Parameter name	Description	Unit	Data type	Parameter address via fieldbus
HMI menu HMI name		Minimum value Factory setting Maximum value	R/W Persistent Expert	
<i>MON_v_Threshold</i>	Monitoring of velocity threshold. The system monitors whether the drive is below the defined value during the period set with <i>MON_ChkTime</i> . The status can be output via a parameterizable output. Modified settings become active immediately.	usr_v 1 10 2147483647	UINT32 R/W per. -	Modbus 1590
<i>MON_ChkTime</i> <i>CONF → i - o -</i> <i>Ether</i>	Monitoring of time window. Adjustment of a time for monitoring of position deviation, velocity deviation, velocity value and current value. If the monitored value is in the permissible range during the adjusted time, the monitoring function delivers a positive result. The status can be output via a parameterizable output. Modified settings become active immediately.	ms 0 0 9999	UINT16 R/W per. -	Modbus 1594

Current Threshold Value

Description

The current threshold value allows you to monitor whether the actual current is below a parameterizable current value.

The current threshold value comprises the current value and the monitoring time.

Settings

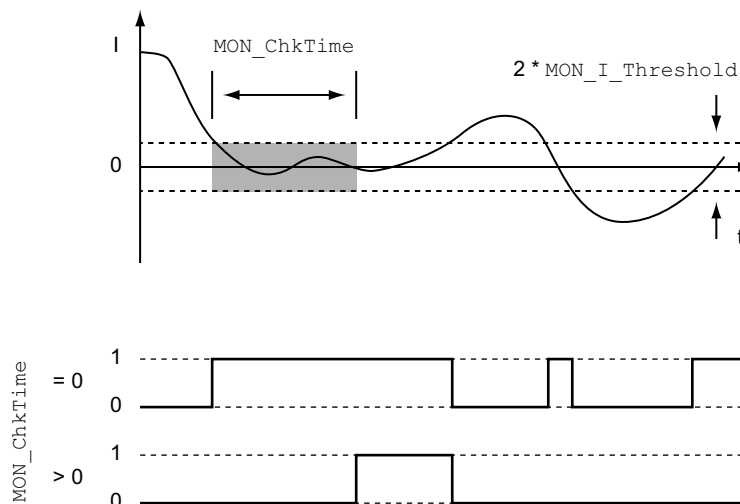

The parameters *MON_I_Threshold* and *MON_ChkTime* specify the size of the window.

Status Indication

The status is available via a signal output.

In order to read the status via a signal output, you must first parameterize the signal output function "Current Below Threshold", see Digital Signal Inputs and Digital Signal Outputs, page 169.

The parameter *MON_ChkTime* acts on the parameters *MON_p_DiffWin_usr*, *MON_v_DiffWin*, *MON_v_Threshold* and *MON_I_Threshold*.

Parameter name	Description	Unit	Data type	Parameter address via fieldbus
HMI menu		Minimum value	R/W	
HMI name		Factory setting	Persistent	
		Maximum value	Expert	
<i>MON_I_Threshold</i> <i>CONF → I - 0 -</i> <i>thr</i>	<p>Monitoring of current threshold.</p> <p>The system monitors whether the drive is below the defined value during the period set with <i>MON_ChkTime</i>.</p> <p>The status can be output via a parameterizable output.</p> <p>The parameter <i>_Iq_act_rms</i> is used as comparison value.</p> <p>In increments of 0.01 A_{rms}.</p> <p>Modified settings become active immediately.</p>	<p>A_{rms}</p> <p>0.00</p> <p>0.20</p> <p>300.00</p>	<p>UINT16</p> <p>R/W</p> <p>per.</p> <p>-</p>	Modbus 1592
<i>MON_ChkTime</i> <i>CONF → I - 0 -</i> <i>tkr</i>	<p>Monitoring of time window.</p> <p>Adjustment of a time for monitoring of position deviation, velocity deviation, velocity value and current value. If the monitored value is in the permissible range during the adjusted time, the monitoring function delivers a positive result.</p> <p>The status can be output via a parameterizable output.</p> <p>Modified settings become active immediately.</p>	<p>ms</p> <p>0</p> <p>0</p> <p>9999</p>	<p>UINT16</p> <p>R/W</p> <p>per.</p> <p>-</p>	Modbus 1594

Functions for Monitoring Internal Device Signals

Temperature Monitoring

Temperature of Power Stage

The parameter *_PS_T_current* indicates the temperature of the power stage.

The parameter *_PS_T_warn* contains the threshold value for an error of error class 0. The parameter *_PS_T_max* indicates the maximum power stage temperature.

Parameter name HMI menu HMI name	Description	Unit Minimum value Factory setting Maximum value	Data type R/W Persistent Expert	Parameter address via fieldbus
<i>_PS_T_current</i> Π ο η ε P S	Temperature of power stage.	°C - - -	INT16 R/- - -	Modbus 7200
<i>_PS_T_warn</i>	Advisory temperature limit of power stage (error class 0).	°C - - -	INT16 R/- per. -	Modbus 4108
<i>_PS_T_max</i>	Maximum temperature of power stage.	°C - - -	INT16 R/- per. -	Modbus 4110

Temperature of Motor

The parameter *_M_T_current* indicates the motor temperature.

The parameter *_M_T_max* indicates the maximum motor temperature.

Parameter name HMI menu HMI name	Description	Unit Minimum value Factory setting Maximum value	Data type R/W Persistent Expert	Parameter address via fieldbus
<i>_M_T_current</i> Π ο η ε Π ο ε	Temperature of motor.	°C - - -	INT16 R/- - -	Modbus 7202
<i>_M_T_max</i>	Maximum temperature of motor.	°C - - -	INT16 R/- - -	Modbus 3360

Monitoring Load and Overload (I²T Monitoring)

Description

The load is the thermal load on the power stage, the motor and the braking resistor.

Load and overload on the individual components are monitored internally; the values can be read by means of parameters.

Overload starts at a load value of 100 %.

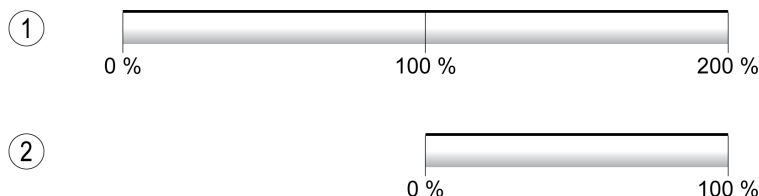

1 Load

2 Overload

Load Monitoring

The load can be read using the following parameters:

Parameter name	Description	Unit	Data type	Parameter address via fieldbus
HMI menu		Minimum value	R/W	
HMI name		Factory setting	Persistent	
		Maximum value	Expert	
<i>_PS_load</i>	Load of power stage.	%	INT16	Modbus 7214
<i>Π ο η</i>		-	R/-	
<i>L d F P</i>		-	-	
		-	-	
<i>_M_load</i>	Load of motor.	%	INT16	Modbus 7220
<i>Π ο η</i>		-	R/-	
<i>L d F Π</i>		-	-	
		-	-	
<i>_RES_load</i>	Load of braking resistor.	%	INT16	Modbus 7208
<i>Π ο η</i>	The braking resistor set via parameter RESint_ext is monitored.	-	R/-	
<i>L d F b</i>		-	-	
		-	-	

Overload Monitoring

In the case of 100 % overload of the power stage or the motor, the current is limited internally. In the case of 100 % overload of the braking resistor, the braking resistor is deactivated.

The overload and the peak value can be read using the following parameters:

Parameter name HMI menu HMI name	Description	Unit Minimum value Factory setting Maximum value	Data type R/W Persistent Expert	Parameter address via fieldbus
<i>_PS_overload</i>	Overload of power stage.	% - - -	INT16 R/- - -	Modbus 7240
<i>_PS_maxoverload</i>	Maximum value of overload of power stage. Maximum overload of power stage during the last 10 seconds.	% - - -	INT16 R/- - -	Modbus 7216
<i>_M_overload</i>	Overload of motor (I2t).	% - - -	INT16 R/- - -	Modbus 7218
<i>_M_maxoverload</i>	Maximum value of overload of motor. Maximum overload of motor during the last 10 seconds.	% - - -	INT16 R/- - -	Modbus 7222
<i>_RES_overload</i>	Overload of braking resistor (I2t). The braking resistor set via parameter RESint_ext is monitored.	% - - -	INT16 R/- - -	Modbus 7206
<i>_RES_maxoverload</i>	Maximum value of overload of braking resistor. Maximum overload of braking resistor during the last 10 seconds. The braking resistor set via parameter RESint_ext is monitored.	% - - -	INT16 R/- - -	Modbus 7210

Commutation Monitoring

Description

Commutation monitoring verifies the plausibility of acceleration and effective motor torque.

If the motor accelerates though the drive control decelerates the motor with the maximum current, an error is detected.

Deactivating commutation monitoring can cause unintended movements.

▲ WARNING

UNINTENDED MOVEMENT

- Only deactivate commutation monitoring during commissioning and only for test purposes.
- Verify that the commutation monitoring is active prior to putting the equipment into service.

Failure to follow these instructions can result in death, serious injury, or equipment damage.

The parameter *MON_commutat* lets you deactivate commutation monitoring.

Parameter name	Description	Unit	Data type	Parameter address via fieldbus
HMI menu		Minimum value	R/W	
HMI name		Factory setting	Persistent	
		Maximum value	Expert	
<i>MON_commutat</i>	Commutation monitoring. 0 / Off: Commutation monitoring off 1 / On: Commutation monitoring on in operating states 6, 7 and 8 2 / On (OpState6+7): Commutation monitoring on in operating states 6 and 7 Setting can only be modified if power stage is disabled. Modified settings become active the next time the power stage is enabled.	- 0 1 2	UINT16 R/W per. -	Modbus 1290

Monitoring of Mains Phases

Description

If a three-phase drive is missing a mains phase and mains phase monitoring is not correctly set, this can cause overload of the product.

NOTICE
<p>INOPERABLE EQUIPMENT DUE TO MISSING MAINS PHASE</p> <ul style="list-style-type: none"> Verify that mains phase monitoring is set to "Automatic Mains Detection" or to "Mains ..." with the correct voltage value if the drive is supplied via the mains phases. Verify that mains phase monitoring is set to "DC bus only ..." with the correct voltage value if the drive is supplied via the DC bus. <p>Failure to follow these instructions can result in equipment damage.</p>

NOTE: The mains phases are only monitored in the operating states **5** Switched On, **6** Operation Enabled, **7** Quick Stop Active, and **8** Fault Reaction Active.

The parameter *ErrorResp_Flt_AC* lets you set the error response to a missing mains phase for three-phase devices.

Parameter name	Description	Unit	Data type	Parameter address via fieldbus
HMI menu		Minimum value	R/W	
HMI name		Factory setting	Persistent	
		Maximum value	Expert	
<i>ErrorResp_Flt_AC</i>	Error response to missing mains phase. 0 / Error Class 0: Error class 0 1 / Error Class 1: Error class 1 2 / Error Class 2: Error class 2 3 / Error Class 3: Error class 3 Setting can only be modified if power stage is disabled. Modified settings become active the next time the power stage is enabled.	- 0 2 3	UINT16 R/W per. -	Modbus 1300

If the product is supplied via the DC bus, mains phase monitoring must be set to "DC bus only ..." with the correct voltage value.

Mains phase monitoring is set by means of the parameter *MON_MainsVolt*.

Parameter name HMI menu HMI name	Description	Unit Minimum value Factory setting Maximum value	Data type R/W Persistent Expert	Parameter address via fieldbus
<i>MON_MainsVolt</i>	<p>Detection and monitoring of mains phases.</p> <p>0 / Automatic Mains Detection: Automatic detection and monitoring of mains voltage</p> <p>1 / DC-Bus Only (Mains 1~230 V / 3~480 V): DC bus supply only, corresponding to mains voltage 230 V (single-phase) or 480 V (three phases)</p> <p>2 / DC-Bus Only (Mains 1~115 V / 3~208 V): DC bus supply only, corresponding to mains voltage 115 V (single-phase) or 208 V (three phases)</p> <p>3 / Mains 1~230 V / 3~480 V: Mains voltage 230 V (single-phase) or 480 V (three phases)</p> <p>4 / Mains 1~115 V / 3~208 V: Mains voltage 115 V (single-phase) or 208 V (three phases)</p> <p>5 / Reserved: Reserved</p> <p>Value 0: As soon as mains voltage detected, the device automatically verifies whether the mains voltage is 115 V or 230 V in the case of single-phase devices or 208 V or 400/480 V in the case of three-phase devices.</p> <p>Values 1 ... 2: If the device is supplied only via the DC bus, the parameter has to be set to the voltage value corresponding to the mains voltage of the supplying device. There is no mains voltage monitoring.</p> <p>Values 3 ... 4: If the mains voltage is not detected properly during start-up, the mains voltage to be used can be selected manually.</p> <p>Setting can only be modified if power stage is disabled.</p> <p>Modified settings become active the next time the power stage is enabled.</p>	- 0 0 5	UINT16 R/W per. expert	Modbus 1310

Ground Monitoring

Description

When the power stage is enabled, the device monitors the motor phases for ground errors. A ground error occurs when one or more motor phases are short-circuited to the ground (earth) of the application.

A ground error of one or more motor phases is detected. A ground error of the DC bus or the braking resistor is not monitored.

If the ground error monitoring is deactivated, the drive may be rendered inoperable by a ground error.

NOTICE

INOPERABLE EQUIPMENT DUE TO GROUND ERRORS

- Only deactivate ground monitoring during commissioning and only for test purposes.
- Verify that the ground monitoring is active prior to putting the equipment into service.

Failure to follow these instructions can result in equipment damage.

Parameter name HMI menu HMI name	Description	Unit Minimum value Factory setting Maximum value	Data type R/W Persistent Expert	Parameter address via fieldbus
<i>MON_GroundFault</i>	Ground monitoring. 0 / Off: Ground monitoring off 1 / On: Ground monitoring on Modified settings become active the next time the product is powered on.	- 0 1 1	UINT16 R/W per. expert	Modbus 1312

Examples

Examples

General Information

The examples show some typical applications of the product. The examples are intended to provide an overview; they are not exhaustive wiring plans.

The examples described here are intended for learning purposes only. In general, they are intended to help you understand how to develop, test, commission, and integrate application logic and/or the device wiring of the equipment associated with your own design in your control systems. The examples are not intended to be used directly on products that are part of a machine or process.

▲ WARNING

UNINTENDED EQUIPMENT OPERATION

Do not include any wiring information, programming or configuration logic, or parameterization values from the Examples in your machine or process without thoroughly testing your entire application.

Failure to follow these instructions can result in death, serious injury, or equipment damage.

Using the safety function STO integrated in this product requires careful planning. See section Functional Safety, page 71 for additional information.

Example of Operating Mode Electronic Gear

Reference values are provided in the form of A/B signals.

Wiring example

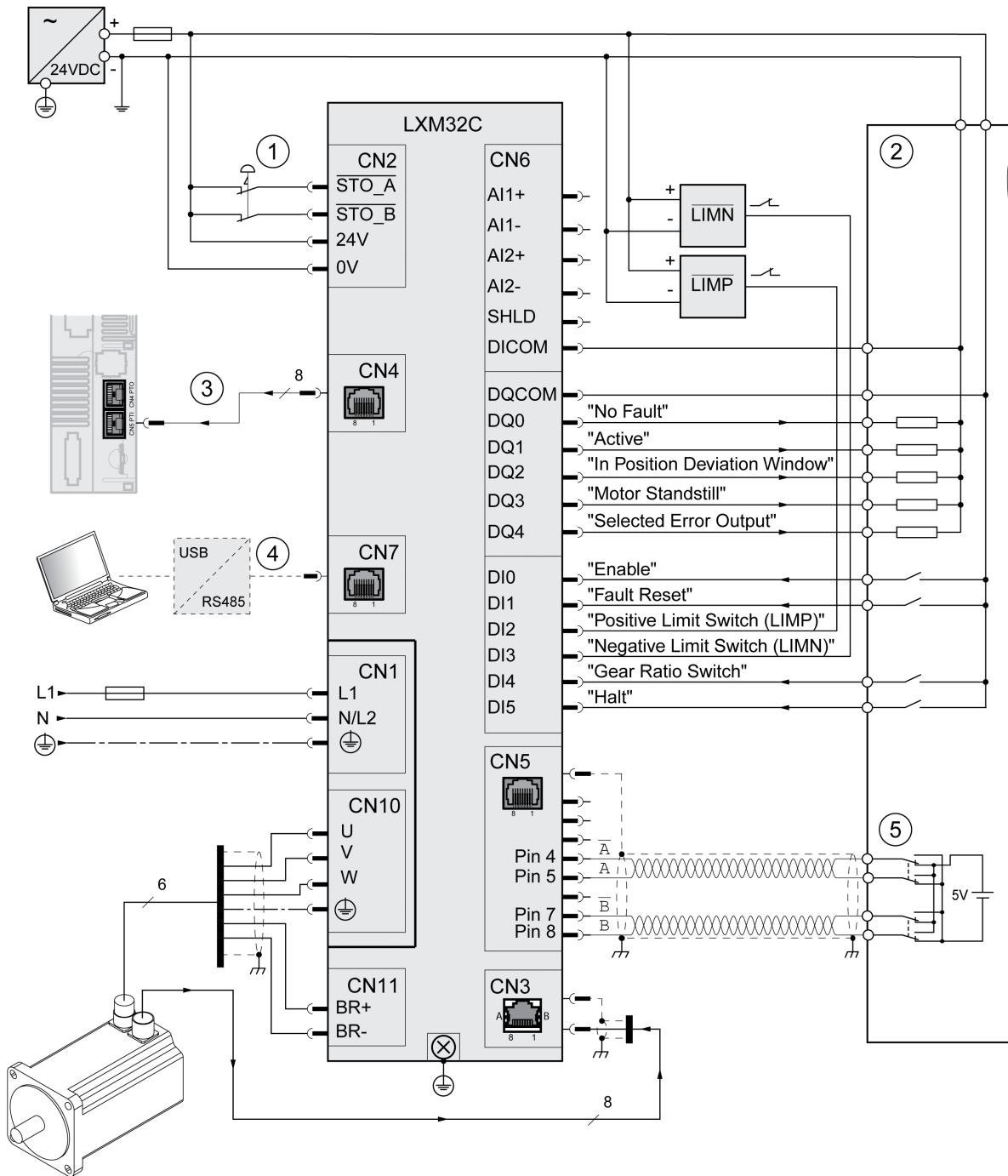

- 1 EMERGENCY STOP
- 2 Controller
- 3 PTO - Encoder simulation (ESIM)
- 4 Commissioning accessories
- 5 Signal source for A/B signals

Example of Operating Mode Profile Velocity

Reference values are provided via a $\pm 10V$ analog signal.

Wiring example

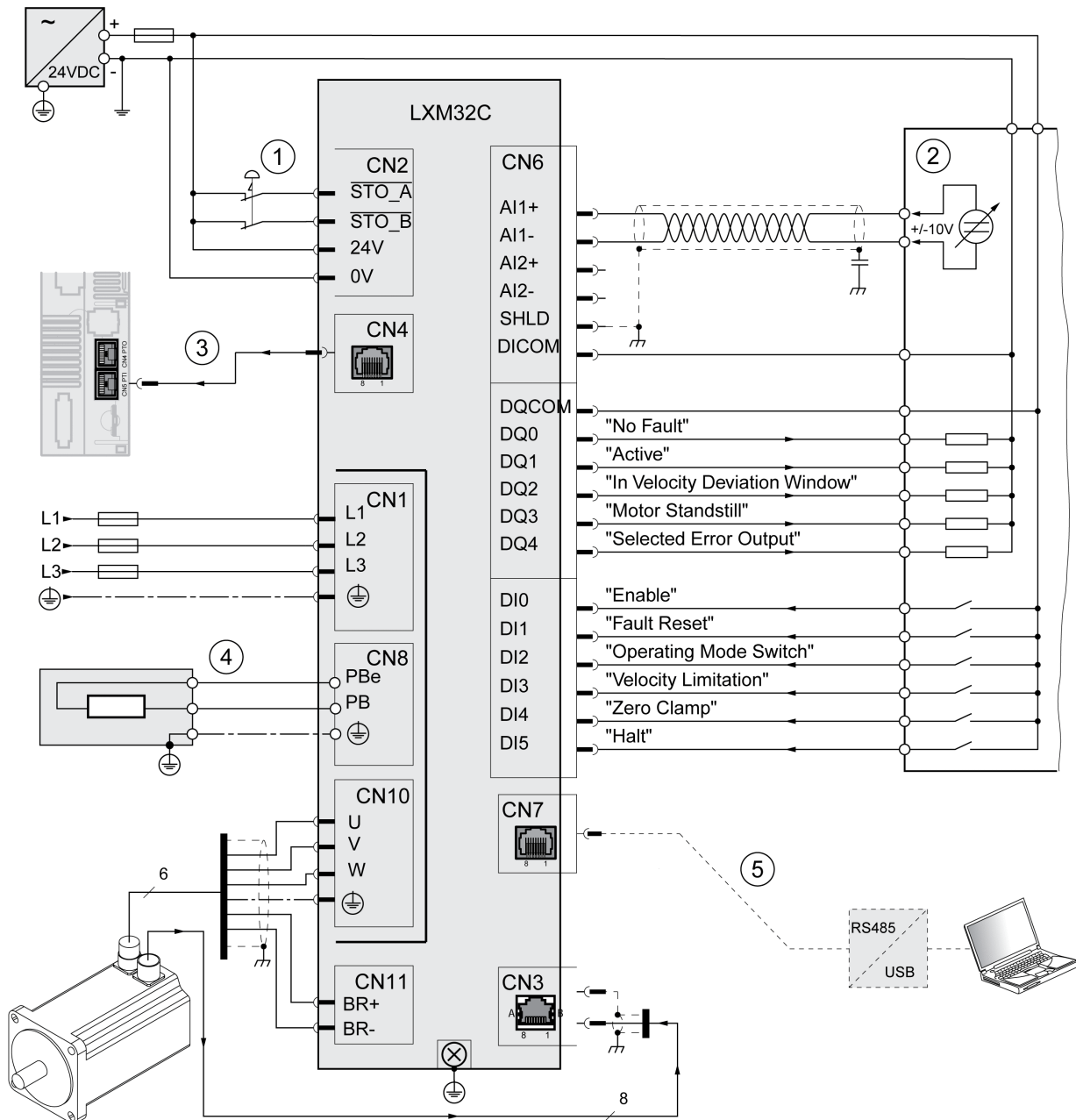

1 EMERGENCY STOP

2 Controller

3 PTO - Encoder simulation (ESIM)

4 External braking resistor

5 Commissioning accessories

Diagnostics and Troubleshooting

Diagnostics via HMI

Diagnostics via the Integrated HMI

Overview

The 7-segment display provides the user with information.

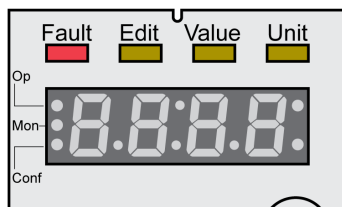

With the factory setting, the 7-segment display shows the operating states. The operating states are described in section *Operating States*, page 202.

Message	Description
<i>o n i t</i>	Operating state 1 Start
<i>n r d y</i>	Operating state 2 Not Ready To Switch On
<i>d i s</i>	Operating state 3 Switch On Disabled
<i>r d y</i>	Operating state 4 Ready To Switch On
<i>s o n</i>	Operating state 5 Switched On
<i>r u n</i> and <i>h A L t</i>	Operating state 6 Operation Enabled
<i>S t o P</i>	Operating state 7 Quick Stop Active
<i>F L t</i>	Operating state 8 Fault Reaction Active and 9 Fault

Additional Messages

The table below provides an overview of the messages that can additionally be displayed on the integrated HMI.

Message	Description
<i>C A r d</i>	Data on the memory card differs from data in the product. See <i>Memory Card</i> , page 157 for information on how to proceed.
<i>d i S P</i>	An external HMI is connected. The integrated HMI has no function.
<i>n o t</i>	A new motor was detected. See section <i>Acknowledging a Motor Change</i> , page 273 for replacing a motor.
<i>P r o t</i>	Parts of the integrated HMI were locked with the parameter <i>HMIlocked</i> .
<i>u L o W</i>	24 Vdc control supply during initialization not high enough.
<i>B B B B</i>	Undervoltage 24 Vdc control supply.
<i>W d o G</i>	Undeterminable system error. Contact your Schneider Electric representative.
<i>- - - -</i>	Firmware not available. Retry to flash the firmware. If the condition persists, contact your Schneider Electric representative.

If the HMI displays a message that is not contained in this user guide, contact your Schneider Electric representative.

Acknowledging a Motor Change

Description

Procedure for confirming a motor change via the integrated HMI.

If the 7-segment display shows $\Pi \square E$:

- Press the navigation button.
The 7-segment display shows $S R V E$.
- Press the navigation button to save the new motor parameters to the nonvolatile memory.

The drive switches to operating state **4** Ready To Switch On.

Confirming a motor change via the integrated HMI

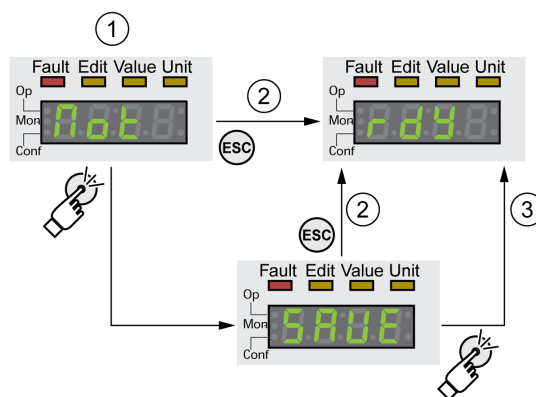

1 HMI displays that a replacement of a motor has been detected.

2 Canceling the saving process

3 Saving switching to operating state **4** Ready To Switch On.

Displaying Error Messages via the HMI

Resetting Errors of Error Class 0

If there are errors of error class 0, the two dots to the right of the 7-segment display (2) flash. The error code is not directly displayed on the 7-segment display, but must be explicitly queried by the user.

Procedure for displaying and resetting:

- Press the navigation button and hold it down.
The 7-segment display shows the error code.
- Release the navigation button.
The 7-segment display shows $F r E 5$.
- Remedy the cause.
- Press the navigation button to reset the error message.
The 7-segment display returns to the initial state.

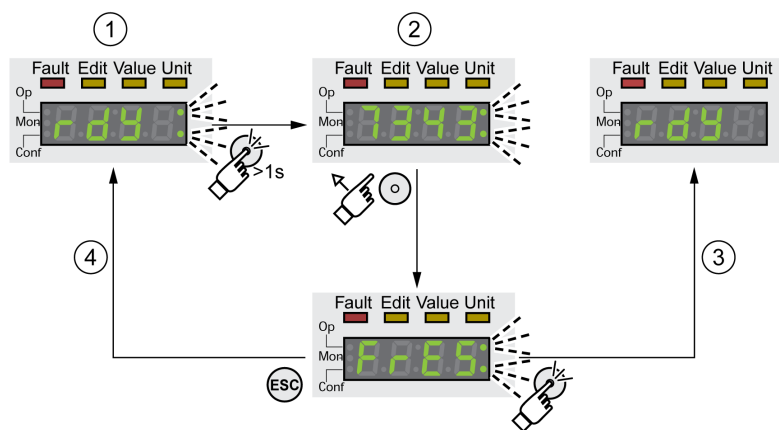

- 1 HMI shows an error of error class 0
- 2 Indication of error code
- 3 Resetting an error message
- 4 Canceling (the error code remains in the memory)

See Error Messages, page 277 for the meaning of the error codes.

Reading and Acknowledging Errors of Error Classes 1 ...4

In the case of a detected error of error class 1, the error code and *S E O P* are alternately shown on the 7 segment display.

In the case of a detected error of error class 2 ... 4, the error code and *F L E* are alternately shown on the 7 segment display.

Procedure for displaying and resetting:

- Remedy the cause.
- Press the navigation button.
The 7-segment display shows *F r E 5*.
- Press the navigation button to reset the error message.
The product switches to operating state 4 Ready To Switch On.

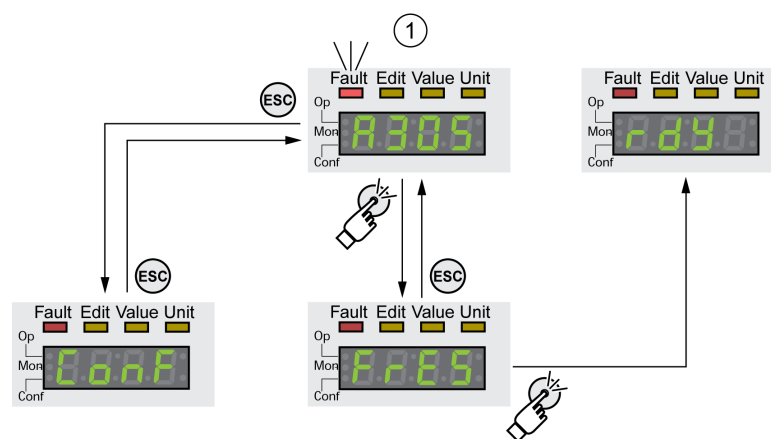

- 1 HMI shows and error message with an error code

See Error Messages, page 277 for the meaning of the error codes.

Diagnostics via Signal Outputs

Indicating the Operating State

Description

Information on the operating state is available via the signal outputs.

The table below provides an overview.

Operating state	Signal output function	
	“No fault” ⁽¹⁾	“Active” ⁽²⁾
1 Start	0	0
2 Not Ready To Switch On	0	0
3 Switch On Disabled	0	0
4 Ready To Switch On	1	0
5 Switched On	1	0
6 Operation Enabled	1	1
7 Quick Stop Active	0	0
8 Fault Reaction Active	0	0
9 Fault	0	0
(1) The signal output function is factory setting for signal output DQ0		
(2) The signal output function is the factory setting for signal output DQ1		

Indicating Error Messages

Description

Selected error messages can be output via the signal outputs.

In order to output an error message via a signal output, you must first parameterize the signal output functions “Selected Warning” or “Selected Error”, see Digital Signal Inputs and Digital Signal Outputs, page 169.

The parameters *MON_IO_SelWar1* and *MON_IO_SelWar2* are used to specify error codes with the error class 0.

The parameters *MON_IO_SelErr1* and *MON_IO_SelErr2* are used to specify error codes with the error classes 1 ... 4.

If an error specified in one of these parameters is detected, the corresponding signal output is to be set.

The list of the error messages sorted by error code can be found in the section Error Messages, page 277.

Parameter name HMI menu HMI name	Description	Unit Minimum value Factory setting Maximum value	Data type R/W Persistent Expert	Parameter address via fieldbus
<i>MON_IO_SelWar1</i>	Signal output function Selected Warning (error class 0): First error code. This parameter specifies the error code of an error of error class 0 which is to activate the signal output function. Modified settings become active immediately.	- 0 0 65535	UINT16 R/W per. -	Modbus 15120
<i>MON_IO_SelWar2</i>	Signal output function Selected Warning (error class 0): Second error code. This parameter specifies the error code of an error of error class 0 which is to activate the signal output function. Modified settings become active immediately.	- 0 0 65535	UINT16 R/W per. -	Modbus 15122
<i>MON_IO_SelErr1</i>	Signal output function Selected Error (error classes 1 to 4): First error code. This parameter specifies the error code of an error of error classes 1 ... 4 which is to activate the signal output function. Modified settings become active immediately.	- 0 0 65535	UINT16 R/W per. -	Modbus 15116
<i>MON_IO_SelErr2</i>	Signal output function Selected Error (error classes 1 to 4): Second error code. This parameter specifies the error code of an error of error classes 1 ... 4 which is to activate the signal output function. Modified settings become active immediately.	- 0 0 65535	UINT16 R/W per. -	Modbus 15118

Error Messages

Description of Error Messages

Description

If monitoring functions of the drive detect an error, the drive generates an error message. Each error message is identified by an error code.

The following information is available for each error message:

- Error code
- Error class
- Description of error
- Possible causes
- Possible remedies

Range of Error Messages

The table below summarizes the error codes classified by range.

Error code	Range
E 1xxx	General
E 2xxx	Overcurrent
E 3xxx	Voltage
E 4xxx	Temperature
E 5xxx	Hardware
E 6xxx	Software
E 7xxx	Interface, wiring
E Axxx	Motor movement
E Bxxx	Communication

Error Class of Error Messages

The error messages are classified according to the following error classes:

Error class	State transition ⁽¹⁾	Error response	Resetting the error message
0	-	No interruption of the movement	Function "Fault Reset"
1	T11	Stop movement with "Quick Stop"	Function "Fault Reset"
2	T13, T14	Stop movement with "Quick Stop" and disable the power stage when the motor has come to a standstill	Function "Fault Reset"
3	T13, T14	Disable the power stage immediately without stopping the movement first	Function "Fault Reset"
4	T13, T14	Disable the power stage immediately without stopping the movement first	Power cycle

(1) See section Operating States, page 202.

Table of Error Messages

List of the Error Messages Sorted by Error Code

Error code	Error class	Description	Cause	Correctives
1100	0	Parameter out of permissible value range	The value entered was outside of the permissible value range for this parameter.	The entered value must be within the permissible value range.
1101	0	Parameter does not exist	Error detected by parameter management: Parameter (index) does not exist.	Select a different parameter (index).
1102	0	Parameter does not exist	Error detected by parameter management: Parameter (subindex) does not exist.	Select a different parameter (subindex).
1103	0	Parameter write not permissible (READ only)	Write access to read only parameter.	Write only to parameters that are not read-only.
1104	0	Write access denied (no access authorization)	Parameter only accessible at expert level.	The write access level expert is required.
1105	0	Block Upload/Download not initialized	-	-
1106	0	Command not permissible while power stage is active	Command not permissible while the power stage is enabled (operating state Operation Enabled or Quick Stop Active).	Disable the power stage and repeat the command.
1107	0	Access via other interface blocked	Access occupied by another channel (for example: Commissioning software is active and fieldbus access was tried at the same time).	Verify the channel that blocks access.
1108	0	File cannot be uploaded: Incorrect file ID	-	-
1109	1	Data stored after a power outage is invalid	-	-
110A	0	System error detected: No bootloader available	-	-
110B	3	Configuration error detected. Additional information in the error memory indicates the Modbus register address. Parameter <i>_SigLatched</i> Bit 30	Error detected during parameter check (for example, reference velocity value for operating mode Profile Position is greater than maximum permissible velocity of drive).	Value in additional error information shows the Modbus register address of the parameter where the initialization error was detected.
110D	1	Basic configuration of drive required after factory setting	The "First Setup" (FSU) was not run at all or not completed.	Perform a First Setup.
110E	0	Parameter changed that requires a restart of the drive	Only displayed by the commissioning software. A parameter modification requires the drive to be powered off and on.	Restart the drive to activate the parameter functionality. See the section Parameters for the parameter that requires a restart of the drive.
110F	0	Function not available in this type of device	The specific type of device does not support this function or this parameter value.	Verify that you have the correct device type, in particular type of motor, type of encoder, holding brake.
1110	0	Incorrect file ID for upload or download	The specific type of device does not support this kind of file.	Verify that you have the correct device type or the correct configuration file.
1111	0	File transfer not correctly initialized	A previous file transfer has been aborted.	-
1112	0	Locking of configuration denied	An external tool has tried to lock the configuration of the drive for upload or download. This may not work because another tool had already locked the configuration of the drive or the drive is in an operating state that does not allow locking.	-

Error code	Error class	Description	Cause	Correctives
1113	0	System not locked for configuration transfer	An external tool has tried to transfer the configuration without locking the drive.	-
1114	4	Configuration download aborted Parameter_ <i>SigLatched</i> Bit 5	During a configuration download, a communication error or an error in the external tool was detected. The configuration was only partially transferred to the drive and might be inconsistent now.	Power the drive off/on and retry to download the configuration or restore the factory settings.
1115	0	Incorrect configuration file format Parameter_ <i>WarnLatched</i> Bit 5	An external tool has downloaded a configuration which has an incorrect format.	-
1116	0	Request is processed asynchronously	-	-
1117	0	Asynchronous request blocked	Request to a module is blocked because the module is currently processing another request.	-
1118	0	Configuration data incompatible with device	The configuration data contains data from a different device.	Verify device type including type of power stage.
1119	0	Incorrect data length, too many bytes	-	-
111A	0	Incorrect data length, insufficient number of bytes	-	-
111B	4	Configuration download error detected. Additional information in the error memory indicates the Modbus register address.	During a configuration download, one or more configuration values were not accepted by the drive.	Verify that the configuration file is valid and matches the type and version of the drive. The value in the additional error info shows the Modbus register address of the parameter where the initialization error was detected.
111C	1	Not possible to initialize recalculation for scaling	A parameter could not be initialized.	The address of the parameter that caused the detected error can be read via the parameter <i>_PAR_ScalingError</i> .
111D	3	Original state of a parameter cannot be restored after an error was detected during recalculation of parameters with user-defined units.	The drive contained an invalid configuration before the recalculation was started. An error was detected during the recalculation.	Power the drive off and on again. This may help you to identify the affected parameter(s). Change the parameters as required. Verify that the parameter configuration is valid before starting the recalculation procedure.
111F	1	Recalculation not possible.	Invalid scaling factor.	Verify that you really want the selected scaling factor. Try a different scaling factor. Before triggering scaling, reset the parameters with user-defined units.
1120	1	Recalculation for scaling not possible	A parameter could not be recalculated.	The address of the parameter that caused this condition can be read via the parameter <i>_PAR_ScalingError</i> .
1121	0	Incorrect sequence of steps for scaling (fieldbus)	The recalculation has been started prior to the initialization.	The recalculation must be started after the initialization.
1122	0	Recalculation for scaling not possible	Recalculation for scaling is already running.	Wait for the running recalculation for scaling to finish.
1123	0	Parameter cannot be changed	Recalculation for scaling is running.	Wait for the running recalculation for scaling to finish.
1124	1	Timeout during recalculation for scaling	The time between the initialization of the recalculation and the start of the recalculation has been exceeded (30 seconds).	Recalculation must be started within 30 seconds after initialization.
1125	1	Scaling not possible	The scaling factors for position, velocity or acceleration/deceleration are beyond internal calculation limits.	Retry with different scaling factors.
1126	0	Configuration is blocked by another access channel	-	Close other access channel (for example, other instance of commissioning software).

Error code	Error class	Description	Cause	Correctives
1127	0	Invalid key received	-	-
1128	0	Special login is required for Manufacturing Test Firmware	-	-
1129	0	Test step not yet started	-	-
1132	0	Incorrect size of configuration file (odd number of bytes)	Incorrect number of bytes.	Retry. If the condition persists, contact your Schneider Electric service representative.
1300	3	Safety function STO activated (STO_A, STO_B) Parameter <i>_SigLatched</i> Bit 10	The safety function STO was activated in the operating state Operation Enabled.	Verify correct wiring of the inputs of the safety function STO and perform a Fault Reset.
1301	4	STO_A and STO_B different level Parameter <i>_SigLatched</i> Bit 11	The levels of the inputs STO_A and STO_B were different for more than 1 second.	Verify correct wiring of the inputs of the safety function STO.
1302	0	Safety function STO activated (STO_A, STO_B) Parameter <i>_WarnLatched</i> Bit 10	Safety function STO was activated while the power stage was disabled.	Verify correct wiring of the inputs of the safety function STO.
1310	2	Frequency of the external reference value signal too high Parameter <i>_SigLatched</i> Bit 28	The frequency of the external reference value signals (A/B signals, P/D signals or CW/CCW signals) is higher than the permissible value.	Verify the frequency of the external reference values. Verify the gear ratio in the operating mode Electronic Gear.
1311	0	The selected signal input function or signal output function cannot be configured	The selected signal input function or signal output function cannot be used in the selected operating mode.	Select another function or change the operating mode.
1312	0	Limit switch or reference switch signal not defined for signal input function	Reference movements require limit switches. These limit switches are not assigned to inputs.	Assign the signal input functions Positive Limit Switch, Negative Limit Switch and Reference Switch.
1313	0	Configured debounce time not possible for this signal input function	The signal input function does not support the selected debounce time.	Set the debounce time to a valid value.
1314	4	At least two inputs have the same signal input function.	The same signal input function has been assigned to at least two inputs.	Reconfigure the inputs.
1315	0	Frequency of reference value signal is too high. Parameter <i>_WarnLatched</i> Bit 28	The frequency of the pulse signal (A/B, Pulse/Direction, CW/CCW) exceeds the specified range. Received pulses may be lost.	Adapt the frequency of the reference value signal to match the input specification of the drive. Also adapt the gear ratio in the operating mode Electronic Gear to the application requirements (position accuracy and velocity).
1316	1	Position capture via signal input currently not possible Parameter <i>_SigLatched</i> Bit 28	Position capture is already being used.	-
1317	0	Interference at PTI input Parameter <i>_WarnLatched</i> Bit 28	Interfering pulses or impermissible edge transitions (A and B signal simultaneously) have been detected.	Verify cable specifications, shield connection and EMC.
1318	0	The selected type of usage of the analog inputs is not possible.	At least two analog inputs are configured with the same type of usage.	Reconfigure the analog inputs.
1501	4	System error detected: DriveCom state machine indeterminable state	-	-
1502	4	System error detected: HWL low-level state machine indeterminable state	-	-
1503	1	Quick Stop triggered via fieldbus	A Quick Stop has been triggered via the fieldbus. The Quick Stop option code has been set to -1 or -2 which causes the drive to transition to the operating state 9 Fault instead of the operating state 7 Quick Stop Active.	-
1600	0	Oscilloscope: No additional data available	-	-

Error code	Error class	Description	Cause	Correctives
1601	0	Oscilloscope: Parameterization incomplete	-	-
1602	0	Oscilloscope: Trigger variable not defined	-	-
1606	0	Logging still active	-	-
1607	0	Logging: No trigger defined	-	-
1608	0	Logging: Invalid trigger option	-	-
1609	0	Logging: No channel selected	-	-
160A	0	Logging: No data available	-	-
160B	0	Parameter cannot be logged	-	-
160C	1	Autotuning: Moment of inertia outside permissible range	The load inertia is too high.	Verify that the system can easily be moved. Verify the load. Use a differently rated drive.
160E	1	Autotuning: Test movement could not be started	-	-
160F	1	Autotuning: Power stage cannot be enabled	Autotuning was not started in the operating state Ready To Switch On.	Start Autotuning when the drive is in the operating state Ready To Switch On.
1610	1	Autotuning: Processing stopped	Autotuning stopped by user command or by detected error (see additional error message in error memory, for example, DC bus undervoltage, limit switches triggered)	Remove the cause of the stop and restart Autotuning.
1611	1	System error detected: Parameter could not be written during Autotuning. Additional information in the error memory indicates the Modbus register address.	-	-
1612	1	System error detected: Parameter could not be read during Autotuning	-	-
1613	1	Autotuning: Maximum permissible movement range exceeded Parameter <i>_SigLatched</i> Bit 2	The movement exceeded the adjusted movement range during Autotuning.	Increase the movement range value or disable movement range monitoring by setting AT_DIS = 0.
1614	0	Autotuning: Already active	Autotuning has been started twice simultaneously or an Autotuning parameter is modified during Autotuning (parameter AT_dis and AT_dir).	Wait for Autotuning to finish before restarting Autotuning.
1615	0	Autotuning: This parameter cannot be changed while Autotuning is active	Parameter AT_gain or AT_J are written during Autotuning.	Wait for Autotuning to finish before changing the parameter.
1617	1	Autotuning: Friction torque or load torque too great	The current limit has been reached (parameter CTRL_I_max).	Verify that the system can easily be moved. Verify the load. Use a differently rated drive.
1618	1	Autotuning: Optimization aborted	The internal Autotuning sequence has not been finished, there may have been a following error.	See the additional information provided in the error memory.
1619	0	Autotuning: Velocity jump in parameter AT_n_ref is not sufficient	Parameter AT_n_ref < 2 * AT_n_tolerance. The drive only checks this for the first velocity jump.	Modify the parameter AT_n_ref or AT_n_tolerance to meet the required condition.

Error code	Error class	Description	Cause	Correctives
1620	1	Autotuning: Load torque too high	Product rating is not suitable for the machine load. Detected machine inertia is too high compared to the inertia of the motor.	Reduce load, verify rating.
1621	1	System error detected: Calculation error	-	-
1622	0	Autotuning: Not possible to perform Autotuning	Autotuning can only be performed if no operating mode is active.	Terminate the active operating mode or disable the power stage.
1623	1	Autotuning: HALT request has stopped the autotuning process	Autotuning can only be performed if no operating mode is active.	Terminate the active operating mode or disable the power stage.
1A00	0	System error detected: FIFO memory overflow	-	-
1A01	3	Motor has been changed (different type of motor) Parameter <i>_SigLatched</i> Bit 16	Detected motor type is different from previously detected motor.	Confirm the change.
1A03	4	System error detected: Hardware and firmware do not match	-	-
1B00	3	System error detected: Incorrect parameters for motor and power stage Parameter <i>_SigLatched</i> Bit 30	Incorrect manufacturer parameter value (data) nonvolatile memory of device.	Replace device.
1B02	3	Target value too high. Parameter <i>_SigLatched</i> Bit 30	-	-
1B04	2	Product of encoder simulation resolution and the maximum velocity is too high Parameter <i>_SigLatched</i> Bit 30	Value in parameter CTRL_v_max or resolution or the encoder simulation ESIM_scale are too high.	Reduce the resolution of the encoder simulation or the maximum velocity in parameter CTRL_v_max.
1B05	2	Error detected during parameter switching Parameter <i>_SigLatched</i> Bit 30	-	-
1B0C	3	Motor velocity too high.	-	-
1B0D	3	Velocity value determined by velocity observer is incorrect	Incorrect system inertia for velocity observer calculations. Incorrect velocity observer dynamics. System inertia changes during operation. In this case, operation with velocity observer is not possible and the velocity observer must be deactivated.	Change the velocity observer dynamics via the parameter CTRL_SpdObsDyn. Change the system inertia used for velocity observer calculations via the parameter CTRL_SpdObsInert. If the detected error persists, deactivate the velocity observer.
1B0F	3	Velocity deviation too high	-	-
2300	3	Power stage overcurrent Parameter <i>_SigLatched</i> Bit 27	Motor short circuit and disabling of the power stage. Motor phases are inverted.	Verify the motor power connection.
2301	3	Braking resistor overcurrent Parameter <i>_SigLatched</i> Bit 27	Braking resistor short circuit.	If you use the internal braking resistor, contact your Schneider Electric service representative. If you use an external braking resistor, verify correct wiring and rating of the braking resistor.
3100	par.	Missing mains supply, undervoltage mains supply or overvoltage mains supply Parameter <i>_SigLatched</i> Bit 15	Missing phase(s) for more than 50 ms. Mains voltage is out of range. Mains frequency is out of range.	Verify that the values of the mains power supply network comply with the technical data.

Error code	Error class	Description	Cause	Correctives
3200	3	DC bus overvoltage Parameter <i>_SigLatched</i> Bit 14	Excessive regeneration during deceleration.	Verify correct deceleration ramp, rating of drive and braking resistor.
3201	3	DC bus undervoltage (shutdown threshold) Parameter <i>_SigLatched</i> Bit 13	Power supply outage, insufficient power supply.	Verify mains supply.
3202	2	DC bus undervoltage (Quick Stop threshold) Parameter <i>_SigLatched</i> Bit 13	Power supply outage, insufficient power supply.	Verify mains supply.
3206	0	Undervoltage DC bus, missing mains supply, undervoltage mains supply or overvoltage mains supply Parameter <i>_WarnLatched</i> Bit 13	Missing phase(s) for more than 50 ms. Mains voltage is out of range. Mains frequency is out of range. Mains voltage and setting of parameter <i>MON_MainsVolt</i> do not match (for example, mains voltage is 230 V and <i>MON_MainsVolt</i> is set to 115 V).	Verify that the values of the mains power supply network comply with the technical data. Verify the settings of the parameter for reduced mains voltage.
3300	0	The winding voltage of the motor is lower than the nominal supply voltage of the drive	If the winding voltage of the motor is lower than the nominal supply voltage of the drive, this may result in motor overtemperature due to high current ripple.	Verify the motor temperature. In the case of overtemperature, use a motor with a higher winding voltage or use a drive with a lower nominal supply voltage.
4100	3	Power stage overtemperature Parameter <i>_SigLatched</i> Bit 18	Excessively high ambient temperature due to, for example, dust.	Improve heat dissipation. If a fan is installed, verify correct operation of the fan.
4101	0	Power stage overtemperature Parameter <i>_WarnLatched</i> Bit 18	Excessively high ambient temperature due to, for example, dust.	Improve heat dissipation. If a fan is installed, verify correct operation of the fan.
4102	0	Power stage overload (I2t) Parameter <i>_WarnLatched</i> Bit 30	The current has exceeded the nominal value for an extended period of time.	Verify rating, reduce cycle time.
4200	3	Device overtemperature Parameter <i>_SigLatched</i> Bit 18	Excessively high ambient temperature due to, for example, dust.	Improve heat dissipation. If a fan is installed, verify correct operation of the fan.
4300	2	Motor overtemperature Parameter <i>_SigLatched</i> Bit 17	Ambient temperature is too high. Duty cycle is too high. Motor not properly mounted (thermal isolation). Motor overload.	Verify motor installation: The heat must be dissipated via the mounting surface. Reduce ambient temperature. Provide ventilation.
4301	0	Motor overtemperature Parameter <i>_WarnLatched</i> Bit 17	Ambient temperature is too high. Duty cycle is too high. Motor not properly mounted (thermal isolation). Motor overload.	Verify motor installation: The heat must be dissipated via the mounting surface. Reduce ambient temperature. Provide ventilation.
4302	0	Motor overload (I2t) Parameter <i>_WarnLatched</i> Bit 31	The current has exceeded the nominal value for an extended period of time.	Verify that the system can easily be moved. Verify the load. Use a differently sized motor, if necessary.
4303	0	No motor temperature monitoring	The temperature parameters (in electronic nameplate of motor, nonvolatile memory of encoder) are unavailable or invalid; parameter <i>A12</i> is equal to 0.	Contact your Schneider Electric service representative. Replace motor.

Error code	Error class	Description	Cause	Correctives
4304	0	The encoder does not support motor temperature monitoring.	-	-
4402	0	Braking resistor overload (I _{2t} > 75%) Parameter <i>_WarnLatched</i> Bit 29	Regeneration energy too high. External loads too high. Motor velocity too high. Deceleration too fast. Insufficient braking resistor.	Reduce load, velocity, deceleration. Verify correct braking resistor rating.
4403	par.	Braking resistor overload (I _{2t} > 100%)	Regeneration energy too high. External loads too high. Motor velocity too high. Deceleration too fast. Insufficient braking resistor.	Reduce load, velocity, deceleration. Verify correct braking resistor rating.
4404	0	Overload of transistor for braking resistor Parameter <i>_WarnLatched</i> Bit 28	Regeneration energy too high. External loads too high. Deceleration too fast.	Reduce load and/or deceleration.
5101	0	Modbus power supply missing	-	-
5102	4	Motor encoder supply voltage Parameter <i>_SigLatched</i> Bit 16	Encoder power supply is not within permissible range of 8 V to 12 V.	Replace the device. Contact your Schneider Electric service representative.
5200	4	Error detected at connection to motor encoder Parameter <i>_SigLatched</i> Bit 16	Encoder not properly connected, EMI	-
5201	4	Error detected in motor encoder communication Parameter <i>_SigLatched</i> Bit 16	Encoder not properly connected, EMI	-
5202	4	Motor encoder is not supported Parameter <i>_SigLatched</i> Bit 16	Incompatible encoder connected.	-
5203	4	Error detected in connection motor encoder Parameter <i>_SigLatched</i> Bit 16	Encoder not properly connected	-
5204	3	Connection to motor encoder lost Parameter <i>_SigLatched</i> Bit 16	Encoder not properly connected	-
5206	0	Communication error detected in encoder Parameter <i>_WarnLatched</i> Bit 16	Communication channel to encoder is subject to interference.	Verify EMC measures.
5207	1	Function is not supported	The hardware revision does not support the function.	-
5302	4	The motor requires a PWM frequency (16kHz) which the power stage does not support.	The motor only works with a PWM frequency of 16 kHz (motor nameplate entry). However, the power stage does not support this PWM frequency.	Use a motor that works with a PWM frequency of 8 kHz. Contact your Schneider Electric service representative.
5430	4	System error detected: Nonvolatile memory read error Parameter <i>_SigLatched</i> Bit 29	-	-
5431	3	System error: Nonvolatile memory write error Parameter <i>_SigLatched</i> Bit 29	-	-

Error code	Error class	Description	Cause	Correctives
5432	3	System error: Nonvolatile memory state machine Parameter <i>_SigLatched</i> Bit 29	-	-
5433	3	System error: Nonvolatile memory address error Parameter <i>_SigLatched</i> Bit 29	-	-
5434	3	System error: Nonvolatile memory incorrect data length Parameter <i>_SigLatched</i> Bit 29	-	-
5435	4	System error: Nonvolatile memory not formatted Parameter <i>_SigLatched</i> Bit 29	-	-
5436	4	System error: Nonvolatile memory incompatible structure Parameter <i>_SigLatched</i> Bit 29	-	-
5437	4	System error detected: Nonvolatile memory checksum error (manufacturer data) Parameter <i>_SigLatched</i> Bit 29	-	-
5438	3	System error detected: Nonvolatile memory checksum error (user parameters) Parameter <i>_SigLatched</i> Bit 29	-	-
5439	3	System error detected: Nonvolatile memory checksum error (fieldbus parameters) Parameter <i>_SigLatched</i> Bit 29	-	-
543B	4	System error detected: No valid manufacturer data Parameter <i>_SigLatched</i> Bit 29	-	-
543E	3	System error detected: Nonvolatile memory checksum error (NoInit parameter) Parameter <i>_SigLatched</i> Bit 29	-	-
543F	3	System error detected: Nonvolatile memory checksum error (motor parameters) Parameter <i>_SigLatched</i> Bit 29	-	-
5441	4	System error detected: Nonvolatile memory checksum error (global control loop parameter set) Parameter <i>_SigLatched</i> Bit 29	-	-
5442	4	System error detected: Nonvolatile memory checksum error (control loop parameter set 1) Parameter <i>_SigLatched</i> Bit 29	-	-
5443	4	System error detected: Nonvolatile memory checksum error (control loop parameter set 2) Parameter <i>_SigLatched</i> Bit 29	-	-
5444	4	System error detected: Nonvolatile memory checksum error (NoReset parameter) Parameter <i>_SigLatched</i> Bit 29	-	-

Error code	Error class	Description	Cause	Correctives
5445	4	System error detected: Nonvolatile memory checksum error (hardware information) Parameter <i>_SigLatched</i> Bit 29	-	-
5446	4	System error detected: Nonvolatile memory checksum error (for power outage data) Parameter <i>_SigLatched</i> Bit 29	Internal nonvolatile memory not operative.	Restart the drive. If the detected error persists, contact your Schneider Electric service representative.
5448	2	System error detected: Communication with memory card Parameter <i>_SigLatched</i> Bit 20	-	-
5449	2	System error detected: Memory card bus is busy Parameter <i>_SigLatched</i> Bit 20	-	-
544A	4	System error detected: Nonvolatile memory checksum error (administration data) Parameter <i>_SigLatched</i> Bit 29	-	-
544C	4	System error detected: Nonvolatile memory is write-protected Parameter <i>_SigLatched</i> Bit 29	-	-
544D	2	System error detected: Memory card Parameter <i>_SigLatched</i> Bit 20	The last saving procedure may not have been successful; the memory card may be inoperative.	Retry saving the data. Replace the memory card.
544E	2	System error detected: Memory card Parameter <i>_SigLatched</i> Bit 20	The last saving procedure may not have been successful; the memory card may be inoperative.	Retry saving the data. Replace the memory card.
544F	2	System error detected: Memory card Parameter <i>_SigLatched</i> Bit 20	The last saving procedure may not have been successful; the memory card may be inoperative.	Retry saving the data. Replace the memory card.
5451	0	System error detected: No memory card available Parameter <i>_WarnLatched</i> Bit 20	-	-
5452	2	System error detected: Data on memory card and device do not match Parameter <i>_SigLatched</i> Bit 20	Different type of device. Different type of power stage. Data on memory card does not match firmware version of device.	-
5453	2	System error detected: Incompatible data on the memory card Parameter <i>_SigLatched</i> Bit 20	-	-
5454	2	System error detected: Capacity of detected memory card insufficient Parameter <i>_SigLatched</i> Bit 20	-	-
5455	2	System error detected: Memory card not formatted properly Parameter <i>_SigLatched</i> Bit 20	-	Format memory card or copy data from drive to memory card.
5456	1	System error detected: Memory card is write-protected Parameter <i>_SigLatched</i> Bit 20	The memory card has been write-protected.	Remove memory card or disable write protection.
5457	2	System error detected: Incompatible memory card Parameter <i>_SigLatched</i> Bit 20	Memory card capacity is insufficient.	Replace memory card

Error code	Error class	Description	Cause	Correctives
5462	0	Memory card implicitly written by the device Parameter <i>_WarnLatched</i> Bit 20	The content of the memory card and the content of the nonvolatile memory are not identical.	-
546C	0	Nonvolatile memory file not available	-	-
5600	3	Motor connection phase error detected Parameter <i>_SigLatched</i> Bit 26	Missing motor phase.	-
5603	3	Commutation error detected. Additional information in the error memory indicates Internal_ DeltaQuep. Parameter <i>_SigLatched</i> Bit 26	Incorrect wiring of motor cable. Encoder signals are lost or subject to interference. The load torque is greater than the motor torque. The encoder nonvolatile memory contains incorrect data (encoder phase offset is incorrect). Motor is not adjusted.	Verify motor phases, verify encoder wiring. Improve EMC, verify grounding and shield connection. Use a differently sized motor that can withstand the load torque. Verify the motor data. Contact your Schneider Electric service representative.
6102	4	System error detected: Internal software error Parameter <i>_SigLatched</i> Bit 30	-	-
6103	4	System error detected: System stack overflow Parameter <i>_SigLatched</i> Bit 31	-	-
6104	0	System error detected: Division by zero (internal)	-	-
6105	0	System error detected: Overflow during 32 bit calculation (internal)	-	-
6106	4	System error detected: Size of data interface does not match Parameter <i>_SigLatched</i> Bit 30	-	-
6107	0	Parameter outside of value range (calculation error detected)	-	-
6108	0	Function not available	-	-
6109	0	System error detected: Internal range exceeded	-	-
610A	2	System error detected: Calculated value cannot be represented as a 32 bit value	-	-
610D	0	Error detected in selection parameter	Incorrect parameter value selected.	Verify the value to be written.
610E	4	System error detected: 24 VDC below undervoltage threshold for shutdown	-	-
610F	4	System error detected: Internal timer basis missing (Timer0) Parameter <i>_SigLatched</i> Bit 30	-	-
6111	2	System error detected: Memory area locked Parameter <i>_SigLatched</i> Bit 30	-	-
6112	2	System error detected: Out of memory Parameter <i>_SigLatched</i> Bit 30	-	-
6113	1	System error detected: Calculated value cannot be represented as a 16 bit value	-	-

Error code	Error class	Description	Cause	Correctives
6114	4	System error detected: Impermissible function call from interrupt service routine	Incorrect programming	-
6117	0	Holding brake cannot be released manually.	The holding brake cannot be released manually because it is still applied manually.	First, switch from applying the holding brake manually to Automatic, then to releasing the holding brake manually.
7100	4	System error detected: Invalid power stage data Parameter <i>_SigLatched</i> Bit 30	Error detected in power stage data stored in device (incorrect CRC), error detected in internal memory data.	Contact your Schneider Electric service representative or replace the device.
7110	2	System error detected: Internal braking resistor	Internal braking resistor is inoperative or not connected.	Contact your Schneider Electric service representative.
7111	0	Parameter cannot be changed because the external braking resistor is active.	An attempt is made to change one of the parameters RESExt_ton, RESExt_P or RESExt_R even though the external braking resistor is active.	Verify that the external braking resistor is not active if one of the parameters RESExt_ton, RESExt_P or RESExt_R has to be changed.
7112	2	No external braking resistor connected	External braking resistor activated (Parameter RESint_ext), but no external resistor is detected.	Verify wiring of the external braking resistor. Verify correct resistance.
7120	4	Invalid motor data Parameter <i>_SigLatched</i> Bit 16	Motor data is incorrect (incorrect CRC).	Contact your Schneider Electric service representative or replace the motor.
7121	2	System error detected: Error in motor encoder communication Parameter <i>_SigLatched</i> Bit 16	EMI, detailed information can be found in the error memory that contains the error code of the encoder.	Contact your Schneider Electric service representative.
7122	4	Invalid motor data Parameter <i>_SigLatched</i> Bit 30	Error detected in motor data stored in motor encoder, error detected in internal memory data.	Contact your Schneider Electric service representative or replace the motor.
7124	4	System error detected: Motor encoder inoperative Parameter <i>_SigLatched</i> Bit 16	-	Contact your Schneider Electric service representative or replace the motor.
7125	4	System error detected: Length specification for user data too great Parameter <i>_SigLatched</i> Bit 16	-	-
7129	0	System error detected: Motor encoder Parameter <i>_WarnLatched</i> Bit 16	-	-
712C	0	System error detected: Communication with encoder not possible Parameter <i>_WarnLatched</i> Bit 16	-	-
712D	4	Electronic motor nameplate not found Parameter <i>_SigLatched</i> Bit 16	Incorrect motor data (incorrect CRC). Motor without electronic motor nameplate (for example, SER motor)	Contact your Schneider Electric service representative or replace the motor.
712F	0	No data segment of the electronic motor nameplate	-	-
7132	0	System error detected: Motor configuration cannot be written	-	-
7134	4	Incomplete motor configuration Parameter <i>_SigLatched</i> Bit 16	-	-
7135	4	Format is not supported Parameter <i>_SigLatched</i> Bit 16	-	-
7136	4	Incorrect encoder type selected with parameter MotEncType Parameter <i>_SigLatched</i> Bit 16	-	-

Error code	Error class	Description	Cause	Correctives
7137	4	Error detected during the internal conversion of the motor configuration Parameter <i>_SigLatched</i> Bit 16	-	-
7138	4	Parameter of the motor configuration out of permissible range Parameter <i>_SigLatched</i> Bit 16	-	-
7139	0	Encoder offset: Data segment in encoder is incorrect.	-	-
713A	3	Adjustment value of the encoder of the third party motor has not yet been determined. Parameter <i>_SigLatched</i> Bit 16	-	-
7200	4	System error detected: Calibration analog/digital converter during manufacturing / incorrect BLE file Parameter <i>_SigLatched</i> Bit 30	-	-
7320	4	System error detected: Invalid encoder parameter Parameter <i>_SigLatched</i> Bit 16	Communication channel (Hiperface) to encoder is subject to interference, motor encoder has not been factory-parameterized.	Contact your Schneider Electric service representative.
7321	3	Timeout reading the absolute position from the encoder Parameter <i>_SigLatched</i> Bit 16	Communication channel (Hiperface) to encoder is subject to interference or motor encoder is inoperative.	Verify EMC measures.
7327	0	Error bit set in Hiperface answer Parameter <i>_WarnLatched</i> Bit 16	EMI.	Verify wiring (shield).
7328	4	Motor encoder: Position evaluation error detected Parameter <i>_SigLatched</i> Bit 16	Encoder has detected incorrect position evaluation.	Contact your Schneider Electric service representative or replace the motor.
7329	0	Motor encoder Warn signal Parameter <i>_WarnLatched</i> Bit 16	EMI.	Contact your Schneider Electric service representative or replace the motor.
7330	4	System error detected: Motor encoder (Hiperface) Parameter <i>_SigLatched</i> Bit 16	-	Verify EMC measures. Contact your Schneider Electric service representative.
7331	4	System error detected: Motor encoder initialization Parameter <i>_SigLatched</i> Bit 30	-	Verify EMC measures. Contact your Schneider Electric service representative.
7335	0	Communication with motor encoder active Parameter <i>_WarnLatched</i> Bit 16	Command is being processed or communication may be disturbed (EMI).	Verify EMC measures. Contact your Schneider Electric service representative.
733F	4	Amplitude of encoder analog signals too low Parameter <i>_SigLatched</i> Bit 16	Incorrect encoder wiring. Encoder not connected. Encoder signals subject to EMI (shield connection, cabling, etc.).	Verify EMC measures. Contact your Schneider Electric service representative.
7340	3	Reading of absolute position aborted Parameter <i>_SigLatched</i> Bit 16	Communication channel (Hiperface) to encoder is subject to interference. Encoder (in motor) is inoperative.	Verify EMC measures. Contact your Schneider Electric service representative.

Error code	Error class	Description	Cause	Correctives
7341	0	Encoder overtemperature Parameter <i>_WarnLatched</i> Bit 16	The maximum permissible duty cycle is exceeded. The motor was not mounted properly, for example, it is thermally isolated. The motor is blocked so that more current is used than under normal conditions. The ambient temperature is too high.	Reduce the duty cycle, for example, reduce acceleration. Supply additional cooling, for example, use a fan. Mount the motor in such a way as to increase thermal conductivity. Use a differently rated drive or motor. Replace the motor.
7342	2	Encoder overtemperature Parameter <i>_SigLatched</i> Bit 16	The maximum permissible duty cycle is exceeded. The motor was not mounted properly, for example, it is thermally isolated. The motor is blocked so that more current is used than under normal conditions. The ambient temperature is too high.	Reduce the duty cycle, for example, reduce acceleration. Supply additional cooling, for example, use a fan. Mount the motor in such a way as to increase thermal conductivity. Use a differently rated drive or motor. Replace the motor.
7343	0	Absolute position is different from incremental position Parameter <i>_WarnLatched</i> Bit 16	Encoder is subject to EMI. Motor encoder is inoperative.	Verify EMC measures. Contact your Schneider Electric service representative.
7344	3	Absolute position is different from incremental position Parameter <i>_SigLatched</i> Bit 16	Encoder is subject to EMI. Motor encoder is inoperative.	Verify EMC measures. Contact your Schneider Electric service representative.
7345	0	Amplitude of analog signals too high, limit of AD conversion exceeded	Encoder signals subject to EMI (shield connection, wiring, etc.). Encoder inoperative.	Verify EMC measures. Contact your Schneider Electric service representative.
7346	4	System error detected: Encoder not ready Parameter <i>_SigLatched</i> Bit 16	-	Verify EMC measures. Contact your Schneider Electric service representative.
7347	0	System error detected: Position initialization not possible	Analog and digital encoder signals subject to massive interference.	Verify EMC measures. Contact your Schneider Electric service representative.
7348	3	Timeout reading encoder temperature Parameter <i>_SigLatched</i> Bit 16	Encoder without temperature sensor, incorrect encoder connection.	Verify EMC measures. Contact your Schneider Electric service representative.
7349	0	Discrepancy between absolute and analog encoder phases	Analog encoder signals are subject to interference. Encoder inoperative.	Verify EMC measures. Contact your Schneider Electric service representative.
734A	3	Amplitude of analog signals from encoder too high, signals are clipped Parameter <i>_SigLatched</i> Bit 16	Incorrect encoder wiring. Encoder hardware interface inoperative.	-
734B	0	Signal position evaluation of analog encoder inoperative Parameter <i>_WarnLatched</i> Bit 16	Incorrect encoder wiring. Encoder hardware interface inoperative.	-
734C	par.	Error detected with quasi absolute position Parameter <i>_SigLatched</i> Bit 16	The motor shaft may have been moved while the drive was powered down. A quasi absolute position has been detected that is not within the permissible motor shaft deviation range.	If the quasi absolute function is active, only power down the drive if the motor is at a standstill and do not move the motor shaft when the drive is off.
734D	0	Index pulse is not available for the encoder Parameter <i>_WarnLatched</i> Bit 16	-	-

Error code	Error class	Description	Cause	Correctives
734E	4	Error in analog signals from encoder detected. Additional information in the error memory indicates Internal_DeltaQuep. Parameter <i>_SigLatched</i> Bit 16	Encoder cable not properly connected. Encoder signals subject to EMI (shield connection, wiring, etc.). Mechanical issue.	Verify EMC measures. Contact your Schneider Electric service representative.
7500	0	RS485/Modbus: Overrun error detected Parameter <i>_WarnLatched</i> Bit 5	EMI; incorrect cabling.	Verify cables.
7501	0	RS485/Modbus: Framing error detected Parameter <i>_WarnLatched</i> Bit 5	EMI; incorrect cabling.	Verify cables.
7502	0	RS485/Modbus: Parity error detected Parameter <i>_WarnLatched</i> Bit 5	EMI; incorrect cabling.	Verify cables.
7503	0	RS485/Modbus: Receive error detected Parameter <i>_WarnLatched</i> Bit 5	EMI; incorrect cabling.	Verify cables.
7623	0	Absolute encoder signal is not available Parameter <i>_WarnLatched</i> Bit 22	There is no encoder available at the input specified via the parameter ENC_abs_source.	Verify wiring, verify encoder. Change the value of the parameter ENC_abs_source.
7625	0	Not possible to set the absolute position for encoder 1. Parameter <i>_WarnLatched</i> Bit 22	There is no encoder connected to the input for encoder 1.	Connect an encoder to the input for encoder 1 before trying to set the absolute position directly via ENC1_abs_pos.
7701	4	System error detected: Timeout during connection to power stage Parameter <i>_SigLatched</i> Bit 31	-	Contact your Schneider Electric service representative.
7702	4	System error detected: Invalid data received from power stage Parameter <i>_SigLatched</i> Bit 31	-	Contact your Schneider Electric service representative.
7703	4	System error detected: Data exchange with power stage lost Parameter <i>_SigLatched</i> Bit 31	-	Contact your Schneider Electric service representative.
7704	4	System error detected: Exchange of identification data from power stage not successful Parameter <i>_SigLatched</i> Bit 31	-	Contact your Schneider Electric service representative.
7705	4	System error detected: Checksum identification data from power stage incorrect Parameter <i>_SigLatched</i> Bit 31	-	Contact your Schneider Electric service representative.
7706	4	System error detected: No identification frame received from power stage Parameter <i>_SigLatched</i> Bit 31	-	Contact your Schneider Electric service representative.
7707	4	System error detected: Type of power stage and manufacture data do not match	-	Contact your Schneider Electric service representative.
7708	4	PIC voltage supply too low Parameter <i>_SigLatched</i> Bit 31	-	Contact your Schneider Electric service representative.
7709	4	System error detected: Invalid numbers of data received Parameter <i>_SigLatched</i> Bit 31	-	Contact your Schneider Electric service representative.

Error code	Error class	Description	Cause	Correctives
770A	2	PIC received data with incorrect parity Parameter <i>_SigLatched</i> Bit 31	-	Contact your Schneider Electric service representative.
A060	2	Calculated velocity too high for operating mode Electronic Gear Parameter <i>_SigLatched</i> Bit 4	Gear ratio or reference velocity value too high	Reduce the gear ratio or reference velocity.
A061	2	Position change in reference value for operating mode Electronic Gear too high Parameter <i>_SigLatched</i> Bit 4	Position reference change is too high. Error detected at signal input for reference value.	Reduce the resolution of the master. Verify signal input for reference value signal.
A065	0	Parameters cannot be written Parameter <i>_WarnLatched</i> Bit 4	A data set is still active.	Wait until the currently active data set has been terminated.
A068	0	Offset positioning not possible Parameter <i>_WarnLatched</i> Bit 4	Operating mode Electronic Gear inactive or no gear method selected.	Start operating mode Electronic Gear and/or select a gear method.
A069	0	Setting the offset position is not possible Parameter <i>_WarnLatched</i> Bit 4	If offset positioning is active, it is not possible to set the position offset.	Wait until ongoing offset positioning has finished.
A06B	2	Position deviation in operating mode Electronic Gear too high Parameter <i>_SigLatched</i> Bit 4	The position deviation has become excessively high due to a velocity limitation or the release of direction.	Verify the velocity of the external reference values and the velocity limitation. Verify release of direction.
A300	0	Deceleration after HALT request still running	HALT was removed too soon. New command was sent before motor standstill was reached after a HALT request.	Wait for complete stop before removing HALT signal. Wait until motor has come to a complete standstill.
A301	0	Drive in operating state Quick Stop Active	Error with error class 1 detected. Drive stopped with Quick Stop.	-
A302	1	Stop by positive limit switch Parameter <i>_SigLatched</i> Bit 1	The positive limit switch was activated because movement range was exceeded, incorrect operation of limit switch or signal disturbance.	Verify application. Verify limit switch function and connection.
A303	1	Stop by negative limit switch Parameter <i>_SigLatched</i> Bit 1	The negative limit switch was activated because movement range was exceeded, incorrect operation of limit switch or signal disturbance.	Verify application. Verify limit switch function and connection.
A305	0	Power stage cannot be enabled in the operating state Not Ready To Switch On	Fieldbus: An attempt was made to enable the power stage in the operating state Not Ready To Switch On.	Refer to the state diagram.
A306	1	Stop by user-initiated software stop Parameter <i>_SigLatched</i> Bit 3	Drive is in operating state Quick Stop Active due to a software stop request. The activation of a new operating mode is not possible, the error code is sent as the response to the activation command.	Clear break condition with command Fault Reset.
A307	0	Interruption by internal software stop	In the operating modes Homing and Jog, the movement is internally interrupted by an internal software stop. The activation of a new operating mode is not possible, the error code is sent as the response to the activation command.	Perform a Fault Reset.
A308	0	Drive is in operating state Fault or Fault Reaction Active	Error with error class 2 or higher detected.	Verify the error code, remove the cause and perform a Fault Reset.
A309	0	Drive not in operating state Operation Enabled	A command was sent that requires the drive to be in the operating state Operation Enabled (for example, a command to change the operating mode).	Set drive to operating state Operation Enabled and repeat the command.

Error code	Error class	Description	Cause	Correctives
A310	0	Power stage not enabled	Command cannot be used because the power stage is not enabled (operating state Operation Enabled or Quick Stop Active).	Set drive to an operating state in which the power stage is enabled, see state diagram.
A311	0	Operating mode change active	A start request for an operating mode has been received while a change of the operating mode was active.	Wait until the operating mode change has terminated before triggering a start request for another operating mode.
A312	0	Profile generation interrupted	-	-
A313	0	Position overflow, zero point is therefore no longer valid (ref_ok=0)	The movement range limits were exceeded and the zero point is no longer valid. An absolute movement requires a valid zero point.	Define a valid zero point by means of the operating mode Homing.
A314	0	No valid zero point	Command needs a valid zero point (ref_ok=1).	Define a valid zero point by means of the operating mode Homing.
A315	0	Homing active	Command cannot be used while the operating mode Homing is active.	Wait until reference movement is finished.
A316	0	Overflow during calculation of acceleration	-	-
A317	0	Motor is not at a standstill	Command sent which is not permissible when the motor is not at a standstill. For example: - Change of software limit switches - Change of handling of monitoring signals - Setting of reference point - Teach in of data set	Wait until the motor has come to a standstill (x_end = 1).
A318	0	Operating mode active (x_end=0)	Activation of a new operating mode is not possible while another operating mode is still active.	Wait until the command in the operating mode has finished (x_end=1) or terminate active operating mode with HALT command.
A319	1	Manual tuning/Autotuning: Movement out of range Parameter <i>_SigLatched</i> Bit 2	The movement exceeds the parameterized maximum movement range.	Verify permissible movement range value and time interval.
A31A	0	Manual tuning/Autotuning: Amplitude/offset too high	Amplitude plus offset for tuning exceed internal velocity or current limitation.	Choose lower amplitude and offset values.
A31B	0	Halt requested	Command not permissible while Halt is requested.	Clear Halt request and repeat command.
A31C	0	Invalid position setting with software limit switch	Value for negative (positive) software limit switch is greater (less) than value for positive (negative) software limit switch.	Set correct position values.
A31D	0	Velocity range exceeded (parameter CTRL_v_max, M_n_max)	The velocity was set to a value greater than the maximum permissible velocity in parameter CTRL_v_max or M_n_max, whichever is lower.	If the value of parameter M_n_max is greater than the value of parameter CTRL_v_max, increase the value of parameter CTRL_v_max or reduce the velocity value.
A31E	1	Stop by positive software limit switch Parameter <i>_SigLatched</i> Bit 2	Not possible to execute command because positive software limit switch was triggered.	Return to the permissible movement range.
A31F	1	Stop by negative software limit switch Parameter <i>_SigLatched</i> Bit 2	Not possible to execute command because negative software limit switch was triggered.	Return to the permissible movement range.

Error code	Error class	Description	Cause	Correctives
A320	par.	Permissible position deviation exceeded Parameter <i>_SigLatched</i> Bit 8	External load or acceleration are too high.	Reduce external load or acceleration. Use a differently rated drive, if necessary. Error response can be adjusted via parameter <i>ErrorResp_p_dif</i> .
A321	0	Invalid setting for RS422 position interface	-	-
A322	0	Error detected in ramp calculation	-	-
A323	3	System error detected: Processing error detected during generation of profile	-	-
A324	1	Error detected during homing. Additional information in the error memory indicates the detailed error code. Parameter <i>_SigLatched</i> Bit 4	Homing movement was stopped in response to a detected error, the detailed reason is indicated by the additional info in the error memory.	Possible sub-error codes: A325, A326, A327, A328 or A329.
A325	1	Limit switch to be approached not enabled Parameter <i>_SigLatched</i> Bit 4	Homing to positive limit switch or negative limit switch is disabled.	Enable limit switch via 'IOsigLimP' or 'IOsigLimN'.
A326	1	Reference switch not found between positive limit switch and negative limit switch Parameter <i>_SigLatched</i> Bit 4	Reference switch inoperative or not correctly connected.	Verify the function and wiring of the reference switch.
A329	1	More than one signal positive limit switch/negative limit switch/reference switch active Parameter <i>_SigLatched</i> Bit 4	Reference switch or limit switch not connected correctly or supply voltage for switches too low.	Verify the wiring and 24 VDC supply voltage.
A32A	1	Positive limit switch triggered with negative direction of movement Parameter <i>_SigLatched</i> Bit 4	Start reference movement with negative direction (for example, reference movement to negative limit switch) and activate the positive limit switch (switch in opposite direction of movement).	Verify correct connection and function of limit switch. Activate a jog movement with negative direction of movement (target limit switch must be connected to the negative limit switch).
A32B	1	Negative limit switch triggered with positive direction of movement Parameter <i>_SigLatched</i> Bit 4	Start reference movement with positive direction (for example, reference movement to positive limit switch) and activate the negative limit switch (switch in opposite direction of movement).	Verify correct connection and function of limit switch. Activate a jog movement with positive direction of movement (target limit switch must be connected to the positive limit switch).
A32C	1	Reference switch error detected (switch signal briefly enabled or switch overtraveled) Parameter <i>_SigLatched</i> Bit 4	Switch signal disturbance. Motor subjected to vibration or shock when stopped after activation of the switch signal.	Verify supply voltage, cabling and function of switch. Verify motor response after stopping and optimize control loop settings.
A32D	1	Positive limit switch error detected (switch signal briefly enabled or switch overtraveled) Parameter <i>_SigLatched</i> Bit 4	Switch signal disturbance. Motor subjected to vibration or shock when stopped after activation of the switch signal.	Verify supply voltage, cabling and function of switch. Verify motor response after stopping and optimize control loop settings.
A32E	1	Negative limit switch error detected (switch signal briefly enabled or switch overtraveled) Parameter <i>_SigLatched</i> Bit 4	Switch signal disturbance. Motor subjected to vibration or shock when stopped after activation of the switch signal.	Verify supply voltage, cabling and function of switch. Verify motor response after stopping and optimize control loop settings.
A32F	1	Index pulse not found Parameter <i>_SigLatched</i> Bit 4	Index pulse signal not connected or not working properly.	Verify index pulse signal and connection.

Error code	Error class	Description	Cause	Correctives
A330	0	Reference movement to index pulse cannot be reproduced. Index pulse is too close to the switch Parameter <i>_WarnLatched</i> Bit 4	The position difference between the index pulse and the switching point is insufficient.	Increase the distance between the index pulse and the switching point. If possible, the distance between the index pulse and the switching point should be a half motor revolution.
A332	1	Jog error detected. Additional information in the error memory indicates the detailed error code. Parameter <i>_SigLatched</i> Bit 4	Jog movement was stopped in response to a detected error.	For additional info, verify the detailed error code in the error memory.
A333	3	System error detected: Invalid internal selection	-	-
A334	2	Timeout Standstill Window monitoring	Position deviation after movement greater than standstill window. This may have been caused by an external load.	Verify load. Verify settings for standstill window (parameter <i>MON_p_win</i> , <i>MON_p_winTime</i> and <i>MON_p_winTout</i>). Optimize control loop settings.
A336	1	System error detected: Jerk limitation with position offset after end of movement. Additional information in the error memory indicates the offset in Increments.	-	-
A337	0	Operating mode cannot be continued Parameter <i>_WarnLatched</i> Bit 4	Continuation of interrupted movement in operating mode Profile Position is not possible because another operating mode had been active in the meantime. In the operating mode Motion Sequence, continuation is not possible if a motion blend was interrupted.	Restart the operating mode.
A338	0	Operating mode unavailable Parameter <i>_WarnLatched</i> Bit 4	The selected operating mode is not available.	-
A339	0	No processing of motor encoder selected or position capture of motor index pulse active Parameter <i>_WarnLatched</i> Bit 4	-	-
A33A	0	No valid zero point (<i>ref_ok=0</i>) Parameter <i>_WarnLatched</i> Bit 4	No zero point defined by means of operating mode Homing. Zero point no longer valid due to movement beyond permissible movement range. Motor does not have an absolute encoder.	Use operating mode Homing to define a valid zero point. Use a motor with an absolute encoder.
A33C	0	Function not available in this operating mode Parameter <i>_WarnLatched</i> Bit 4	Activation of a function which is not available in the active operating mode. Example: Start of backlash compensation while autotuning/manual tuning is active.	-
A33D	0	Motion blend is already active Parameter <i>_WarnLatched</i> Bit 4	Change of motion blend during the ongoing motion blend (end position of motion blend not yet reached)	Wait for the motion blend to complete before setting the next position.
A33E	0	No movement activated Parameter <i>_WarnLatched</i> Bit 4	Activation of a motion blend without movement.	Start a movement before the motion blend is activated.
A33F	0	Position of motion blend movement not in the range of the ongoing movement Parameter <i>_WarnLatched</i> Bit 4	The position of the motion blend is outside of the movement range.	Verify the position of the motion blend and the movement range.

Error code	Error class	Description	Cause	Correctives
A341	0	Position of motion blend has already been passed Parameter <i>_WarnLatched</i> Bit 4	The movement has passed beyond the position of the motion blend.	-
A342	1	Target velocity was not reached at motion blend position. Parameter <i>_SigLatched</i> Bit 4	The position of the motion blend was overtraveled, the target velocity was not reached.	Reduce the ramp velocity so that the target velocity is reached at the position of the motion blend.
A343	0	Processing only possible with linear ramp Parameter <i>_WarnLatched</i> Bit 4	Motion blend position was set with a non-linear ramp.	Set a linear ramp.
A347	0	Permissible position deviation exceeded Parameter <i>_WarnLatched</i> Bit 8	External load or acceleration are too high.	Reduce external load or acceleration. Threshold value can be adjusted via the parameter <i>MON_p_dif_warn</i> .
A348	1	No analog reference value source selected Parameter <i>_SigLatched</i> Bit 4	No analog reference value selected	Select an analog reference value source.
A349	0	Position setting exceeds system limits	Position scaling of <i>POSscaleDenom</i> and <i>POSscaleNum</i> results in a scaling factor that is too small.	Change <i>POSscaleDenom</i> and <i>POSscaleNum</i> in such a way as to increase the resulting scaling factor.
A34A	0	Velocity setting exceeds system limits	The velocity scaling of ' <i>VELscaleDenom</i> ' and ' <i>VELscaleNum</i> ' results in a scaling factor that is too small. The velocity has been set to a value greater than the maximum possible velocity (the maximum velocity is 13200 RPM).	Change ' <i>VELscaleDenom</i> ' and ' <i>VELscaleNum</i> ' in such a way as to increase the resulting scaling factor.
A34B	0	Ramp setting exceeds system limits	The ramp scaling of ' <i>RAMPscaleDenom</i> ' and ' <i>RAMPscaleNum</i> ' results in a scaling factor that is too small.	Change of ' <i>RAMPscaleDenom</i> ' and ' <i>RAMPscaleNum</i> ' in such a way as to increase the resulting scaling factor.
A34C	0	Resolution of scaling too high (range exceeded)	-	-
A350	1	Change for jerk filter input position too great Parameter <i>_SigLatched</i> Bit 4	Operating mode Electronic Gear with processing method 'Position synchronization with compensation movement' has been activated which resulted in a position change greater than 0.25 revolutions.	Deactivate jerk filter processing for Electronic Gear or use processing method 'Position synchronization without compensation movement'.
A351	1	Function cannot be executed with this position scaling factor Parameter <i>_SigLatched</i> Bit 4	The positions scaling factor is set to a value less than $1\text{rev}/131072\text{usr}_p$, which is less than the internal resolution. In the operating mode Cyclic Synchronous Position, the resolution is not set to $1\text{rev}/131072\text{usr}_p$.	Use a different position scaling factor or deactivate the selected function.
A355	1	Error detected during relative movement after capture. Additional information in the error memory indicates the detailed error code. Parameter <i>_SigLatched</i> Bit 4	Movement was stopped by error.	Verify the error memory.
A356	0	Function Relative Movement After Capture not assigned to a digital input	-	Assign the function Relative Movement After Capture to a digital input.
A357	0	Deceleration still running	Command is not permissible during deceleration.	Wait until motor has come to a complete standstill.
A358	1	Target position overtraveled with function Relative Movement After Capture Parameter <i>_SigLatched</i> Bit 4	Stopping distance too small or velocity too high at the point in time of the capture event.	Reduce the velocity.

Error code	Error class	Description	Cause	Correctives
A359	0	Request cannot be processed since the relative movement after capture is still active	-	-
A35D	par.	Permissible velocity deviation exceeded Parameter <i>_SigLatched</i> Bit 8	Load or acceleration too high.	Reduce load or acceleration.
A35E	0	The selected velocity scaling factor reduces the accuracy of the velocity scaling.	-	Increase or decrease the value of the numerator and/or denominator of the scaling factor. If the condition persists, contact your Schneider Electric service representative.
A35F	0	The selected ramp scaling factor reduces the accuracy of the ramp scaling.	-	Increase or decrease the value of the numerator and/or denominator of the scaling factor. If the condition persists, contact your Schneider Electric service representative.
B100	0	RS485/Modbus: Indeterminable service Parameter <i>_WarnLatched</i> Bit 5	Unsupported Modbus service was received.	Verify application on the Modbus master.
B200	0	RS485/Modbus: Protocol error detected Parameter <i>_WarnLatched</i> Bit 5	Logical protocol error detected: Incorrect length or unsupported subfunction.	Verify application on the Modbus master.
B201	2	RS485/Modbus: Interruption of the connection Parameter <i>_SigLatched</i> Bit 5	Connection monitoring has detected an interruption of the connection.	Verify all connections and cables used for data exchange. Verify that the device is on.
B202	0	RS485/Modbus: Interruption of the connection Parameter <i>_WarnLatched</i> Bit 5	Connection monitoring has detected an interruption of the connection.	Verify all connections and cables used for data exchange. Verify that the device is on.
B203	0	RS485/Modbus: Incorrect number of monitor objects Parameter <i>_WarnLatched</i> Bit 5	-	-

Parameters

Representation of the Parameters

Description

This section provides an overview of the parameters which can be used for operating the drive.

Unsuitable parameter values or unsuitable data may trigger unintended movements, trigger signals, damage parts and disable monitoring functions. Some parameter values or data do not become active until after a restart.

⚠ WARNING
<p>UNINTENDED EQUIPMENT OPERATION</p> <ul style="list-style-type: none"> • Only start the system if there are no persons or obstructions in the zone of operation. • Do not operate the drive system with undetermined parameter values or data. • Never modify a parameter value unless you fully understand the parameter and all effects of the modification. • Restart the drive and verify the saved operational data and/or parameter values after modifications. • Carefully run tests for all operating states and potential error situations when commissioning, upgrading or otherwise modifying the operation of the drive. • Verify the functions after replacing the product and also after making modifications to the parameter values and/or other operational data. <p>Failure to follow these instructions can result in death, serious injury, or equipment damage.</p>

Overview

The way parameters are shown provides information required for unique identification, the default values and the properties of a parameter.

Structure of the parameter representation:

Parameter name	Description	Unit	Data type	Parameter address via fieldbus
HMI menu		Minimum value	R/W	
HMI name		Factory setting	Persistent	
		Maximum value	Expert	
ABCDE CONF → INF - Prn	Short description Selection values 1 / Abc1 / ABC 1: Explanation 1 2 / Abc2 / ABC 2: Explanation 2 Description and details	A _{pk} 0.00 3.00 300.00	UINT32 R/W per. -	Modbus 1234

Field “Parameter Name”

The parameter name uniquely identifies a parameter.

Field “HMI menu” and “HMI name”

HMI menu shows the sequence of menus and commands to access the parameter via the HMI.

Field “Description”

Short description:

The short description contains information on the parameter and a cross reference to the page that describes the use of the parameter.

Selection values:

In the case of parameters which offer a selection of settings, the value to be entered via Modbus, the designation of the value for entry via the commissioning software and the designation of the value for entry via the HMI are specified.

1 = Value for input via Modbus

Abc1 = Designation for entry via the commissioning software

Abc 1 = Designation for entry via the HMI

Description and details:

Provides further information on the parameter.

Field “Unit”

The unit of the value.

Field “Minimum Value”

The minimum value which can be entered.

Field “Factory Settings”

Settings when the product is shipped.

Field “Maximum Value”

The maximum value which can be entered.

Field “Data Type”

If the minimum and the maximum values are not explicitly indicated, the valid range of values is determined by the data type.

Data type	Minumum value	Maximum value
INT8	-128	127
UINT8	0	255
INT16	-32768	32767
UINT16	0	65535
INT32	-2147483648	2147483647
UINT32	0	4294967295

Field “R/W”

Indicates read and/or write values

"R/" values can only be read

"R/W" values can be read and written.

Field "Persistent"

"per." indicates whether the value of the parameter is persistent, i.e. whether it remains in the memory after the device is powered off.

When a value of a persistent parameter is modified via the HMI, the drive stores the value automatically in the persistent memory.

When a value of a persistent parameter is modified via the commissioning software, the user must explicitly store the modified value in the persistent memory.

Field "Parameter Address"

Each parameter has a unique parameter address.

List of Parameters

Parameter name HMI menu HMI name	Description	Unit Minimum value Factory setting Maximum value	Data type R/W Persistent Expert	Parameter address via fieldbus
<i>_AccessInfo</i>	Access channel information. Low byte: Exclusive access Value 0: No Value 1: Yes High byte: Access channel Value 0: Reserved Value 1: I/O Value 2: HMI Value 3: Modbus RS485	- - - -	UINT16 R/- - -	Modbus 280
<i>_AI1_act</i> <i>П о н</i> <i>Р н Р 1</i>	Analog 1: Value of input voltage.	mV -10000 - 10000	INT16 R/- - -	Modbus 2306
<i>_AI2_act</i> <i>П о н</i> <i>Р н Р 2</i>	Analog 2: Value of input voltage.	mV -10000 - 10000	INT16 R/- - -	Modbus 2314
<i>_AT_J</i>	Moment of inertia of the system. Is automatically calculated during Autotuning. In increments of 0.1 kg cm ² .	kg cm ² 0.1 0.1 6553.5	UINT16 R/- per. -	Modbus 12056

Parameter name HMI menu HMI name	Description	Unit Minimum value Factory setting Maximum value	Data type R/W Persistent Expert	Parameter address via fieldbus
<i>_AT_M_friction</i>	Friction torque of the system. Is determined during Autotuning. In increments of 0.01 A_{rms} .	A_{rms} - - -	UINT16 R/- - -	Modbus 12046
<i>_AT_M_load</i>	Constant load torque. Is determined during Autotuning. In increments of 0.01 A_{rms} .	A_{rms} - - -	INT16 R/- - -	Modbus 12048
<i>_AT_progress</i>	Progress of Autotuning.	% 0 0 100	UINT16 R/- - -	Modbus 12054
<i>_AT_state</i>	Autotuning status. Bit assignments: Bits 0 ... 10: Last processing step Bit 13: auto_tune_process Bit 14: auto_tune_end Bit 15: auto_tune_err	- - - -	UINT16 R/- - -	Modbus 12036
<i>_CommutCntAct</i>	Actual value of commutation monitoring counter. Available with firmware version $\geq V01.32$.	- - - -	INT16 R/- - -	Modbus 16324
<i>_Cond_State4</i>	Conditions for transition to operating state Ready To Switch On. Signal state: 0: Condition not met 1: Condition met Bit 0: DC bus or mains voltage Bit 1: Inputs for safety function Bit 2: No configuration download ongoing Bit 3: Velocity greater than limit value Bit 4: Absolute position has been set Bit 5: Holding brake not manually released	- - - -	UINT16 R/- - -	Modbus 7244
<i>_CTRL_ActParSet</i>	Active control loop parameter set. Value 1: Control loop parameter set 1 is active Value 2: Control loop parameter set 2 is active A control loop parameter set is active after the time for the parameter switching (CTRL_ParChgTime) has elapsed.	- - - -	UINT16 R/- - -	Modbus 4398

Parameter name HMI menu HMI name	Description	Unit Minimum value Factory setting Maximum value	Data type R/W Persistent Expert	Parameter address via fieldbus
<i>_CTRL_KPid</i>	Current controller d component P gain. This value is calculated on the basis of the motor parameters. In increments of 0.1 V/A.	V/A 0.5 - 1270.0	UINT16 R/- per. -	Modbus 4354
<i>_CTRL_KPiq</i>	Current controller q component P gain. This value is calculated on the basis of the motor parameters. In increments of 0.1 V/A.	V/A 0.5 - 1270.0	UINT16 R/- per. -	Modbus 4358
<i>_CTRL_TNid</i>	Current controller d component integral action time. This value is calculated on the basis of the motor parameters. In increments of 0.01 ms.	ms 0.13 - 327.67	UINT16 R/- per. -	Modbus 4356
<i>_CTRL_TNiq</i>	Current controller q component integral action time. This value is calculated on the basis of the motor parameters. In increments of 0.01 ms.	ms 0.13 - 327.67	UINT16 R/- per. -	Modbus 4360
<i>_DCOMstatus</i>	DriveCom status word. Bit assignments: Bit 0: Operating state Ready To Switch On Bit 1: Operating state Switched On Bit 2: Operating state Operation Enabled Bit 3: Operating state Fault Bit 4: Voltage Enabled Bit 5: Operating state Quick Stop Bit 6: Operating state Switch On Disabled Bit 7: Error of error class 0 Bit 8: HALT request active Bit 9: Remote Bit 10: Target Reached Bit 11: Internal Limit Active Bit 12: Operating mode-specific Bit 13: x_err Bit 14: x_end Bit 15: ref_ok	- - - - - - - - - - - - - - - - - - - -	UINT16 R/- - -	Modbus 6916
<i>_DEV_T_current</i> <i>Π ο ς</i> <i>Ε δ Ε V</i>	Temperature of device.	°C - - -	INT16 R/- - -	Modbus 7204

Parameter name	Description	Unit	Data type	Parameter address via fieldbus
HMI menu		Minimum value	R/W	
HMI name		Factory setting	Persistent	
		Maximum value	Expert	
<i>_DPL_BitShiftRefA16</i>	Bit shift for RefA16 for Drive Profile Lexium. Velocity scaling may lead to values that cannot be represented as 16 bit values. If RefA16 is used, this parameter indicates the number of bits by which the value is shifted so that transmission is possible. The master must take into account this value prior to transmission and shift the bits to the right accordingly. The number of bits is recalculated each time the power stage is enabled.	- 0 0 12	UINT16 R/- - -	Modbus 6922
<i>_DPL_driveInput</i>	Drive Profile Lexium driveInput.	- - - -	UINT16 R/- - -	Modbus 6992
<i>_DPL_driveStat</i>	Drive Profile Lexium driveStat.	- - - -	UINT16 R/- - -	Modbus 6986
<i>_DPL_mfStat</i>	Drive Profile Lexium mfStat.	- - - -	UINT16 R/- - -	Modbus 6988
<i>_DPL_motionStat</i>	Drive Profile Lexium motionStat.	- - - -	UINT16 R/- - -	Modbus 6990
<i>_ENC_AmplMax</i>	Maximum value of the SinCos amplitude. This value is only available if monitoring of the SinCos amplitude has been activated. Available with firmware version \geq V01.26.	mV - - -	UINT16 R/- - -	Modbus 16320
<i>_ENC_AmplMean</i>	Mean value of the SinCos amplitude. This value is only available if monitoring of the SinCos amplitude has been activated. Available with firmware version \geq V01.26.	mV - - -	UINT16 R/- - -	Modbus 16316
<i>_ENC_AmplMin</i>	Minimum value of the SinCos amplitude. This value is only available if monitoring of the SinCos amplitude has been activated. Available with firmware version \geq V01.26.	mV - - -	UINT16 R/- - -	Modbus 16318
<i>_ENC_AmplVal</i>	Value of the SinCos amplitude. This value is only available if monitoring of the SinCos amplitude has been activated. Available with firmware version \geq V01.26.	mV - - -	UINT16 R/- - -	Modbus 16314

Parameter name HMI menu HMI name	Description	Unit Minimum value Factory setting Maximum value	Data type R/W Persistent Expert	Parameter address via fieldbus
<i>_GEAR_p_diff</i>	Position deviation in operating mode Electronic Gear. Position deviation between reference position and actual position with the methods "Position Synchronization Without Compensation Movement" and "Position Synchronization With Compensation Movement". A position deviation can be caused by a movement in a blocked direction (parameter <i>GEARdir_enabl</i>) or by a velocity limitation (parameter <i>GEARpos_v_max</i>). Available with firmware version $\geq V01.10$.	Inc - - -	INT32 R/- - -	Modbus 7962
<i>_hwVersCPU</i>	Hardware version of control board.	- - - -	UINT16 R/- - -	Modbus 548
<i>_hwVersPS</i>	Hardware version of power stage.	- - - -	UINT16 R/- - -	Modbus 552
<i>_I_act</i> <i>Π α ρ</i> <i>ι Ρ α τ</i>	Total motor current. In increments of $0.01 A_{rms}$.	A_{rms} - - -	INT16 R/- - -	Modbus 7686
<i>_Id_act_rms</i>	Actual motor current (d component, field weakening). In increments of $0.01 A_{rms}$.	A_{rms} - - -	INT16 R/- - -	Modbus 7684
<i>_Id_ref_rms</i>	Reference motor current (d component, field weakening). In increments of $0.01 A_{rms}$.	A_{rms} - - -	INT16 R/- - -	Modbus 7714
<i>_Imax_act</i>	Currently effective current limitation. Value of the currently effective current limitation. This is one of the following values (whichever is lowest): - <i>CTRL_I_max</i> (only during normal operation) - <i>LIM_I_maxQSTP</i> (only during Quick Stop) - <i>LIM_I_maxHalt</i> (only during Halt) - Current limitation via analog input - Current limitation via digital input - <i>_M_I_max</i> (only if motor is connected) - <i>_PS_I_max</i> Limitations caused by I2t monitoring are also taken into account. In increments of $0.01 A_{rms}$.	A_{rms} - - - - - - - - - -	UINT16 R/- - - - - - - - - -	Modbus 7248

Parameter name HMI menu HMI name	Description	Unit Minimum value Factory setting Maximum value	Data type R/W Persistent Expert	Parameter address via fieldbus
<i>_Imax_system</i>	Current limitation of the system. This parameter specifies the maximum system current. This is the lower value of the maximum motor current and the maximum power stage current. If no motor is connected, only the maximum power stage current is taken into account in this parameter. In increments of 0.01 A _{rms} .	A _{rms} - - -	UINT16 R/- - -	Modbus 7246
<i>_InvalidParam</i>	Modbus address of parameter with invalid value. If a configuration error is detected, the Modbus address of the parameter with an invalid value is indicated here.	- - 0 -	UINT16 R/- - -	Modbus 7180
<i>_IO_act</i>	Physical status of the digital inputs and outputs. Low byte: Bit 0: DI0 Bit 1: DI1 Bit 2: DI2 Bit 3: DI3 Bit 4: DI4 Bit 5: DI5 High byte: Bit 8: DQ0 Bit 9: DQ1 Bit 10: DQ2 Bit 11: DQ3 Bit 12: DQ4	- -	UINT16 R/- - - - - - - - - - - - - - - - - - - -	Modbus 2050
<i>_IO_DI_act</i> <i>Ποπ</i> <i>διΠο</i>	Status of digital inputs. Bit assignments: Bit 0: DI0 Bit 1: DI1 Bit 2: DI2 Bit 3: DI3 Bit 4: DI4 Bit 5: DI5	- - - - - -	UINT16 R/- - - - -	Modbus 2078
<i>_IO_DQ_act</i> <i>Ποπ</i> <i>δοΠο</i>	Status of digital outputs. Bit assignments: Bit 0: DQ0 Bit 1: DQ1 Bit 2: DQ2 Bit 3: DQ3 Bit 4: DQ4	- - - - -	UINT16 R/- - - -	Modbus 2080

Parameter name HMI menu HMI name	Description	Unit Minimum value Factory setting Maximum value	Data type R/W Persistent Expert	Parameter address via fieldbus
<i>_IO_STO_act</i> <i>Π ο η</i> <i>5 τ ο</i>	Status of the inputs for the safety-related function STO. Coding of the individual signals: Bit 0: STO_A Bit 1: STO_B	- - - -	UINT16 R/- - -	Modbus 2124
<i>_Iq_act_rms</i> <i>Π ο η</i> <i>q R c t</i>	Actual motor current (q component, generating torque). In increments of 0.01 A _{rms} .	A _{rms} - - -	INT16 R/- - -	Modbus 7682
<i>_Iq_ref_rms</i> <i>Π ο η</i> <i>q r E F</i>	Reference motor current (q component, generating torque). In increments of 0.01 A _{rms} .	A _{rms} - - -	INT16 R/- - -	Modbus 7712
<i>_LastError</i> <i>Π ο η</i> <i>L F L t</i>	Detected error causing a stop (error classes 1 to 4). Error code of the most recent detected error. Consecutive detected errors do not overwrite this error code. Example: If an error response to a detected limit switch error causes overvoltage, this parameter contains the code of the detected limit switch error. Exception: Detected errors of error class 4 overwrite existing entries.	- - - -	UINT16 R/- - -	Modbus 7178
<i>_LastWarning</i> <i>Π ο η</i> <i>L W r η</i>	Code of most recent error of error class 0. If the error is no longer active, the code is stored until the next Fault Reset. Value 0: No error of error class 0	- - - -	UINT16 R/- - -	Modbus 7186
<i>_M_BRK_T_apply</i>	Holding brake application time.	ms - - -	UINT16 R/- - -	Modbus 3394
<i>_M_BRK_T_release</i>	Holding brake release time.	ms - - -	UINT16 R/- - -	Modbus 3396
<i>_M_Enc_Cosine</i>	Voltage of cosine signal of encoder. In increments of 0.001 V. Available with firmware version ≥V01.26.	V - - -	INT16 R/- - -	Modbus 7254
<i>_M_Enc_Sine</i>	Voltage of sine signal of encoder. In increments of 0.001 V. Available with firmware version ≥V01.26.	V - - -	INT16 R/- - -	Modbus 7256

Parameter name HMI menu HMI name	Description	Unit Minimum value Factory setting Maximum value	Data type R/W Persistent Expert	Parameter address via fieldbus
<i>_M_Encoder</i> <i>C o n F → i n F -</i> <i>S E n S</i>	Type of motor encoder. 1 / SinCos With HiFa / S W h r : SinCos with Hiperface 2 / SinCos Without HiFa / S W o h : SinCos without Hiperface 3 / SinCos With Hall / S W h R : SinCos with Hall 4 / SinCos With EnDat / S W E n : SinCos with EnDat 5 / EnDat Without SinCos / E n d R : EnDat without SinCos 6 / Resolver / r E S o : Resolver 7 / Hall / h R L L : Hall (not supported yet) 8 / BISS / b i S S : BISS High byte: Value 0: Rotary encoder Value 1: Linear encoder	- - - -	UINT16 R/- - -	Modbus 3334
<i>_M_HoldingBrake</i>	Holding brake identification. Value 0: Motor without holding brake Value 1: Motor with holding brake	- - - -	UINT16 R/- - -	Modbus 3392
<i>_M_I_0</i>	Continuous stall current of motor. In increments of 0.01 A _{rms} .	A _{rms} - - -	UINT16 R/- - -	Modbus 3366
<i>_M_I_max</i> <i>C o n F → i n F -</i> <i>π , π R</i>	Maximum current of motor. In increments of 0.01 A _{rms} .	A _{rms} - - -	UINT16 R/- - -	Modbus 3340
<i>_M_I_nom</i> <i>C o n F → i n F -</i> <i>π , π o</i>	Nominal current of motor. In increments of 0.01 A _{rms} .	A _{rms} - - -	UINT16 R/- - -	Modbus 3342
<i>_M_I2t</i>	Maximum permissible time for maximum current of motor.	ms - - -	UINT16 R/- - -	Modbus 3362
<i>_M_Jrot</i>	Moment of inertia of motor. Units: Rotary motors: kgcm ² Linear motors: kg In increments of 0.001 motor_f.	motor_f - - -	UINT32 R/- - -	Modbus 3352

Parameter name HMI menu HMI name	Description	Unit Minimum value Factory setting Maximum value	Data type R/W Persistent Expert	Parameter address via fieldbus
<i>_M_kE</i>	Voltage constant kE of motor. Voltage constant in Vrms at 1000 RPM. Units: Rotary motors: Vrms/RPM Linear motors: Vrms/(m/s) In increments of 0.1 motor_u.	motor_u - - -	UINT32 R/- - -	Modbus 3350
<i>_M_L_d</i>	Inductance d component of motor. In increments of 0.01 mH.	mH - - -	UINT16 R/- - -	Modbus 3358
<i>_M_L_q</i>	Inductance q component of motor. In increments of 0.01 mH.	mH - - -	UINT16 R/- - -	Modbus 3356
<i>_M_load</i> <i>Π α η</i> <i>L d F Π</i>	Load of motor.	% - - -	INT16 R/- - -	Modbus 7220
<i>_M_M_0</i>	Continuous stall torque of motor. A value of 100 % in operating mode Profile Torque corresponds to this parameter. Units: Rotary motors: Ncm Linear motors: N	motor_m - - -	UINT16 R/- - -	Modbus 3372
<i>_M_M_max</i>	Maximum torque of motor. In increments of 0.1 Nm.	Nm - - -	UINT16 R/- - -	Modbus 3346
<i>_M_M_nom</i>	Nominal torque/force of motor. Units: Rotary motors: Ncm Linear motors: N	motor_m - - -	UINT16 R/- - -	Modbus 3344
<i>_M_maxoverload</i>	Maximum value of overload of motor. Maximum overload of motor during the last 10 seconds.	% - - -	INT16 R/- - -	Modbus 7222
<i>_M_n_max</i> <i>Γ α η F → ι η F -</i> <i>Π η Π θ</i>	Maximum permissible speed of rotation/velocity of motor. Units: Rotary motors: RPM Linear motors: mm/s	motor_v - - -	UINT16 R/- - -	Modbus 3336

Parameter name HMI menu HMI name	Description	Unit Minimum value Factory setting Maximum value	Data type R/W Persistent Expert	Parameter address via fieldbus
<i>_M_n_nom</i>	Nominal speed of rotation/velocity of motor. Units: Rotary motors: RPM Linear motors: mm/s	motor_v - - -	UINT16 R/- - -	Modbus 3338
<i>_M_overload</i>	Overload of motor (I2t).	% - - -	INT16 R/- - -	Modbus 7218
<i>_M_Polepair</i>	Number of pole pairs of motor.	- - - -	UINT16 R/- - -	Modbus 3368
<i>_M_PolePairPitch</i>	Pole pair pitch of motor. In increments of 0.01 mm. Available with firmware version $\geq V01.03$.	mm - - -	UINT16 R/- - -	Modbus 3398
<i>_M_R_UV</i>	Winding resistance of motor. In increments of 0.01 Ω .	Ω - - -	UINT16 R/- - -	Modbus 3354
<i>_M_T_current</i> <i>Π α η</i> <i>ε Π α ε</i>	Temperature of motor.	$^{\circ}\text{C}$ - - -	INT16 R/- - -	Modbus 7202
<i>_M_T_max</i>	Maximum temperature of motor.	$^{\circ}\text{C}$ - - -	INT16 R/- - -	Modbus 3360
<i>_M_Type</i> <i>Γ α η F → ι η F -</i> <i>Π ε Υ Ρ</i>	Motor type. Value 0: No motor selected Value >0: Connected motor type	- - - -	UINT32 R/- - -	Modbus 3332
<i>_M_U_max</i>	Maximum voltage of motor. In increments of 0.1 V.	V - - -	UINT16 R/- - -	Modbus 3378
<i>_M_U_nom</i>	Nominal voltage of motor. In increments of 0.1 V.	V - - -	UINT16 R/- - -	Modbus 3348

Parameter name HMI menu HMI name	Description	Unit Minimum value Factory setting Maximum value	Data type R/W Persistent Expert	Parameter address via fieldbus
<i>_n_act</i> <i>П о н</i> <i>н Р с t</i>	Actual speed of rotation.	RPM - - -	INT16 R/- - -	Modbus 7696
<i>_n_act_ENC1</i>	Actual speed of rotation of encoder 1. Available with firmware version \geq V01.03.	RPM - - -	INT16 R/- - -	Modbus 7760
<i>_n_ref</i> <i>П о н</i> <i>н r E F</i>	Reference speed of rotation.	RPM - - -	INT16 R/- - -	Modbus 7694
<i>_OpHours</i> <i>П о н</i> <i>о P h</i>	Operating hours counter.	s - - -	UINT32 R/- - -	Modbus 7188
<i>_p_absENC</i> <i>П о н</i> <i>Р Р П u</i>	Absolute position with reference to the encoder range. This value corresponds to the modulo position of the absolute encoder range.	usr_p - - -	UINT32 R/- - -	Modbus 7710
<i>_p_absmodulo</i>	Absolute position with reference to internal resolution in internal units. This value is based on encoder raw position with reference to internal resolution (131072 Inc).	Inc - - -	UINT32 R/- - -	Modbus 7708
<i>_p_act</i>	Actual position.	usr_p - - -	INT32 R/- - -	Modbus 7706
<i>_p_act_ENC1</i>	Actual position of encoder 1. Available with firmware version \geq V01.03.	usr_p - - -	INT32 R/- - -	Modbus 7758
<i>_p_act_ENC1_int</i>	Actual position of encoder 1 in internal units. Available with firmware version \geq V01.03.	Inc - - -	INT32 R/- - -	Modbus 7756
<i>_p_act_int</i>	Actual position in internal units.	Inc - - -	INT32 R/- - -	Modbus 7700

Parameter name HMI menu HMI name	Description	Unit Minimum value Factory setting Maximum value	Data type R/W Persistent Expert	Parameter address via fieldbus
<i>_p_addGEAR</i>	Initial position electronic gear. When Electronic Gear is inactive, the reference position for the position controller can be determined here. This position is set when Electronic Gear is activated with the selection of 'Synchronization with compensation movement'.	Inc - - -	INT32 R/- - -	Modbus 7942
<i>_p_dif</i>	Position deviation including dynamic position deviation. Position deviation is the difference between reference position and actual position. The position deviation consists of the load-dependent position deviation and the dynamic position deviation. The parameter <i>_p_dif_usr</i> allows you to enter the value in user-defined units. In increments of 0.0001 revolution.	revolution -214748.3648 - 214748.3647	INT32 R/- - -	Modbus 7716
<i>_p_dif_load</i>	Load-dependent position deviation between reference and actual positions. The load-dependent position deviation is the difference between the reference position and the actual position caused by the load. This value is used for following error monitoring. The parameter <i>_p_dif_load_usr</i> allows you to enter the value in user-defined units. In increments of 0.0001 revolution.	revolution -214748.3648 - 214748.3647	INT32 R/- - -	Modbus 7736
<i>_p_dif_load_peak</i>	Maximum value of the load-dependent position deviation. This parameter contains the maximum load-dependent position deviation reached so far. A write access resets this value. The parameter <i>_p_dif_load_peak_usr</i> allows you to enter the value in user-defined units. In increments of 0.0001 revolution. Modified settings become active immediately.	revolution 0.0000 - 429496.7295	UINT32 R/W - -	Modbus 7734
<i>_p_dif_load_peak_usr</i>	Maximum value of the load-dependent position deviation. This parameter contains the maximum load-dependent position deviation reached so far. A write access resets this value. Modified settings become active immediately. Available with firmware version \geq V01.05.	usr_p 0 - 2147483647	INT32 R/W - -	Modbus 7722
<i>_p_dif_load_usr</i>	Load-dependent position deviation between reference and actual positions. The load-dependent position deviation is the difference between the reference position and the actual position caused by the load. This value is used for following error monitoring. Available with firmware version \geq V01.05.	usr_p -2147483648 - 2147483647	INT32 R/- - -	Modbus 7724
<i>_p_dif_usr</i>	Position deviation including dynamic position deviation. Position deviation is the difference between reference position and actual position. The position deviation consists of the load-dependent position deviation and the dynamic position deviation. Available with firmware version \geq V01.05.	usr_p -2147483648 - 2147483647	INT32 R/- - -	Modbus 7720

Parameter name HMI menu HMI name	Description	Unit Minimum value Factory setting Maximum value	Data type R/W Persistent Expert	Parameter address via fieldbus
<i>_p_PTI_act</i>	Actual position at PTI interface. Counted position increments at PTI interface.	Inc -2147483648 - 2147483647	INT32 R/- - -	Modbus 2058
<i>_p_ref</i>	Reference position. Value corresponds to the reference position of the position controller.	usr_p - - -	INT32 R/- - -	Modbus 7704
<i>_p_ref_int</i>	Reference position in internal units. Value corresponds to the reference position of the position controller.	Inc - - -	INT32 R/- - -	Modbus 7698
<i>_PAR_ScalingError</i>	Additional information on error detected during recalculation. Coding: Bits 0 ... 15: Address of the parameter that caused the error Bits 16 ... 31: Reserved Available with firmware version \geq V01.05.	- - - -	UINT32 R/- - -	Modbus 1068
<i>_PAR_ScalingState</i>	Status of recalculation of the parameters with user-defined units. 0 / Recalculation Active: Recalculation active 1 / Reserved (1): Reserved 2 / Recalculation Finished - No Error: Recalculation finished, no error 3 / Error During Recalculation: Error during recalculation 4 / Initialization Successful: Initialization successful 5 / Reserved (5): Reserved 6 / Reserved (6): Reserved 7 / Reserved (7): Reserved Status of recalculation of the parameters with user-defined units which are recalculated with a changed scaling factor. Available with firmware version \geq V01.05.	- 0 2 7	UINT16 R/- - -	Modbus 1066
<i>_Power_mean</i>	Mean output power.	W - - -	UINT16 R/- - -	Modbus 7196
<i>_pref_acc</i>	Acceleration of reference value for acceleration feed-forward control. Sign according to the changed velocity value: Increased velocity: Positive sign Reduced velocity: Negative sign	usr_a - - -	INT32 R/- - -	Modbus 7954

Parameter name HMI menu HMI name	Description	Unit Minimum value Factory setting Maximum value	Data type R/W Persistent Expert	Parameter address via fieldbus
<i>_pref_v</i>	Velocity of reference value for velocity feed-forward control.	usr_v - - -	INT32 R/- - -	Modbus 7950
<i>_prgNoDEV</i> <i>C o n F → i n F -</i> <i>P r n</i>	Firmware number of device. Example: PR0912.00 The value is provided as a decimal value: 91200	- - - -	UINT32 R/- - -	Modbus 258
<i>_prgRevDEV</i> <i>C o n F → i n F -</i> <i>P r r</i>	Firmware revision of device. The version format is XX.YY.ZZ. Part XX.YY is contained in parameter <i>_prgVerDEV</i> . Part ZZ is used for quality evolution and contained in this parameter. Example: V01.23.45 The value is provided as a decimal value: 45	- - - -	UINT16 R/- - -	Modbus 264
<i>_prgVerDEV</i> <i>C o n F → i n F -</i> <i>P r v</i>	Firmware version of device. The version format is XX.YY.ZZ. Part XX.YY is contained in this parameter. Part ZZ is contained in parameter <i>_prgRevDEV</i> . Example: V01.23.45 The value is provided as a decimal value: 123	- - - -	UINT16 R/- - -	Modbus 260
<i>_PS_I_max</i> <i>C o n F → i n F -</i> <i>P , n A</i>	Maximum current of power stage. In increments of 0.01 A _{rms} .	A _{rms} - - -	UINT16 R/- per. -	Modbus 4100
<i>_PS_I_nom</i> <i>C o n F → i n F -</i> <i>P , n o</i>	Nominal current of power stage. In increments of 0.01 A _{rms} .	A _{rms} - - -	UINT16 R/- per. -	Modbus 4098
<i>_PS_load</i> <i>n o n</i> <i>L d F P</i>	Load of power stage.	% - - -	INT16 R/- - -	Modbus 7214
<i>_PS_maxoverload</i>	Maximum value of overload of power stage. Maximum overload of power stage during the last 10 seconds.	% - - -	INT16 R/- - -	Modbus 7216
<i>_PS_overload</i>	Overload of power stage.	% - - -	INT16 R/- - -	Modbus 7240

Parameter name HMI menu HMI name	Description	Unit Minimum value Factory setting Maximum value	Data type R/W Persistent Expert	Parameter address via fieldbus
<i>_PS_overload_cte</i>	Overload of power stage (chip temperature).	% - - -	INT16 R/- - -	Modbus 7236
<i>_PS_overload_I2t</i>	Overload of power stage (I2t).	% - - -	INT16 R/- - -	Modbus 7212
<i>_PS_overload_psq</i>	Overload of power stage (power squared).	% - - -	INT16 R/- - -	Modbus 7238
<i>_PS_T_current</i> <i>Π α η</i> <i>ε P 5</i>	Temperature of power stage.	°C - - -	INT16 R/- - -	Modbus 7200
<i>_PS_T_max</i>	Maximum temperature of power stage.	°C - - -	INT16 R/- per. -	Modbus 4110
<i>_PS_T_warn</i>	Advisory temperature limit of power stage (error class 0).	°C - - -	INT16 R/- per. -	Modbus 4108
<i>_PS_U_maxDC</i>	Maximum permissible DC bus voltage. In increments of 0.1 V.	V - - -	UINT16 R/- per. -	Modbus 4102
<i>_PS_U_minDC</i>	Minimum permissible DC bus voltage. In increments of 0.1 V.	V - - -	UINT16 R/- per. -	Modbus 4104
<i>_PS_U_minStopDC</i>	DC bus voltage low threshold for Quick Stop. If the threshold is reached, the drive performs a Quick Stop. In increments of 0.1 V.	V - - -	UINT16 R/- per. -	Modbus 4116
<i>_RAMP_p_act</i>	Actual position of profile generator.	usr_p - - -	INT32 R/- - -	Modbus 7940

Parameter name HMI menu HMI name	Description	Unit Minimum value Factory setting Maximum value	Data type R/W Persistent Expert	Parameter address via fieldbus
<i>_RAMP_p_target</i>	Target position of profile generator. Absolute position value of the profile generator, calculated on the basis of the relative and absolute position values received.	usr_p - - -	INT32 R/- - -	Modbus 7938
<i>_RAMP_v_act</i>	Actual velocity of profile generator.	usr_v - - -	INT32 R/- - -	Modbus 7948
<i>_RAMP_v_target</i>	Target velocity of profile generator.	usr_v - - -	INT32 R/- - -	Modbus 7946
<i>_RES_load</i> <i>Π ο ς</i> <i>L d F b</i>	Load of braking resistor. The braking resistor set via parameter RESint_ext is monitored.	% - - -	INT16 R/- - -	Modbus 7208
<i>_RES_maxoverload</i>	Maximum value of overload of braking resistor. Maximum overload of braking resistor during the last 10 seconds. The braking resistor set via parameter RESint_ext is monitored.	% - - -	INT16 R/- - -	Modbus 7210
<i>_RES_overload</i>	Overload of braking resistor (I2t). The braking resistor set via parameter RESint_ext is monitored.	% - - -	INT16 R/- - -	Modbus 7206
<i>_RESint_P</i>	Nominal power of internal braking resistor.	W - - -	UINT16 R/- per. -	Modbus 4114
<i>_RESint_R</i>	Resistance value of internal braking resistor. In increments of 0.01 Ω.	Ω - - -	UINT16 R/- per. -	Modbus 4112
<i>_RMAC_DetailStatus</i>	Detailed status of relative movement after capture (RMAC). 0 / Not Activated: Not activated 1 / Waiting: Waiting for capture signal 2 / Moving: Relative movement after capture running 3 / Interrupted: Relative movement after capture interrupted 4 / Finished: Relative movement after capture terminated Available with firmware version ≥V01.16.	- - - -	UINT16 R/- - -	Modbus 8996

Parameter name HMI menu HMI name	Description	Unit Minimum value Factory setting Maximum value	Data type R/W Persistent Expert	Parameter address via fieldbus
<i>_RMAC_Status</i>	Status of relative movement after capture. 0 / Not Active: Not active 1 / Active Or Finished: Relative movement after capture is active or finished Available with firmware version \geq V01.10.	- 0 - 1	UINT16 R/- - -	Modbus 8994
<i>_ScalePOSmax</i>	Maximum user-defined value for positions. This value depends on ScalePOSdenom and ScalePOSnum.	usr_p - - -	INT32 R/- - -	Modbus 7956
<i>_ScaleRAMPmax</i>	Maximum user-defined value for acceleration and deceleration. This value depends on ScaleRAMPdenom and ScaleRAMPnum.	usr_a - - -	INT32 R/- - -	Modbus 7960
<i>_ScaleVELmax</i>	Maximum user-defined value for velocity. This value depends on ScaleVELdenom and ScaleVELnum.	usr_v - - -	INT32 R/- - -	Modbus 7958
<i>_tq_act</i>	Actual torque. Positive value: Actual torque in positive direction of movement Negative value: Actual torque in negative direction of movement 100.0 % correspond to the continuous stall torque <i>_M_M_0</i> . In increments of 0.1 %.	% - - -	INT16 R/- - -	Modbus 7752
<i>_Ud_ref</i>	Reference motor voltage d component. In increments of 0.1 V.	V - - -	INT16 R/- - -	Modbus 7690
<i>_UDC_act</i> <i>Π ο ς</i> <i>υ d c R</i>	Voltage at DC bus. In increments of 0.1 V.	V - - -	UINT16 R/- - -	Modbus 7198
<i>_Udq_ref</i>	Total motor voltage (vector sum d components and q components). Square root of ($_{Uq_ref}^2 + _{Ud_ref}^2$) In increments of 0.1 V.	V - - -	INT16 R/- - -	Modbus 7692
<i>_Uq_ref</i>	Reference motor voltage q component. In increments of 0.1 V.	V - - -	INT16 R/- - -	Modbus 7688

Parameter name HMI menu HMI name	Description	Unit Minimum value Factory setting Maximum value	Data type R/W Persistent Expert	Parameter address via fieldbus
<i>_v_act</i> <i>Π ο ν</i> <i>V R c t</i>	Actual velocity.	usr_v - - -	INT32 R/- - -	Modbus 7744
<i>_v_act_ENC1</i>	Actual velocity of encoder 1. Available with firmware version ≥V01.03.	usr_v - - -	INT32 R/- - -	Modbus 7762
<i>_v_dif_usr</i>	Load-dependent velocity deviation. The load-dependent velocity deviation is the difference between reference velocity and actual velocity. Available with firmware version ≥V01.26.	usr_v -2147483648 - 2147483647	INT32 R/- - -	Modbus 7768
<i>_v_PTI_act</i>	Actual velocity at PTI interface. Determined pulse frequency at position interface PTI.	Inc/s -2147483648 - 2147483647	INT32 R/- - -	Modbus 2060
<i>_v_ref</i> <i>Π ο ν</i> <i>V r E F</i>	Reference velocity.	usr_v - - -	INT32 R/- - -	Modbus 7742
<i>_Vmax_act</i>	Currently effective velocity limitation. Value of the currently effective velocity limitation. This is one of the following values (whichever is lowest): - CTRL_v_max - M_n_max (only if motor is connected) - Velocity limitation via analog input - Velocity limitation via digital input	usr_v - - -	UINT32 R/- - -	Modbus 7250
<i>_VoltUtil</i> <i>Π ο ν</i> <i>υ d c r</i>	Degree of utilization of DC bus voltage. With a value of 100%, the drive operates at the voltage limit.	% - - -	INT16 R/- - -	Modbus 7718
<i>AbsHomeRequest</i>	Absolute positioning only after homing. 0 / No: No 1 / Yes: Yes This parameter has no function if the parameter 'PP_ModeRangeLim' is set to '1' which allows overtraveling of the movement range (ref_ok is set to 0 when the range is overtraveled). Modified settings become active immediately.	- 0 0 1	UINT16 R/W per. -	Modbus 1580

Parameter name HMI menu HMI name	Description	Unit Minimum value Factory setting Maximum value	Data type R/W Persistent Expert	Parameter address via fieldbus
<i>AccessLock</i>	Locking other access channels. Value 0: Allow control via other access channels Value 1: Lock control via other access channels Example: The access channel is used by the fieldbus. In this case, control via the commissioning software, for example, is not possible. The access channel can only be locked after the currently active operating mode has terminated. Modified settings become active immediately.	- 0 0 1	UINT16 R/W - -	Modbus 284
<i>AI1_I_max</i> <i>CONF → i - o -</i> <i>R I L</i>	Analog 1: Limitation of current at 10 V. In increments of 0.01 A _{rms} . Setting can only be modified if power stage is disabled. Modified settings become active the next time the power stage is enabled.	A _{rms} 0.00 3.00 463.00	UINT16 R/W per. -	Modbus 2334
<i>AI1_M_scale</i> <i>CONF → i - o -</i> <i>R I S</i>	Analog 1: Target torque at 10 V in operating mode Profile Torque. 100.0 % correspond to the continuous stall torque <i>_M_M_0</i> . By using a negative sign, you can invert the evaluation of the analog signal. In increments of 0.1 %. Modified settings become active immediately.	% -3000.0 100.0 3000.0	INT16 R/W per. -	Modbus 2340
<i>AI1_mode</i> <i>CONF → i - o -</i> <i>R I O</i>	Analog 1: Type of usage. 0 / None / none : No function 1 / Target Velocity / SPd5 : Target velocity for the velocity controller 2 / Target Torque / Trq5 : Target torque for the current controller 3 / Velocity Limitation / LSPd : Limitation of the reference velocity for the velocity controller 4 / Current Limitation / Lcur : Limitation of the reference current for the current controller Setting can only be modified if power stage is disabled. Modified settings become active the next time the power stage is enabled.	- 0 1 4	UINT16 R/W per. -	Modbus 2332
<i>AI1_offset</i> <i>CONF → i - o -</i> <i>R I O F</i>	Analog 1: Offset voltage. The analog input AI1 is corrected/offset by the offset value. If you have defined a zero voltage window, this window is effective in the zero pass range of the corrected analog input AI1. Modified settings become active immediately.	mV -5000 0 5000	INT16 R/W per. -	Modbus 2326
<i>AI1_Tau</i> <i>CONF → i - o -</i> <i>R I F t</i>	Analog 1: Filter time constant. First-order low pass (PT1) filter time constant for analog input AI1. In increments of 0.01 ms. Modified settings become active immediately.	ms 0.00 0.00 327.67	UINT16 R/W per. -	Modbus 2308

Parameter name HMI menu HMI name	Description	Unit Minimum value Factory setting Maximum value	Data type R/W Persistent Expert	Parameter address via fieldbus
<i>A11_v_max</i>	Analog 1: Limitation of velocity at 10 V. The maximum velocity is limited to the setting in CTRL_v_max. The minimum velocity is internally limited to 100 RPM. Setting can only be modified if power stage is disabled. Modified settings become active the next time the power stage is enabled.	usr_v 1 3000 2147483647	UINT32 R/W per. -	Modbus 2336
<i>A11_v_scale</i>	Analog 1: Target velocity at 10 V in operating mode Profile Velocity. The maximum velocity is limited to the setting in CTRL_v_max. By using a negative sign, you can invert the evaluation of the analog signal. Modified settings become active immediately.	usr_v -2147483648 6000 2147483647	INT32 R/W per. -	Modbus 2338
<i>A11_win</i> <i>CONF → 1 - 0 -</i> <i>R1Wn</i>	Analog 1: Zero voltage window. Threshold value up to which an input voltage value is treated as 0 V. Example: Value 20, this means a range from -20 ... +20 mV is treated as 0 mV. Modified settings become active immediately.	mV 0 0 1000	UINT16 R/W per. -	Modbus 2322
<i>A12_I_max</i> <i>CONF → 1 - 0 -</i> <i>R2IL</i>	Analog 2: Limitation of current at 10 V. In increments of 0.01 A _{rms} . Setting can only be modified if power stage is disabled. Modified settings become active the next time the power stage is enabled.	A _{rms} 0.00 3.00 463.00	UINT16 R/W per. -	Modbus 2344
<i>A12_M_scale</i> <i>CONF → 1 - 0 -</i> <i>R2IS</i>	Analog 2: Target torque at 10 V in operating mode Profile Torque. 100.0 % correspond to the continuous stall torque _M_M_0. By using a negative sign, you can invert the evaluation of the analog signal. In increments of 0.1 %. Modified settings become active immediately.	% -3000.0 100.0 3000.0	INT16 R/W per. -	Modbus 2350

Parameter name HMI menu HMI name	Description	Unit Minimum value Factory setting Maximum value	Data type R/W Persistent Expert	Parameter address via fieldbus
<i>AI2_mode</i> <i>CONF → I - 0 -</i> <i>R2Po</i>	Analog 2: Type of usage. 0 / None / none : No function 1 / Target Velocity / SPd5 : Target velocity for the velocity controller 2 / Target Torque / Trq5 : Target torque for the current controller 3 / Velocity Limitation / LSPd : Limitation of the reference velocity for the velocity controller 4 / Current Limitation / Lcur : Limitation of the reference current for the current controller 5 / Reserved / rsvd : Reserved Setting can only be modified if power stage is disabled. Modified settings become active the next time the power stage is enabled.	- 0 0 5	UINT16 R/W per. -	Modbus 2342
<i>AI2_offset</i> <i>CONF → I - 0 -</i> <i>R2oF</i>	Analog 2: Offset voltage. The analog input AI2 is corrected/offset by the offset value. If you have defined a zero voltage window, this window is effective in the zero pass range of the corrected analog input AI2. Modified settings become active immediately.	mV -5000 0 5000	INT16 R/W per. -	Modbus 2328
<i>AI2_Tau</i> <i>CONF → I - 0 -</i> <i>R2Ft</i>	Analog 2: Filter time constant. First-order low pass (PT1) filter time constant for analog input AI2. In increments of 0.01 ms. Modified settings become active immediately.	ms 0.00 0.00 327.67	UINT16 R/W per. -	Modbus 2352
<i>AI2_v_max</i>	Analog 2: Limitation of velocity at 10 V. The maximum velocity is limited to the setting in CTRL_v_max. The minimum velocity is internally limited to 100 RPM. Setting can only be modified if power stage is disabled. Modified settings become active the next time the power stage is enabled.	usr_v 1 3000 2147483647	UINT32 R/W per. -	Modbus 2346
<i>AI2_v_scale</i>	Analog 2: Target velocity at 10 V in operating mode Profile Velocity. The maximum velocity is limited to the setting in CTRL_v_max. By using a negative sign, you can invert the evaluation of the analog signal. Modified settings become active immediately.	usr_v -2147483648 6000 2147483647	INT32 R/W per. -	Modbus 2348
<i>AI2_win</i> <i>CONF → I - 0 -</i> <i>R2Wn</i>	Analog 2: Zero voltage window. Threshold value up to which an input voltage value is treated as 0 V. Example: Value 20, this means a range from -20 ... +20 mV is treated as 0 mV. Modified settings become active immediately.	mV 0 0 1000	UINT16 R/W per. -	Modbus 2324

Parameter name HMI menu HMI name	Description	Unit Minimum value Factory setting Maximum value	Data type R/W Persistent Expert	Parameter address via fieldbus
<i>AT_dir</i> P → t u n - 5 t , n	<p>Direction of movement for Autotuning.</p> <p>1 / Positive Negative Home / P n h: Positive direction first, then negative direction with return to initial position</p> <p>2 / Negative Positive Home / n P h: Negative direction first, then positive direction with return to initial position</p> <p>3 / Positive Home / P - h: Positive direction only with return to initial position</p> <p>4 / Positive / P - -: Positive direction only without return to initial position</p> <p>5 / Negative Home / n - h: Negative direction only with return to initial position</p> <p>6 / Negative / n - -: Negative direction only without return to initial position</p> <p>Modified settings become active the next time the motor moves.</p>	- 1 1 6	UINT16 R/W - -	Modbus 12040
<i>AT_dis</i>	<p>Movement range for Autotuning.</p> <p>Movement range within which the control parameters are automatically optimized. The movement range is entered with reference to the actual position.</p> <p>In the case of "Movement in one direction only" (Parameter <i>AT_dir</i>), the specified movement range is used for each optimization step. The movement typically corresponds to 20 times the value, but it is not limited.</p> <p>The parameter <i>AT_dis_usr</i> allows you to enter the value in user-defined units.</p> <p>In increments of 0.1 revolution.</p> <p>Modified settings become active the next time the motor moves.</p>	revolution 1.0 2.0 999.9	UINT32 R/W - -	Modbus 12038
<i>AT_dis_usr</i>	<p>Movement range for Autotuning.</p> <p>Movement range within which the control parameters are automatically optimized. The movement range is entered with reference to the actual position.</p> <p>In the case of "Movement in one direction only" (Parameter <i>AT_dir</i>), the specified range is used for each optimization step. The movement typically corresponds to 20 times the value, but it is not limited.</p> <p>The minimum value, the factory setting and the maximum value depend on the scaling factor.</p> <p>Modified settings become active the next time the motor moves.</p> <p>Available with firmware version ≥V01.05.</p>	usr_p 1 32768 2147483647	INT32 R/W - -	Modbus 12068
<i>AT_mechanical</i>	<p>Type of coupling of the system.</p> <p>1 / Direct Coupling: Direct coupling</p> <p>2 / Belt Axis: Belt axis</p> <p>3 / Spindle Axis: Spindle axis</p> <p>Modified settings become active the next time the motor moves.</p>	- 1 2 3	UINT16 R/W - -	Modbus 12060

Parameter name HMI menu HMI name	Description	Unit Minimum value Factory setting Maximum value	Data type R/W Persistent Expert	Parameter address via fieldbus
<i>AT_n_ref</i>	Velocity jump for Autotuning. The parameter <i>AT_v_ref</i> allows you to enter the value in user-defined units. Modified settings become active the next time the motor moves.	RPM 10 100 1000	UINT32 R/W - -	Modbus 12044
<i>AT_start</i>	Autotuning start. Value 0: Terminate Value 1: Activate EasyTuning Value 2: Activate ComfortTuning Modified settings become active immediately.	- 0 - 2	UINT16 R/W - -	Modbus 12034
<i>AT_v_ref</i>	Velocity jump for Autotuning. The minimum value, the factory setting and the maximum value depend on the scaling factor. Modified settings become active the next time the motor moves. Available with firmware version \geq V01.05.	usr_v 1 100 2147483647	INT32 R/W - -	Modbus 12070
<i>AT_wait</i>	Waiting time between Autotuning steps. Modified settings become active the next time the motor moves.	ms 300 500 10000	UINT16 R/W - -	Modbus 12050
<i>BLSH_Mode</i>	Processing mode of backlash compensation. 0 / Off: Backlash compensation is off 1 / OnAfterPositiveMovement: Backlash compensation is on, last movement was in positive direction 2 / OnAfterNegativeMovement: Backlash compensation is on, last movement was in negative direction Modified settings become active immediately. Available with firmware version \geq V01.14.	- 0 0 2	UINT16 R/W per. -	Modbus 1666
<i>BLSH_Position</i>	Position value for backlash compensation. Setting can only be modified if power stage is disabled. Modified settings become active the next time the power stage is enabled. Available with firmware version \geq V01.14.	usr_p 0 0 2147483647	INT32 R/W per. -	Modbus 1668
<i>BLSH_Time</i>	Processing time for backlash compensation. Value 0: Immediate backlash compensation Value >0: Processing time for backlash compensation Setting can only be modified if power stage is disabled. Modified settings become active the next time the power stage is enabled. Available with firmware version \geq V01.14.	ms 0 0 16383	UINT16 R/W per. -	Modbus 1672

Parameter name HMI menu HMI name	Description	Unit Minimum value Factory setting Maximum value	Data type R/W Persistent Expert	Parameter address via fieldbus
<i>BRK_AddT_apply</i>	<p>Additional time delay for applying the holding brake.</p> <p>The overall time delay for applying the holding brake is the time delay from the electronic nameplate of the motor and the additional time delay in this parameter.</p> <p>Setting can only be modified if power stage is disabled.</p> <p>Modified settings become active the next time the power stage is enabled.</p>	<p>ms</p> <p>0</p> <p>0</p> <p>1000</p>	<p>INT16</p> <p>R/W</p> <p>per.</p> <p>-</p>	Modbus 1296
<i>BRK_AddT_release</i>	<p>Additional time delay for releasing the holding brake.</p> <p>The overall time delay for releasing the holding brake is the time delay from the electronic nameplate of the motor and the additional time delay in this parameter.</p> <p>Setting can only be modified if power stage is disabled.</p> <p>Modified settings become active the next time the power stage is enabled.</p>	<p>ms</p> <p>0</p> <p>0</p> <p>400</p>	<p>INT16</p> <p>R/W</p> <p>per.</p> <p>-</p>	Modbus 1294
<i>CLSET_p_DiffWin</i>	<p>Position deviation for control loop parameter set switching.</p> <p>If the position deviation of the position controller is less than the value of this parameter, control loop parameter set 2 is used. Otherwise, control loop parameter set 1 is used.</p> <p>The parameter <i>CLSET_p_DiffWin_usr</i> allows you to enter the value in user-defined units.</p> <p>In increments of 0.0001 revolution.</p> <p>Modified settings become active immediately.</p>	<p>revolution</p> <p>0.0000</p> <p>0.0100</p> <p>2.0000</p>	<p>UINT16</p> <p>R/W</p> <p>per.</p> <p>-</p>	Modbus 4408
<i>CLSET_p_DiffWin_usr</i>	<p>Position deviation for control loop parameter set switching.</p> <p>If the position deviation of the position controller is less than the value of this parameter, control loop parameter set 2 is used. Otherwise, control loop parameter set 1 is used.</p> <p>The minimum value, the factory setting and the maximum value depend on the scaling factor.</p> <p>Modified settings become active immediately.</p> <p>Available with firmware version \geqV01.05.</p>	<p>usr_p</p> <p>0</p> <p>164</p> <p>2147483647</p>	<p>INT32</p> <p>R/W</p> <p>per.</p> <p>-</p>	Modbus 4426

Parameter name HMI menu HMI name	Description	Unit Minimum value Factory setting Maximum value	Data type R/W Persistent Expert	Parameter address via fieldbus
<i>CLSET_ParSwiCond</i>	<p>Condition for parameter set switching.</p> <p>0 / None Or Digital Input: None or digital input function selected</p> <p>1 / Inside Position Deviation: Inside position deviation (value definition in parameter CLSET_p_DiffWin)</p> <p>2 / Below Reference Velocity: Below reference velocity (value definition in parameter CLSET_v_Threshol)</p> <p>3 / Below Actual Velocity: Below actual velocity (value definition in parameter CLSET_v_Threshol)</p> <p>4 / Reserved: Reserved</p> <p>In the case of parameter set switching, the values of the following parameters are changed gradually:</p> <ul style="list-style-type: none"> - CTRL_KPn - CTRL_TNn - CTRL_KPp - CTRL_TAUref - CTRL_TAUiref - CTRL_KFPp <p>The following parameters are changed immediately after the time for parameter set switching (CTRL_ParChgTime):</p> <ul style="list-style-type: none"> - CTRL_Nf1damp - CTRL_Nf1freq - CTRL_Nf1bandw - CTRL_Nf2damp - CTRL_Nf2freq - CTRL_Nf2bandw - CTRL_Osupdamp - CTRL_Osupdelay - CTRL_Kfric <p>Modified settings become active immediately.</p>	- 0 0 4	UINT16 R/W per. -	Modbus 4404
<i>CLSET_v_Threshol</i>	<p>Velocity threshold for control loop parameter set switching.</p> <p>If the reference velocity or the actual velocity are less than the value of this parameter, control loop parameter set 2 is used. Otherwise, control loop parameter set 1 is used.</p> <p>Modified settings become active immediately.</p>	usr_v 0 50 2147483647	UINT32 R/W per. -	Modbus 4410
<i>CLSET_winTime</i>	<p>Time window for parameter set switching.</p> <p>Value 0: Window monitoring deactivated.</p> <p>Value >0: Window time for the parameters CLSET_v_Threshol and CLSET_p_DiffWin.</p> <p>Modified settings become active immediately.</p>	ms 0 0 1000	UINT16 R/W per. -	Modbus 4406

Parameter name HMI menu HMI name	Description	Unit Minimum value Factory setting Maximum value	Data type R/W Persistent Expert	Parameter address via fieldbus
<i>CommutCntCred</i>	Value for increased threshold for commutation monitoring. This parameter contains the value which is added to the threshold value for commutation monitoring. Setting can only be modified if power stage is disabled. Modified settings become active immediately. Available with firmware version $\geq V01.32$.	- 0 0 1000	INT16 R/W per. expert	Modbus 1404
<i>CommutCntMax</i>	Maximum value the commutation monitoring counter has reached. This parameter contains the maximum value the commutation monitoring counter has reached since power on or reset. The maximum value can be reset by writing the value 0. Available with firmware version $\geq V01.32$.	- - - -	INT16 R/W - expert	Modbus 16326
<i>CTRL_GlobGain</i> P → Tun - Gain	Global gain factor (affects control loop parameter set 1). The global gain factor affects the following parameters of control loop parameter set 1: - CTRL_KPn - CTRL_TNn - CTRL_KPp - CTRL_TAUref The global gain factor is set to 100% - if the control loop parameters are set to default - at the end of the Autotuning process - if control loop parameter set 2 is copied to set 1 via the parameter CTRL_ParSetCopy In increments of 0.1 %. Modified settings become active immediately.	% 5.0 100.0 1000.0	UINT16 R/W per. -	Modbus 4394
<i>CTRL_I_max</i> Conf → dr C - I MAX	Current limitation. During operation, the current limit is one of the following values (whichever is lowest): - CTRL_I_max - M_I_max - PS_I_max - Current limitation via analog input - Current limitation via digital input Limitations caused by I2t monitoring are also taken into account. Default: PS_I_max at 8 kHz PWM frequency and 230/480 V mains voltage In increments of 0.01 A _{rms} . Modified settings become active immediately.	A _{rms} 0.00 - 463.00	UINT16 R/W per. -	Modbus 4376

Parameter name HMI menu HMI name	Description	Unit Minimum value Factory setting Maximum value	Data type R/W Persistent Expert	Parameter address via fieldbus
<i>CTRL_I_max_fw</i>	<p>Maximum current for field weakening (d component).</p> <p>This value is only limited by the minimum/maximum parameter range (no limitation of this value by motor/power stage).</p> <p>The actually effective field weakening current is the minimum of CTRL_I_max_fw and one half of the lower value of the nominal current of the power stage and the motor.</p> <p>In increments of 0.01 A_{rms}.</p> <p>Setting can only be modified if power stage is disabled.</p> <p>Modified settings become active the next time the power stage is enabled.</p>	<p>A_{rms}</p> <p>0.00</p> <p>0.00</p> <p>300.00</p>	<p>UINT16</p> <p>R/W</p> <p>per.</p> <p>expert</p>	Modbus 4382
<i>CTRL_KFAcc</i>	<p>Acceleration feed-forward control.</p> <p>In increments of 0.1 %.</p> <p>Modified settings become active immediately.</p>	<p>%</p> <p>0.0</p> <p>0.0</p> <p>3000.0</p>	<p>UINT16</p> <p>R/W</p> <p>per.</p> <p>expert</p>	Modbus 4372
<i>CTRL_ParChgTime</i>	<p>Period of time for control loop parameter set switching.</p> <p>In the case of control loop parameter set switching, the values of the following parameters are changed linearly:</p> <ul style="list-style-type: none"> - CTRL_KPn - CTRL_TNn - CTRL_KPp - CTRL_TAUref - CTRL_TAUiref - CTRL_KFPp <p>Modified settings become active immediately.</p>	<p>ms</p> <p>0</p> <p>0</p> <p>2000</p>	<p>UINT16</p> <p>R/W</p> <p>per.</p> <p>-</p>	Modbus 4392
<i>CTRL_ParSetCopy</i>	<p>Control loop parameter set copying.</p> <p>Value 1: Copy control loop parameter set 1 to set 2</p> <p>Value 2: Copy control loop parameter set 2 to set 1</p> <p>If control loop parameter set 2 is copied to control loop parameter set 1, the parameter CTRL_GlobGain is set to 100%.</p> <p>Modified settings become active immediately.</p>	<p>-</p> <p>0.0</p> <p>-</p> <p>0.2</p>	<p>UINT16</p> <p>R/W</p> <p>-</p> <p>-</p>	Modbus 4396
<i>CTRL_PwrUpParSet</i>	<p>Selection of control loop parameter set at power up.</p> <p>0 / Switching Condition: The switching condition is used for control loop parameter set switching</p> <p>1 / Parameter Set 1: Control loop parameter set 1 is used</p> <p>2 / Parameter Set 2: Control loop parameter set 2 is used</p> <p>The selected value is also written to CTRL_SelParSet (non-persistent).</p> <p>Modified settings become active immediately.</p>	<p>-</p> <p>0</p> <p>1</p> <p>2</p>	<p>UINT16</p> <p>R/W</p> <p>per.</p> <p>-</p>	Modbus 4400

Parameter name HMI menu HMI name	Description	Unit Minimum value Factory setting Maximum value	Data type R/W Persistent Expert	Parameter address via fieldbus
<i>CTRL_SelParSet</i>	Selection of control loop parameter set. Coding see parameter: CTRL_PwrUpParSet Modified settings become active immediately.	- 0 1 2	UINT16 R/W - -	Modbus 4402
<i>CTRL_SmoothCurr</i>	Smoothing factor for current controller. This parameter decreases the dynamics of the current control loop. Modified settings become active immediately. Available with firmware version \geq V01.26.	% 50 100 100	UINT16 R/W per. -	Modbus 4428
<i>CTRL_SpdFric</i>	Speed of rotation up to which the friction compensation is linear. Modified settings become active immediately.	RPM 0 5 20	UINT32 R/W per. expert	Modbus 4370
<i>CTRL_TAUact</i>	Filter time constant to smooth velocity of motor. The default value is calculated on the basis of the motor data. In increments of 0.01 ms. Modified settings become active immediately.	ms 0.00 - 30.00	UINT16 R/W per. expert	Modbus 4368
<i>CTRL_v_max</i> <i>CONF → drC - nMAX</i>	Velocity limitation. During operation, the velocity limit is one of the following values (whichever is lowest): - CTRL_v_max - M_n_max - Velocity limitation via analog input - Velocity limitation via digital input Modified settings become active immediately.	usr_v 1 13200 2147483647	UINT32 R/W per. -	Modbus 4384
<i>CTRL_VelObsActiv</i>	Activation of velocity observer. 0 / Velocity Observer Off: Velocity observer is off 1 / Velocity Observer Passive: Velocity observer is on, but not used for motor control 2 / Velocity Observer Active: Velocity observer is on and used for motor control Velocity observer control reduces velocity ripple and enhances controller bandwidth. Set the correct dynamics and inertia values before activation. Setting can only be modified if power stage is disabled. Modified settings become active immediately. Available with firmware version \geq V01.03.	- 0 0 2	UINT16 R/W per. expert	Modbus 4420

Parameter name HMI menu HMI name	Description	Unit Minimum value Factory setting Maximum value	Data type R/W Persistent Expert	Parameter address via fieldbus
<i>CTRL_VelObsDyn</i>	Dynamics of velocity observer. The value of this parameter must be less than (for example, between 5 % and 20 %) the integral action time of the velocity controller (parameter CTRL1_TNn und CTRL2_TNn). In increments of 0.01 ms. Setting can only be modified if power stage is disabled. Modified settings become active immediately. Available with firmware version \geq V01.03.	ms 0.03 0.25 200.00	UINT16 R/W per. expert	Modbus 4422
<i>CTRL_VelObsInert</i>	Inertia value for velocity observer. System inertia that is used for velocity observer calculations. The default value is the inertia of the mounted motor. In the case of autotuning, the value of this parameter can be set equal to that of <i>_AT_J</i> . Setting can only be modified if power stage is disabled. Modified settings become active immediately. Available with firmware version \geq V01.03.	g cm ² 1 - 2147483648	UINT32 R/W per. expert	Modbus 4424
<i>CTRL_vPIDDPart</i>	PID velocity controller: D gain. In increments of 0.1 %. Modified settings become active immediately.	% 0.0 0.0 400.0	UINT16 R/W per. expert	Modbus 4364
<i>CTRL_vPIDDTime</i>	PID velocity controller: Time constant of D term smoothing filter. In increments of 0.01 ms. Modified settings become active immediately.	ms 0.01 0.25 10.00	UINT16 R/W per. expert	Modbus 4362
<i>CTRL1_KFPP</i> <i>Control → Drive - F P P I</i>	Velocity feed-forward control. In the case of switching between the two control loop parameter sets, the values are changed linearly over the time defined in the parameter CTRL_ParChgTime. In increments of 0.1 %. Modified settings become active immediately.	% 0.0 0.0 200.0	UINT16 R/W per. -	Modbus 4620
<i>CTRL1_Kfric</i>	Friction compensation: Gain. In increments of 0.01 A _{rms} . Modified settings become active immediately.	A _{rms} 0.00 0.00 10.00	UINT16 R/W per. expert	Modbus 4640

Parameter name HMI menu HMI name	Description	Unit Minimum value Factory setting Maximum value	Data type R/W Persistent Expert	Parameter address via fieldbus
<i>CTRL1_KPn</i> <i>Control → Drive - Pn I</i>	Velocity controller P gain. The default value is calculated on the basis of the motor parameters. In the case of switching between the two control loop parameter sets, the values are changed linearly over the time defined in the parameter CTRL_ParChgTime. In increments of 0.0001 A/RPM. Modified settings become active immediately.	A/RPM 0.0001 - 2.5400	UINT16 R/W per. -	Modbus 4610
<i>CTRL1_KPp</i> <i>Control → Drive - Pp I</i>	Position controller P gain. The default value is calculated. In the case of switching between the two control loop parameter sets, the values are changed linearly over the time defined in the parameter CTRL_ParChgTime. In increments of 0.1 1/s. Modified settings become active immediately.	1/s 2.0 - 900.0	UINT16 R/W per. -	Modbus 4614
<i>CTRL1_Nf1bandw</i>	Notch filter 1: Bandwidth. Definition of bandwidth: $1 - F_b/F_0$ In increments of 0.1 %. Modified settings become active immediately.	% 1.0 70.0 90.0	UINT16 R/W per. expert	Modbus 4628
<i>CTRL1_Nf1damp</i>	Notch filter 1: Damping. In increments of 0.1 %. Modified settings become active immediately.	% 55.0 90.0 99.0	UINT16 R/W per. expert	Modbus 4624
<i>CTRL1_Nf1freq</i>	Notch filter 1: Frequency. The filter is deactivated at a value of 15000. In increments of 0.1 Hz. Modified settings become active immediately.	Hz 50.0 1500.0 1500.0	UINT16 R/W per. expert	Modbus 4626
<i>CTRL1_Nf2bandw</i>	Notch filter 2: Bandwidth. Definition of bandwidth: $1 - F_b/F_0$ In increments of 0.1 %. Modified settings become active immediately.	% 1.0 70.0 90.0	UINT16 R/W per. expert	Modbus 4634
<i>CTRL1_Nf2damp</i>	Notch filter 2: Damping. In increments of 0.1 %. Modified settings become active immediately.	% 55.0 90.0 99.0	UINT16 R/W per. expert	Modbus 4630
<i>CTRL1_Nf2freq</i>	Notch filter 2: Frequency. The filter is deactivated at a value of 15000. In increments of 0.1 Hz. Modified settings become active immediately.	Hz 50.0 1500.0 1500.0	UINT16 R/W per. expert	Modbus 4632

Parameter name HMI menu HMI name	Description	Unit Minimum value Factory setting Maximum value	Data type R/W Persistent Expert	Parameter address via fieldbus
<i>CTRL1_Osupdamp</i>	Overshoot suppression filter: Damping. The filter is deactivated at a value of 0. In increments of 0.1 %. Modified settings become active immediately.	% 0.0 0.0 50.0	UINT16 R/W per. expert	Modbus 4636
<i>CTRL1_Osupdelay</i>	Overshoot suppression filter: Time delay. The filter is deactivated at a value of 0. In increments of 0.01 ms. Modified settings become active immediately.	ms 0.00 0.00 75.00	UINT16 R/W per. expert	Modbus 4638
<i>CTRL1_TAUiref</i>	Filter time constant of the reference current value filter. In the case of switching between the two control loop parameter sets, the values are changed linearly over the time defined in the parameter CTRL_ParChgTime. In increments of 0.01 ms. Modified settings become active immediately.	ms 0.00 0.50 4.00	UINT16 R/W per. -	Modbus 4618
<i>CTRL1_TAUiref</i> <i>CONF → drC -</i> <i>TRU I</i>	Filter time constant of the reference velocity value filter. In the case of switching between the two control loop parameter sets, the values are changed linearly over the time defined in the parameter CTRL_ParChgTime. In increments of 0.01 ms. Modified settings become active immediately.	ms 0.00 9.00 327.67	UINT16 R/W per. -	Modbus 4616
<i>CTRL1_TNn</i> <i>CONF → drC -</i> <i>TRU I</i>	Velocity controller integral action time. The default value is calculated. In the case of switching between the two control loop parameter sets, the values are changed linearly over the time defined in the parameter CTRL_ParChgTime. In increments of 0.01 ms. Modified settings become active immediately.	ms 0.00 - 327.67	UINT16 R/W per. -	Modbus 4612
<i>CTRL2_KFpp</i> <i>CONF → drC -</i> <i>FPP 2</i>	Velocity feed-forward control. In the case of switching between the two control loop parameter sets, the values are changed linearly over the time defined in the parameter CTRL_ParChgTime. In increments of 0.1 %. Modified settings become active immediately.	% 0.0 0.0 200.0	UINT16 R/W per. -	Modbus 4876
<i>CTRL2_Kfric</i>	Friction compensation: Gain. In increments of 0.01 A _{rms} . Modified settings become active immediately.	A _{rms} 0.00 0.00 10.00	UINT16 R/W per. expert	Modbus 4896

Parameter name HMI menu HMI name	Description	Unit Minimum value Factory setting Maximum value	Data type R/W Persistent Expert	Parameter address via fieldbus
<i>CTRL2_KPn</i> <i>Control → drv - Pn</i>	Velocity controller P gain. The default value is calculated on the basis of the motor parameters. In the case of switching between the two control loop parameter sets, the values are changed linearly over the time defined in the parameter CTRL_ParChgTime. In increments of 0.0001 A/RPM. Modified settings become active immediately.	A/RPM 0.0001 - 2.5400	UINT16 R/W per. -	Modbus 4866
<i>CTRL2_KPp</i> <i>Control → drv - Pp</i>	Position controller P gain. The default value is calculated. In the case of switching between the two control loop parameter sets, the values are changed linearly over the time defined in the parameter CTRL_ParChgTime. In increments of 0.1 1/s. Modified settings become active immediately.	1/s 2.0 - 900.0	UINT16 R/W per. -	Modbus 4870
<i>CTRL2_Nf1bandw</i>	Notch filter 1: Bandwidth. Definition of bandwidth: $1 - F_b/F_0$ In increments of 0.1 %. Modified settings become active immediately.	% 1.0 70.0 90.0	UINT16 R/W per. expert	Modbus 4884
<i>CTRL2_Nf1damp</i>	Notch filter 1: Damping. In increments of 0.1 %. Modified settings become active immediately.	% 55.0 90.0 99.0	UINT16 R/W per. expert	Modbus 4880
<i>CTRL2_Nf1freq</i>	Notch filter 1: Frequency. The filter is deactivated at a value of 15000. In increments of 0.1 Hz. Modified settings become active immediately.	Hz 50.0 1500.0 1500.0	UINT16 R/W per. expert	Modbus 4882
<i>CTRL2_Nf2bandw</i>	Notch filter 2: Bandwidth. Definition of bandwidth: $1 - F_b/F_0$ In increments of 0.1 %. Modified settings become active immediately.	% 1.0 70.0 90.0	UINT16 R/W per. expert	Modbus 4890
<i>CTRL2_Nf2damp</i>	Notch filter 2: Damping. In increments of 0.1 %. Modified settings become active immediately.	% 55.0 90.0 99.0	UINT16 R/W per. expert	Modbus 4886
<i>CTRL2_Nf2freq</i>	Notch filter 2: Frequency. The filter is deactivated at a value of 15000. In increments of 0.1 Hz. Modified settings become active immediately.	Hz 50.0 1500.0 1500.0	UINT16 R/W per. expert	Modbus 4888

Parameter name HMI menu HMI name	Description	Unit Minimum value Factory setting Maximum value	Data type R/W Persistent Expert	Parameter address via fieldbus
<i>CTRL2_Osupdamp</i>	Overshoot suppression filter: Damping. The filter is deactivated at a value of 0. In increments of 0.1 %. Modified settings become active immediately.	% 0.0 0.0 50.0	UINT16 R/W per. expert	Modbus 4892
<i>CTRL2_Osupdelay</i>	Overshoot suppression filter: Time delay. The filter is deactivated at a value of 0. In increments of 0.01 ms. Modified settings become active immediately.	ms 0.00 0.00 75.00	UINT16 R/W per. expert	Modbus 4894
<i>CTRL2_TAUiref</i>	Filter time constant of the reference current value filter. In the case of switching between the two control loop parameter sets, the values are changed linearly over the time defined in the parameter CTRL_ParChgTime. In increments of 0.01 ms. Modified settings become active immediately.	ms 0.00 0.50 4.00	UINT16 R/W per. -	Modbus 4874
<i>CTRL2_TAUunref</i> <i>CONF → dr C -</i> <i>EAU2</i>	Filter time constant of the reference velocity value filter. In the case of switching between the two control loop parameter sets, the values are changed linearly over the time defined in the parameter CTRL_ParChgTime. In increments of 0.01 ms. Modified settings become active immediately.	ms 0.00 9.00 327.67	UINT16 R/W per. -	Modbus 4872
<i>CTRL2_TNn</i> <i>CONF → dr C -</i> <i>Ein2</i>	Velocity controller integral action time. The default value is calculated. In the case of switching between the two control loop parameter sets, the values are changed linearly over the time defined in the parameter CTRL_ParChgTime. In increments of 0.01 ms. Modified settings become active immediately.	ms 0.00 - 327.67	UINT16 R/W per. -	Modbus 4868
<i>DCbus_compat</i>	DC bus compatibility LXM32 and ATV32. 0 / No DC bus or LXM32 only: DC bus not used or only LXM32 connected via the DC bus 1 / DC bus with LXM32 and ATV32: LXM32 and ATV32 connected via the DC bus Setting can only be modified if power stage is disabled. Modified settings become active the next time the product is powered on. Available with firmware version ≥V01.05.	- 0 0 1	UINT16 R/W per. -	Modbus 1356

Parameter name HMI menu HMI name	Description	Unit Minimum value Factory setting Maximum value	Data type R/W Persistent Expert	Parameter address via fieldbus
<i>DCOMcontrol</i>	<p>DriveCom control word.</p> <p>See Operation, Operating States, for bit assignment information.</p> <p>Bit 0: Operating state Switch On</p> <p>Bit 1: Enable Voltage</p> <p>Bit 2: Operating state Quick Stop</p> <p>Bit 3: Enable Operation</p> <p>Bits 4 ... 6: Operating mode-specific</p> <p>Bit 7: Fault Reset</p> <p>Bit 8: Halt</p> <p>Bit 9: Operating mode-specific</p> <p>Bits 10 ... 15: Reserved (must be 0)</p> <p>Modified settings become active immediately.</p>	- - - -	UINT16 R/W - -	Modbus 6914
<i>DI_0_Debounce</i>	<p>Debounce time of DI0.</p> <p>0 / No: No software debouncing</p> <p>1 / 0.25 ms: 0.25 ms</p> <p>2 / 0.50 ms: 0.50 ms</p> <p>3 / 0.75 ms: 0.75 ms</p> <p>4 / 1.00 ms: 1.00 ms</p> <p>5 / 1.25 ms: 1.25 ms</p> <p>6 / 1.50 ms: 1.50 ms</p> <p>Setting can only be modified if power stage is disabled.</p> <p>Modified settings become active immediately.</p>	- 0 6 6	UINT16 R/W per. -	Modbus 2112
<i>DI_1_Debounce</i>	<p>Debounce time of DI1.</p> <p>0 / No: No software debouncing</p> <p>1 / 0.25 ms: 0.25 ms</p> <p>2 / 0.50 ms: 0.50 ms</p> <p>3 / 0.75 ms: 0.75 ms</p> <p>4 / 1.00 ms: 1.00 ms</p> <p>5 / 1.25 ms: 1.25 ms</p> <p>6 / 1.50 ms: 1.50 ms</p> <p>Setting can only be modified if power stage is disabled.</p> <p>Modified settings become active immediately.</p>	- 0 6 6	UINT16 R/W per. -	Modbus 2114

Parameter name HMI menu HMI name	Description	Unit Minimum value Factory setting Maximum value	Data type R/W Persistent Expert	Parameter address via fieldbus
<i>DI_2_Debounce</i>	Debounce time of DI2. 0 / No: No software debouncing 1 / 0.25 ms: 0.25 ms 2 / 0.50 ms: 0.50 ms 3 / 0.75 ms: 0.75 ms 4 / 1.00 ms: 1.00 ms 5 / 1.25 ms: 1.25 ms 6 / 1.50 ms: 1.50 ms Setting can only be modified if power stage is disabled. Modified settings become active immediately.	- 0 6 6	UINT16 R/W per. -	Modbus 2116
<i>DI_3_Debounce</i>	Debounce time of DI3. 0 / No: No software debouncing 1 / 0.25 ms: 0.25 ms 2 / 0.50 ms: 0.50 ms 3 / 0.75 ms: 0.75 ms 4 / 1.00 ms: 1.00 ms 5 / 1.25 ms: 1.25 ms 6 / 1.50 ms: 1.50 ms Setting can only be modified if power stage is disabled. Modified settings become active immediately.	- 0 6 6	UINT16 R/W per. -	Modbus 2118
<i>DI_4_Debounce</i>	Debounce time of DI4. 0 / No: No software debouncing 1 / 0.25 ms: 0.25 ms 2 / 0.50 ms: 0.50 ms 3 / 0.75 ms: 0.75 ms 4 / 1.00 ms: 1.00 ms 5 / 1.25 ms: 1.25 ms 6 / 1.50 ms: 1.50 ms Setting can only be modified if power stage is disabled. Modified settings become active immediately.	- 0 6 6	UINT16 R/W per. -	Modbus 2120

Parameter name	Description	Unit	Data type	Parameter address via fieldbus
HMI menu		Minimum value	R/W	
HMI name		Factory setting	Persistent	
		Maximum value	Expert	
<i>DI_5_Debounce</i>	Debounce time of DI5. 0 / No: No software debouncing 1 / 0.25 ms: 0.25 ms 2 / 0.50 ms: 0.50 ms 3 / 0.75 ms: 0.75 ms 4 / 1.00 ms: 1.00 ms 5 / 1.25 ms: 1.25 ms 6 / 1.50 ms: 1.50 ms Setting can only be modified if power stage is disabled. Modified settings become active immediately.	- 0 6 6	UINT16 R/W per. -	Modbus 2122
<i>DPL_dmControl</i>	Drive Profile Lexium dmControl.	- - - -	UINT16 R/W - -	Modbus 6974
<i>DPL_intLim</i>	Setting for bit 9 of <code>_DPL_motionStat</code> and <code>_actionStatus</code> . 0 / None: Not used (reserved) 1 / Current Below Threshold: Current threshold value 2 / Velocity Below Threshold: Velocity threshold value 3 / In Position Deviation Window: Position deviation window 4 / In Velocity Deviation Window: Velocity deviation window 9 / Hardware Limit Switch: Hardware limit switch 10 / RMAC active or finished: Relative movement after capture is active or finished 11 / Position Window: Position window Setting for: Bit 9 of the parameter <code>_actionStatus</code> Bit 9 of the parameter <code>_DPL_motionStat</code> Modified settings become active immediately. Available with firmware version $\geq V01.08$.	- 0 11 11	UINT16 R/W per. -	Modbus 7018
<i>DPL_RefA16</i>	Drive Profile Lexium RefA16.	- - - -	INT16 R/W - -	Modbus 6980
<i>DPL_RefB32</i>	Drive Profile Lexium RefB32.	- - - -	INT32 R/W - -	Modbus 6978

Parameter name	Description	Unit	Data type	Parameter address via fieldbus
HMI menu		Minimum value	R/W	
HMI name		Factory setting	Persistent	
		Maximum value	Expert	
<i>DS402intLim</i>	<p>DS402 status word: Setting for bit 11 (internal limit).</p> <p>0 / None: Not used (reserved)</p> <p>1 / Current Below Threshold: Current threshold value</p> <p>2 / Velocity Below Threshold: Velocity threshold value</p> <p>3 / In Position Deviation Window: Position deviation window</p> <p>4 / In Velocity Deviation Window: Velocity deviation window</p> <p>9 / Hardware Limit Switch: Hardware limit switch</p> <p>10 / RMAC active or finished: Relative movement after capture is active or finished</p> <p>11 / Position Window: Position window</p> <p>Setting for:</p> <p>Bit 11 of the parameter <code>_DCOMstatus</code></p> <p>Bit 10 of the parameter <code>_actionStatus</code></p> <p>Bit 10 of the parameter <code>_DPL_motionStat</code></p> <p>Modified settings become active immediately.</p>	- 0 0 11	UINT16 R/W per. -	Modbus 6972
<p><i>DSM_ShutDownOption</i></p> <p><i>C o n F → A C G - S d L Y</i></p>	<p>Behavior for disabling the power stage during movement.</p> <p>0 / Disable Immediately / d i S i : Disable power stage immediately</p> <p>1 / Disable After Halt / d i S h : Disable power stage after deceleration to standstill</p> <p>This parameter specifies the response to a power stage disable request.</p> <p>Halt is used for deceleration to standstill.</p> <p>Modified settings become active immediately.</p> <p>Available with firmware version \geqV01.26.</p>	- 0 0 1	INT16 R/W per. -	Modbus 1684

Parameter name HMI menu HMI name	Description	Unit Minimum value Factory setting Maximum value	Data type R/W Persistent Expert	Parameter address via fieldbus
<i>ENC1_adjustment</i>	<p>Adjustment of absolute position of encoder 1.</p> <p>The value range depends on the encoder type.</p> <p>Singleturn encoder: 0 ... x-1</p> <p>Multiturn encoder: 0 ... (4096*x)-1</p> <p>Singleturn encoder (shifted with parameter <i>ShiftEncWorkRang</i>): -(x/2) ... (x/2)-1</p> <p>Multiturn encoder (shifted with parameter <i>ShiftEncWorkRang</i>): -(2048*x) ... (2048*x)-1</p> <p>Definition of 'x': Maximum position for one encoder turn in user-defined units. This value is 16384 with the default scaling.</p> <p>If processing is to be performed with inversion of the direction of movement, this must be set before the encoder position is adjusted.</p> <p>After the write access, a wait time of at least 1 second is required before the drive can be powered off.</p> <p>Modified settings become active the next time the product is powered on.</p>	usr_p - - -	INT32 R/W - -	Modbus 1324
<i>ErrorResp_Flt_AC</i>	<p>Error response to missing mains phase.</p> <p>0 / Error Class 0: Error class 0</p> <p>1 / Error Class 1: Error class 1</p> <p>2 / Error Class 2: Error class 2</p> <p>3 / Error Class 3: Error class 3</p> <p>Setting can only be modified if power stage is disabled.</p> <p>Modified settings become active the next time the power stage is enabled.</p>	- 0 2 3	UINT16 R/W per. -	Modbus 1300
<i>ErrorResp_I2tRES</i>	<p>Error response to 100% I2t braking resistor.</p> <p>0 / Error Class 0: Error class 0</p> <p>1 / Error Class 1: Error class 1</p> <p>2 / Error Class 2: Error class 2</p> <p>Setting can only be modified if power stage is disabled.</p> <p>Modified settings become active the next time the power stage is enabled.</p>	- 0 0 2	UINT16 R/W per. -	Modbus 1348

Parameter name HMI menu HMI name	Description	Unit Minimum value Factory setting Maximum value	Data type R/W Persistent Expert	Parameter address via fieldbus
<i>ErrorResp_p_dif</i>	<p>Error response to excessively high load-dependent position deviation.</p> <p>1 / Error Class 1: Error class 1</p> <p>2 / Error Class 2: Error class 2</p> <p>3 / Error Class 3: Error class 3</p> <p>Setting can only be modified if power stage is disabled.</p> <p>Modified settings become active the next time the power stage is enabled.</p>	- 1 3 3	UINT16 R/W per. -	Modbus 1302
<i>ErrorResp_QuasiAbs</i>	<p>Error response to detected error with quasi absolute position.</p> <p>3 / Error Class 3: Error class 3</p> <p>4 / Error Class 4: Error class 4</p> <p>Setting can only be modified if power stage is disabled.</p> <p>Modified settings become active the next time the power stage is enabled.</p> <p>Available with firmware version \geqV01.26.</p>	- 3 3 4	UINT16 R/W per. -	Modbus 1396
<i>ErrorResp_v_dif</i>	<p>Error response to excessively high load-dependent velocity deviation.</p> <p>1 / Error Class 1: Error class 1</p> <p>2 / Error Class 2: Error class 2</p> <p>3 / Error Class 3: Error class 3</p> <p>Setting can only be modified if power stage is disabled.</p> <p>Modified settings become active the next time the power stage is enabled.</p> <p>Available with firmware version \geqV01.26.</p>	- 1 3 3	UINT16 R/W per. -	Modbus 1400
<i>ESIM_HighResolution</i>	<p>Encoder simulation: High resolution.</p> <p>Specifies the number of increments per revolution with 12 bit decimal places. If the parameter is set to a multiple of 4096, the index pulse will be generated exactly at the same position within one revolution.</p> <p>The setting of parameter <i>ESIM_scale</i> is only used if parameter <i>ESIM_HighResolution</i> is set to 0. Otherwise, the setting of <i>ESIM_HighResolution</i> is used.</p> <p>Example: 1417.322835 encoder simulation pulses per revolution are required.</p> <p>Set the parameter to $1417.322835 * 4096 = 5805354$.</p> <p>In this example, the index pulse will be generated exactly after every 1417 pulses. This means that the index pulse shifts with each revolution.</p> <p>Setting can only be modified if power stage is disabled.</p> <p>Modified settings become active the next time the product is powered on.</p>	Enclnc 0 0 268431360	UINT32 R/W per. expert	Modbus 1380

Parameter name HMI menu HMI name	Description	Unit Minimum value Factory setting Maximum value	Data type R/W Persistent Expert	Parameter address via fieldbus
<i>ESIM_PhaseShift</i>	Encoder simulation: Phase shift for pulse output. The generated encoder simulation pulses can be shifted in units of 1/4096 encoder pulses. The shift results in a position offset at PTO. The index pulse is shifted as well. Modified settings become active immediately. Available with firmware version \geq V01.10.	- -32768 0 32767	INT16 R/W - expert	Modbus 1382
<i>ESIM_scale</i> <i>C o n F → i - o -</i> <i>E S S C</i>	Resolution of encoder simulation. Resolution defines the number of increments per revolution (AB signal with quadruple evaluation). The index pulse is created once per revolution at an interval where signal A and signal B are high. Setting can only be modified if power stage is disabled. Modified settings become active the next time the product is powered on.	Enclnc 8 4096 65535	UINT16 R/W per. -	Modbus 1322
<i>GEARdenom</i>	Denominator of gear ratio. See description GEARnum	- 1 1 2147483647	INT32 R/W per. -	Modbus 9734
<i>GEARdenom2</i>	Denominator of gear ratio number 2. See description GEARnum	- 1 1 2147483647	INT32 R/W per. -	Modbus 9752
<i>GEARdir_enabl</i>	Enabled direction of movement for operating mode Electronic Gear. 1 / Positive: Positive direction 2 / Negative: Negative direction 3 / Both: Both directions This allows you to activate a return movement lock function. Modified settings become active immediately.	- 1 3 3	UINT16 R/W per. -	Modbus 9738
<i>GEARjerklim</i> <i>C o n F → i - o -</i> <i>G F i L</i>	Activation of jerk limitation. 0 / Off / o F F: Jerk limitation deactivated. 1 / PosSyncOn / P _ o n: Jerk limitation active (only with position synchronization). The time for jerk limitation must be set via parameter RAMP_v_jerk. Setting can only be modified if power stage is disabled. Modified settings become active immediately. Available with firmware version \geq V01.02.	- 0 0 1	UINT16 R/W per. -	Modbus 9742

Parameter name HMI menu HMI name	Description	Unit Minimum value Factory setting Maximum value	Data type R/W Persistent Expert	Parameter address via fieldbus
<i>GEARnum</i>	Numerator of gear ratio. GEARnum ----- = Gear ratio GEARdenom The new gear ratio is applied when the numerator value is supplied. Modified settings become active immediately.	- -2147483648 1 2147483647	INT32 R/W per. -	Modbus 9736
<i>GEARnum2</i>	Numerator of gear ratio number 2. GEARnum2 ----- = Gear ratio GEARdenom2 The new gear ratio is applied when the numerator value is supplied. Modified settings become active immediately.	- -2147483648 1 2147483647	INT32 R/W per. -	Modbus 9754
<i>GEARpos_v_max</i>	Velocity limitation for the method Position Synchronization. Value 0: No velocity limitation Value >0: Velocity limitation in usr_v Modified settings become active immediately. Available with firmware version ≥V01.10.	usr_v 0 0 2147483647	UINT32 R/W per. -	Modbus 9746
<i>GEARposChgMode</i>	Treatment of position changes with inactive power stage. 0 / Off: Position changes in states with disabled power stage are ignored. 1 / On: Position changes in states with disabled power stage are taken into account. This setting has an effect only if gear processing is started in the mode 'Synchronization with compensation movement'. Modified settings become active the next time the power stage is enabled.	- 0 0 1	UINT16 R/W per. -	Modbus 9750

Parameter name HMI menu HMI name	Description	Unit Minimum value Factory setting Maximum value	Data type R/W Persistent Expert	Parameter address via fieldbus
<i>GEARratio</i> <i>ConF → r - o -</i> <i>GFRC</i>	Selection of gear ratio. 0 / Gear Factor / FRC : Usage of gear ratio adjusted with GEARnum/GEARdenom 1 / 200 / 200 : 200 2 / 400 / 400 : 400 3 / 500 / 500 : 500 4 / 1000 / 1000 : 1000 5 / 2000 / 2000 : 2000 6 / 4000 / 4000 : 4000 7 / 5000 / 5000 : 5000 8 / 10000 / 10000 : 10000 9 / 4096 / 4096 : 4096 10 / 8192 / 8192 : 8192 11 / 16384 / 16384 : 16384 A change of the reference value by the specified value causes one motor revolution. Modified settings become active immediately.	- 0 0 11	UINT16 R/W per. -	Modbus 9740
<i>HMIDispPara</i> <i>non</i> <i>SupV</i>	HMI display when motor moves. 0 / OperatingState / SEL : Operating state 1 / v_act / VRC : Actual motor velocity 2 / I_act / IRC : Actual motor current Modified settings become active immediately.	- 0 0 2	UINT16 R/W per. -	Modbus 14852
<i>HMIlocked</i>	Lock HMI. 0 / Not Locked / nLoC : HMI not locked 1 / Locked / LoC : HMI locked The following functions can no longer be started when the HMI is locked: - Parameter change - Jog - Autotuning - Fault Reset Modified settings become active immediately.	- 0 0 1	UINT16 R/W per. -	Modbus 14850
<i>InvertDirOfCount</i>	Inversion of direction of counting at PTI interface. 0 / Inversion Off : Inversion of direction of counting is off 1 / Inversion On : Inversion of direction of counting is on Modified settings become active immediately.	- 0 0 1	UINT16 R/W per. -	Modbus 2062

Parameter name HMI menu HMI name	Description	Unit Minimum value Factory setting Maximum value	Data type R/W Persistent Expert	Parameter address via fieldbus
<i>InvertDirOfMove</i> C o n F → R C G - i n n o	Inversion of direction of movement. 0 / Inversion Off / o F F : Inversion of direction of movement is off 1 / Inversion On / o n : Inversion of direction of movement is on The limit switch which is reached with a movement in positive direction must be connected to the positive limit switch input and vice versa. Setting can only be modified if power stage is disabled. Modified settings become active the next time the product is powered on.	- 0 0 1	UINT16 R/W per. -	Modbus 1560
<i>IO_AutoEnable</i> C o n F → R C G - i o R E	Enabling the power stage at PowerOn. 0 / RisingEdge / r i S E : A rising edge with the signal input function "Enable" enables the power stage 1 / HighLevel / L E V L : An active signal input with signal input function "Enable" enables the power stage 2 / AutoOn / R u t o : The power stage is automatically enabled Modified settings become active the next time the power stage is enabled.	- 0 0 2	UINT16 R/W per. -	Modbus 1292
<i>IO_AutoEnaConfig</i> C o n F → R C G - i o E n	Enabling the power stage as set via IO_AutoEnable even after error. 0 / Off / o F F : Setting in parameter IO_AutoEnable is only used after start-up 1 / On / o n : Setting in parameter IO_AutoEnable is used after start-up and after detected error Modified settings become active the next time the power stage is enabled.	- 0 0 1	UINT16 R/W per. -	Modbus 1288
<i>IO_FaultResOnEnalnp</i> C o n F → R C G - i E F r	Additional 'Fault Reset' for the signal input function 'Enable'. 0 / Off / o F F : No additional 'Fault Reset' 1 / OnFallingEdge / F F L L : Additional 'Fault Reset' with falling edge 2 / OnRisingEdge / r i S E : Additional 'Fault Reset' with rising edge Modified settings become active the next time the power stage is enabled. Available with firmware version ≥V01.12.	- 0 0 2	UINT16 R/W per. -	Modbus 1384
<i>IO_GEARmethod</i> C o n F → R C G - i o G n	Processing mode for operating mode Electronic Gear. 1 / Position Synchronization Immediate / P o i n : Position synchronization without compensation movement 2 / Position Synchronization Compensated / P o c o : Position synchronization with compensation movement 3 / Velocity Synchronization / V E L o : Velocity synchronization Modified settings become active the next time the motor moves.	- 1 1 3	UINT16 R/W per. -	Modbus 1326

Parameter name HMI menu HMI name	Description	Unit Minimum value Factory setting Maximum value	Data type R/W Persistent Expert	Parameter address via fieldbus
<i>IO_l_limit</i> C o n F → I - 0 - I L I Π	Current limitation via input. A current limit can be activated via a digital input. In increments of 0.01 A _{rms} . Modified settings become active immediately.	A _{rms} 0.00 0.20 300.00	UINT16 R/W per. -	Modbus 1614
<i>IO_JOGmethod</i> C o n F → R C G - I o J G	Selection of jog method. 0 / Continuous Movement / c o Π o : Jog with continuous movement 1 / Step Movement / S E Π o : Jog with step movement Modified settings become active the next time the motor moves.	- 0 0 1	UINT16 R/W per. -	Modbus 1328
<i>IO_ModeSwitch</i> C o n F → R C G - I o Π S	Operating mode for signal input function Operating Mode Switch. 0 / None / n o n E : None 1 / Profile Torque / E o r 9 : Profile Torque 2 / Profile Velocity / V E L P : Profile Velocity 3 / Electronic Gear / G E R r : Electronic Gear Modified settings become active immediately.	- 0 0 3	UINT16 R/W per. -	Modbus 1630
<i>IO_PTtq_reference</i> C o n F → R C G - I o E 9	Reference value source for operating mode Profile Torque. 0 / Analog Input / I R n R : Reference value via analog input 1 / PTI Interface / I P E I : Reference value via PTI interface Setting can only be modified if power stage is disabled. Modified settings become active the next time the power stage is enabled. Available with firmware version ≥V01.20.	- 0 0 1	UINT16 R/W per. -	Modbus 1392
<i>IO_v_limit</i>	Velocity limitation via input. A velocity limitation can be activated via a digital input. In operating mode Profile Torque, the minimum velocity is internally limited to 100 RPM. Modified settings become active immediately.	usr_v 0 10 2147483647	UINT32 R/W per. -	Modbus 1596
<i>IOdefaultMode</i> C o n F → R C G - I o - Π	Operating mode. 0 / None / n o n E : None 1 / Profile Torque / E o r 9 : Profile Torque 2 / Profile Velocity / V E L P : Profile Velocity 3 / Electronic Gear / G E R r : Electronic Gear 5 / Jog / J o G : Jog Setting can only be modified if power stage is disabled. Modified settings become active the next time the product is powered on.	- 0 5 5	UINT16 R/W per. -	Modbus 1286

Parameter name HMI menu HMI name	Description	Unit Minimum value Factory setting Maximum value	Data type R/W Persistent Expert	Parameter address via fieldbus
<i>IOfunct_DI0</i> <i>CONF → I - 0 -</i> <i>DI0</i>	<p>Function Input DI0.</p> <p>1 / Freely Available / NONE: Available as required</p> <p>2 / Fault Reset / FRES: Fault reset after error</p> <p>3 / Enable / ENAB: Enables the power stage</p> <p>4 / Halt / HALT: Halt</p> <p>6 / Current Limitation / ILI: Limits the current to parameter value</p> <p>7 / Zero Clamp / CLIP: Zero clamping</p> <p>8 / Velocity Limitation / VLI: Limits the velocity to parameter value</p> <p>9 / Jog Positive / JOG P: Jog: Moves in positive direction</p> <p>10 / Jog Negative / JOG N: Jog: Moves in negative direction</p> <p>11 / Jog Fast/Slow / JOG F: Jog: Switches between slow and fast movement</p> <p>12 / Gear Ratio Switch / GRAT: Electronic Gear: Switches between two gear ratios</p> <p>19 / Gear Offset 1 / GOF 1: Electronic Gear: Adds first gear offset</p> <p>20 / Gear Offset 2 / GOF 2: Electronic Gear: Adds second gear offset</p> <p>21 / Reference Switch (REF) / REF: Reference switch</p> <p>22 / Positive Limit Switch (LIMP) / LIP: Positive limit switch</p> <p>23 / Negative Limit Switch (LIMN) / LIN: Negative limit switch</p> <p>24 / Switch Controller Parameter Set / SCPR: Switches control loop parameter set</p> <p>25 / Inversion AI1 / AI1V: Inverts analog input AI1</p> <p>26 / Inversion AI2 / AI2V: Inverts analog input AI2</p> <p>27 / Operating Mode Switch / OSW: Switches operating mode</p> <p>28 / Velocity Controller Integral Off / ENOF: Switches off velocity controller integral term</p> <p>30 / Start Signal Of RMAC / SRPC: Start signal of relative movement after capture (RMAC)</p> <p>31 / Activate RMAC / ARPC: Activates the relative movement after capture (RMAC)</p> <p>32 / Activate Operating Mode / AOP: Activates operating mode</p> <p>40 / Release Holding Brake / REHB: Releases the holding brake</p> <p>Setting can only be modified if power stage is disabled.</p> <p>Modified settings become active the next time the product is powered on.</p>	- - - -	UINT16 R/W per. -	Modbus 1794
<i>IOfunct_DI1</i>	Function Input DI1.	-	UINT16	Modbus 1796

Parameter name HMI menu HMI name	Description	Unit Minimum value Factory setting Maximum value	Data type R/W Persistent Expert	Parameter address via fieldbus
<i>CONF</i> → <i>1-0-0- d,1</i>	<p>1 / Freely Available / <i>nonE</i>: Available as required</p> <p>2 / Fault Reset / <i>FRES</i>: Fault reset after error</p> <p>3 / Enable / <i>ENAB</i>: Enables the power stage</p> <p>4 / Halt / <i>HALT</i>: Halt</p> <p>6 / Current Limitation / <i>ILN</i>: Limits the current to parameter value</p> <p>7 / Zero Clamp / <i>CLNP</i>: Zero clamping</p> <p>8 / Velocity Limitation / <i>VLN</i>: Limits the velocity to parameter value</p> <p>9 / Jog Positive / <i>JOGP</i>: Jog: Moves in positive direction</p> <p>10 / Jog Negative / <i>JOGN</i>: Jog: Moves in negative direction</p> <p>11 / Jog Fast/Slow / <i>JOGF</i>: Jog: Switches between slow and fast movement</p> <p>12 / Gear Ratio Switch / <i>GRAT</i>: Electronic Gear: Switches between two gear ratios</p> <p>19 / Gear Offset 1 / <i>GOF1</i>: Electronic Gear: Adds first gear offset</p> <p>20 / Gear Offset 2 / <i>GOF2</i>: Electronic Gear: Adds second gear offset</p> <p>21 / Reference Switch (REF) / <i>REF</i>: Reference switch</p> <p>22 / Positive Limit Switch (LIMP) / <i>LNP</i>: Positive limit switch</p> <p>23 / Negative Limit Switch (LIMN) / <i>LNN</i>: Negative limit switch</p> <p>24 / Switch Controller Parameter Set / <i>CPAR</i>: Switches control loop parameter set</p> <p>25 / Inversion AI1 / <i>RA1V</i>: Inverts analog input AI1</p> <p>26 / Inversion AI2 / <i>RA2V</i>: Inverts analog input AI2</p> <p>27 / Operating Mode Switch / <i>NSW</i>: Switches operating mode</p> <p>28 / Velocity Controller Integral Off / <i>ENOF</i>: Switches off velocity controller integral term</p> <p>30 / Start Signal Of RMAC / <i>SRNC</i>: Start signal of relative movement after capture (RMAC)</p> <p>31 / Activate RMAC / <i>ARNC</i>: Activates the relative movement after capture (RMAC)</p> <p>32 / Activate Operating Mode / <i>RCOP</i>: Activates operating mode</p> <p>40 / Release Holding Brake / <i>REHB</i>: Releases the holding brake</p> <p>Setting can only be modified if power stage is disabled.</p> <p>Modified settings become active the next time the product is powered on.</p>	- - -	R/W per. -	
<i>IOfunct_DI2</i> <i>CONF</i> → <i>1-0-0-</i>	Function Input DI2.	- -	UINT16 R/W	Modbus 1798

Parameter name HMI menu HMI name	Description	Unit Minimum value Factory setting Maximum value	Data type R/W Persistent Expert	Parameter address via fieldbus
<i>d 12</i>	<p>1 / Freely Available / n o n E: Available as required</p> <p>2 / Fault Reset / F r E S: Fault reset after error</p> <p>3 / Enable / E n A b: Enables the power stage</p> <p>4 / Halt / h A L t: Halt</p> <p>6 / Current Limitation / i L i P: Limits the current to parameter value</p> <p>7 / Zero Clamp / C L P P: Zero clamping</p> <p>8 / Velocity Limitation / V L i P: Limits the velocity to parameter value</p> <p>9 / Jog Positive / J o G P: Jog: Moves in positive direction</p> <p>10 / Jog Negative / J o G n: Jog: Moves in negative direction</p> <p>11 / Jog Fast/Slow / J o G F: Jog: Switches between slow and fast movement</p> <p>12 / Gear Ratio Switch / G r A t: Electronic Gear: Switches between two gear ratios</p> <p>19 / Gear Offset 1 / G o F 1: Electronic Gear: Adds first gear offset</p> <p>20 / Gear Offset 2 / G o F 2: Electronic Gear: Adds second gear offset</p> <p>21 / Reference Switch (REF) / r E F: Reference switch</p> <p>22 / Positive Limit Switch (LIMP) / L i P P: Positive limit switch</p> <p>23 / Negative Limit Switch (LIMN) / L i P n: Negative limit switch</p> <p>24 / Switch Controller Parameter Set / C P A r: Switches control loop parameter set</p> <p>25 / Inversion AI1 / A I 1 V: Inverts analog input AI1</p> <p>26 / Inversion AI2 / A I 2 V: Inverts analog input AI2</p> <p>27 / Operating Mode Switch / P S W t: Switches operating mode</p> <p>28 / Velocity Controller Integral Off / E n o F: Switches off velocity controller integral term</p> <p>30 / Start Signal Of RMAC / S r P c: Start signal of relative movement after capture (RMAC)</p> <p>31 / Activate RMAC / A r P c: Activates the relative movement after capture (RMAC)</p> <p>32 / Activate Operating Mode / A c o P: Activates operating mode</p> <p>40 / Release Holding Brake / r E h b: Releases the holding brake</p> <p>Setting can only be modified if power stage is disabled.</p> <p>Modified settings become active the next time the product is powered on.</p>	- - - -	per. -	
<i>IOfunct_DI3</i> <i>C o n F → i - o -</i>	Function Input DI3.	- -	UINT16 R/W	Modbus 1800

Parameter name HMI menu HMI name	Description	Unit Minimum value Factory setting Maximum value	Data type R/W Persistent Expert	Parameter address via fieldbus
d, 3	<p>1 / Freely Available / n o n E: Available as required</p> <p>2 / Fault Reset / F r E S: Fault reset after error</p> <p>3 / Enable / E n A b: Enables the power stage</p> <p>4 / Halt / h A L T: Halt</p> <p>6 / Current Limitation / , L , n: Limits the current to parameter value</p> <p>7 / Zero Clamp / C L n P: Zero clamping</p> <p>8 / Velocity Limitation / V L , n: Limits the velocity to parameter value</p> <p>9 / Jog Positive / J o G P: Jog: Moves in positive direction</p> <p>10 / Jog Negative / J o G n: Jog: Moves in negative direction</p> <p>11 / Jog Fast/Slow / J o G F: Jog: Switches between slow and fast movement</p> <p>12 / Gear Ratio Switch / G r A T: Electronic Gear: Switches between two gear ratios</p> <p>19 / Gear Offset 1 / G o F 1: Electronic Gear: Adds first gear offset</p> <p>20 / Gear Offset 2 / G o F 2: Electronic Gear: Adds second gear offset</p> <p>21 / Reference Switch (REF) / r E F: Reference switch</p> <p>22 / Positive Limit Switch (LIMP) / L , n P: Positive limit switch</p> <p>23 / Negative Limit Switch (LIMN) / L , n n: Negative limit switch</p> <p>24 / Switch Controller Parameter Set / C P A r: Switches control loop parameter set</p> <p>25 / Inversion AI1 / R I , V: Inverts analog input AI1</p> <p>26 / Inversion AI2 / R 2 , V: Inverts analog input AI2</p> <p>27 / Operating Mode Switch / n S W T: Switches operating mode</p> <p>28 / Velocity Controller Integral Off / E n o F: Switches off velocity controller integral term</p> <p>30 / Start Signal Of RMAC / S r n C: Start signal of relative movement after capture (RMAC)</p> <p>31 / Activate RMAC / R r n C: Activates the relative movement after capture (RMAC)</p> <p>32 / Activate Operating Mode / R c o P: Activates operating mode</p> <p>40 / Release Holding Brake / r E h b: Releases the holding brake</p> <p>Setting can only be modified if power stage is disabled.</p> <p>Modified settings become active the next time the product is powered on.</p>	- - - -	per. -	
IOfuncn_DI4 [o n F → , - o -	Function Input DI4.	- -	UINT16 R/W	Modbus 1802

Parameter name HMI menu HMI name	Description	Unit Minimum value Factory setting Maximum value	Data type R/W Persistent Expert	Parameter address via fieldbus
d14	<p>1 / Freely Available / n o n E: Available as required</p> <p>2 / Fault Reset / F r E S: Fault reset after error</p> <p>3 / Enable / E n A b: Enables the power stage</p> <p>4 / Halt / h A L T: Halt</p> <p>6 / Current Limitation / I L I P: Limits the current to parameter value</p> <p>7 / Zero Clamp / C L P P: Zero clamping</p> <p>8 / Velocity Limitation / V L I P: Limits the velocity to parameter value</p> <p>9 / Jog Positive / J o G P: Jog: Moves in positive direction</p> <p>10 / Jog Negative / J o G n: Jog: Moves in negative direction</p> <p>11 / Jog Fast/Slow / J o G F: Jog: Switches between slow and fast movement</p> <p>12 / Gear Ratio Switch / G r A T: Electronic Gear: Switches between two gear ratios</p> <p>19 / Gear Offset 1 / G o F 1: Electronic Gear: Adds first gear offset</p> <p>20 / Gear Offset 2 / G o F 2: Electronic Gear: Adds second gear offset</p> <p>21 / Reference Switch (REF) / r E F: Reference switch</p> <p>22 / Positive Limit Switch (LIMP) / L I P P: Positive limit switch</p> <p>23 / Negative Limit Switch (LIMN) / L I P n: Negative limit switch</p> <p>24 / Switch Controller Parameter Set / C P A r: Switches control loop parameter set</p> <p>25 / Inversion AI1 / A I 1 V: Inverts analog input AI1</p> <p>26 / Inversion AI2 / A I 2 V: Inverts analog input AI2</p> <p>27 / Operating Mode Switch / P S W E: Switches operating mode</p> <p>28 / Velocity Controller Integral Off / E n o F: Switches off velocity controller integral term</p> <p>30 / Start Signal Of RMAC / S r P c: Start signal of relative movement after capture (RMAC)</p> <p>31 / Activate RMAC / A r P c: Activates the relative movement after capture (RMAC)</p> <p>32 / Activate Operating Mode / A c o P: Activates operating mode</p> <p>40 / Release Holding Brake / r E h b: Releases the holding brake</p> <p>Setting can only be modified if power stage is disabled.</p> <p>Modified settings become active the next time the product is powered on.</p>	- - - -	per. -	
IOfunct_DI5 C o n F → i - o -	Function Input DI5.	- -	UINT16 R/W	Modbus 1804

Parameter name HMI menu HMI name	Description	Unit Minimum value Factory setting Maximum value	Data type R/W Persistent Expert	Parameter address via fieldbus
<i>d, 5</i>	<p>1 / Freely Available / n o n E: Available as required</p> <p>2 / Fault Reset / F r E S: Fault reset after error</p> <p>3 / Enable / E n A b: Enables the power stage</p> <p>4 / Halt / h A L T: Halt</p> <p>6 / Current Limitation / , L , n: Limits the current to parameter value</p> <p>7 / Zero Clamp / C L n P: Zero clamping</p> <p>8 / Velocity Limitation / V L , n: Limits the velocity to parameter value</p> <p>9 / Jog Positive / J o G P: Jog: Moves in positive direction</p> <p>10 / Jog Negative / J o G n: Jog: Moves in negative direction</p> <p>11 / Jog Fast/Slow / J o G F: Jog: Switches between slow and fast movement</p> <p>12 / Gear Ratio Switch / G r A T: Electronic Gear: Switches between two gear ratios</p> <p>19 / Gear Offset 1 / G o F 1: Electronic Gear: Adds first gear offset</p> <p>20 / Gear Offset 2 / G o F 2: Electronic Gear: Adds second gear offset</p> <p>21 / Reference Switch (REF) / r E F: Reference switch</p> <p>22 / Positive Limit Switch (LIMP) / L , n P: Positive limit switch</p> <p>23 / Negative Limit Switch (LIMN) / L , n n: Negative limit switch</p> <p>24 / Switch Controller Parameter Set / C P A r: Switches control loop parameter set</p> <p>25 / Inversion AI1 / R I , V: Inverts analog input AI1</p> <p>26 / Inversion AI2 / R 2 , V: Inverts analog input AI2</p> <p>27 / Operating Mode Switch / n S W T: Switches operating mode</p> <p>28 / Velocity Controller Integral Off / E n o F: Switches off velocity controller integral term</p> <p>30 / Start Signal Of RMAC / S r n C: Start signal of relative movement after capture (RMAC)</p> <p>31 / Activate RMAC / A r n C: Activates the relative movement after capture (RMAC)</p> <p>32 / Activate Operating Mode / A c o P: Activates operating mode</p> <p>40 / Release Holding Brake / r E h b: Releases the holding brake</p> <p>Setting can only be modified if power stage is disabled.</p> <p>Modified settings become active the next time the product is powered on.</p>	- - - -	per. -	
<i>IOfunct_DQ0</i> <i>C o n F → , - o -</i>	Function Output DQ0.	- -	UINT16 R/W	Modbus 1810

Parameter name HMI menu HMI name	Description	Unit Minimum value Factory setting Maximum value	Data type R/W Persistent Expert	Parameter address via fieldbus
<i>d o 0</i>	<p>1 / Freely Available / n o n E: Available as required</p> <p>2 / No Fault / n F L E: Signals operating states Ready To Switch On, Switched On and Operation Enabled</p> <p>3 / Active / R e E r: Signals operating state Operation Enabled</p> <p>4 / RMAC Active Or Finished / r n e R: Relative movement after capture active or finished (RMAC)</p> <p>5 / In Position Deviation Window / i n - P: Position deviation is within window</p> <p>6 / In Velocity Deviation Window / i n - V: Velocity deviation is within window</p> <p>7 / Velocity Below Threshold / v e h r: Motor velocity below threshold</p> <p>8 / Current Below Threshold / i e h r: Motor current below threshold</p> <p>9 / Halt Acknowledge / h R L E: Halt acknowledgement</p> <p>13 / Motor Standstill / n s t d: Motor at a standstill</p> <p>14 / Selected Error / s e r r: One of the specified errors of error classes 1 ... 4 is active</p> <p>16 / Selected Warning / s w r n: One of the specified errors of error class 0 is active</p> <p>22 / Motor Moves Positive / n p o s: Motor moves in positive direction</p> <p>23 / Motor Moves Negative / n n e g: Motor moves in negative direction</p> <p>Setting can only be modified if power stage is disabled.</p> <p>Modified settings become active the next time the product is powered on.</p>	- -	per. -	
<p><i>IOfuncn_DQ1</i></p> <p><i>C o n F → i - o -</i></p> <p><i>d o 1</i></p>	<p>Function Output DQ1.</p> <p>1 / Freely Available / n o n E: Available as required</p> <p>2 / No Fault / n F L E: Signals operating states Ready To Switch On, Switched On and Operation Enabled</p> <p>3 / Active / R e E r: Signals operating state Operation Enabled</p> <p>4 / RMAC Active Or Finished / r n e R: Relative movement after capture active or finished (RMAC)</p> <p>5 / In Position Deviation Window / i n - P: Position deviation is within window</p> <p>6 / In Velocity Deviation Window / i n - V: Velocity deviation is within window</p> <p>7 / Velocity Below Threshold / v e h r: Motor velocity below threshold</p> <p>8 / Current Below Threshold / i e h r: Motor current below threshold</p> <p>9 / Halt Acknowledge / h R L E: Halt acknowledgement</p>	- - - -	UINT16 R/W per. -	Modbus 1812

Parameter name HMI menu HMI name	Description	Unit Minimum value Factory setting Maximum value	Data type R/W Persistent Expert	Parameter address via fieldbus
	<p>13 / Motor Standstill / $\Pi S E d$: Motor at a standstill</p> <p>14 / Selected Error / $S E r r$: One of the specified errors of error classes 1 ... 4 is active</p> <p>16 / Selected Warning / $S W r n$: One of the specified errors of error class 0 is active</p> <p>22 / Motor Moves Positive / $\Pi P o S$: Motor moves in positive direction</p> <p>23 / Motor Moves Negative / $\Pi n E G$: Motor moves in negative direction</p> <p>Setting can only be modified if power stage is disabled.</p> <p>Modified settings become active the next time the product is powered on.</p>			
<i>IOfunct_DQ2</i> <i>CONF → i - o -</i> <i>d o 2</i>	<p>Function Output DQ2.</p> <p>1 / Freely Available / $n o n E$: Available as required</p> <p>2 / No Fault / $n F L t$: Signals operating states Ready To Switch On, Switched On and Operation Enabled</p> <p>3 / Active / $R c t i$: Signals operating state Operation Enabled</p> <p>4 / RMAC Active Or Finished / $r \Pi c R$: Relative movement after capture active or finished (RMAC)</p> <p>5 / In Position Deviation Window / $i n - P$: Position deviation is within window</p> <p>6 / In Velocity Deviation Window / $i n - V$: Velocity deviation is within window</p> <p>7 / Velocity Below Threshold / $V t h r$: Motor velocity below threshold</p> <p>8 / Current Below Threshold / $i t h r$: Motor current below threshold</p> <p>9 / Halt Acknowledge / $h A L t$: Halt acknowledgement</p> <p>13 / Motor Standstill / $\Pi S E d$: Motor at a standstill</p> <p>14 / Selected Error / $S E r r$: One of the specified errors of error classes 1 ... 4 is active</p> <p>16 / Selected Warning / $S W r n$: One of the specified errors of error class 0 is active</p> <p>22 / Motor Moves Positive / $\Pi P o S$: Motor moves in positive direction</p> <p>23 / Motor Moves Negative / $\Pi n E G$: Motor moves in negative direction</p> <p>Setting can only be modified if power stage is disabled.</p> <p>Modified settings become active the next time the product is powered on.</p>	- - - -	UINT16 R/W per. -	Modbus 1814

Parameter name HMI menu HMI name	Description	Unit Minimum value Factory setting Maximum value	Data type R/W Persistent Expert	Parameter address via fieldbus
<i>IOfunct_DQ3</i> <i>CONF → i - o -</i> <i>d o 3</i>	<p>Function Output DQ3.</p> <p>1 / Freely Available / n o n E: Available as required</p> <p>2 / No Fault / n F L E: Signals operating states Ready To Switch On, Switched On and Operation Enabled</p> <p>3 / Active / R e E: Signals operating state Operation Enabled</p> <p>4 / RMAC Active Or Finished / r n e R: Relative movement after capture active or finished (RMAC)</p> <p>5 / In Position Deviation Window / i n - P: Position deviation is within window</p> <p>6 / In Velocity Deviation Window / i n - V: Velocity deviation is within window</p> <p>7 / Velocity Below Threshold / v e h r: Motor velocity below threshold</p> <p>8 / Current Below Threshold / i e h r: Motor current below threshold</p> <p>9 / Halt Acknowledge / h R L E: Halt acknowledgement</p> <p>13 / Motor Standstill / n S e d: Motor at a standstill</p> <p>14 / Selected Error / S E r r: One of the specified errors of error classes 1 ... 4 is active</p> <p>16 / Selected Warning / S W r n: One of the specified errors of error class 0 is active</p> <p>22 / Motor Moves Positive / n P o S: Motor moves in positive direction</p> <p>23 / Motor Moves Negative / n n E G: Motor moves in negative direction</p> <p>Setting can only be modified if power stage is disabled.</p> <p>Modified settings become active the next time the product is powered on.</p>	- - - -	UINT16 R/W per. -	Modbus 1816
<i>IOfunct_DQ4</i> <i>CONF → i - o -</i> <i>d o 4</i>	<p>Function Output DQ4.</p> <p>1 / Freely Available / n o n E: Available as required</p> <p>2 / No Fault / n F L E: Signals operating states Ready To Switch On, Switched On and Operation Enabled</p> <p>3 / Active / R e E: Signals operating state Operation Enabled</p> <p>4 / RMAC Active Or Finished / r n e R: Relative movement after capture active or finished (RMAC)</p> <p>5 / In Position Deviation Window / i n - P: Position deviation is within window</p> <p>6 / In Velocity Deviation Window / i n - V: Velocity deviation is within window</p> <p>7 / Velocity Below Threshold / v e h r: Motor velocity below threshold</p> <p>8 / Current Below Threshold / i e h r: Motor current below threshold</p>	- - - -	UINT16 R/W per. -	Modbus 1818

Parameter name HMI menu HMI name	Description	Unit Minimum value Factory setting Maximum value	Data type R/W Persistent Expert	Parameter address via fieldbus
	<p>9 / Halt Acknowledge / H A L T : Halt acknowledgement</p> <p>13 / Motor Standstill / M S T D : Motor at a standstill</p> <p>14 / Selected Error / S E R R : One of the specified errors of error classes 1 ... 4 is active</p> <p>16 / Selected Warning / S W R N : One of the specified errors of error class 0 is active</p> <p>22 / Motor Moves Positive / M P O S : Motor moves in positive direction</p> <p>23 / Motor Moves Negative / M N E G : Motor moves in negative direction</p> <p>Setting can only be modified if power stage is disabled.</p> <p>Modified settings become active the next time the product is powered on.</p>			
<i>IOsigCurrLim</i>	<p>Signal evaluation for signal input function Current Limitation.</p> <p>1 / Normally Closed: Normally closed NC</p> <p>2 / Normally Open: Normally open NO</p> <p>Setting can only be modified if power stage is disabled.</p> <p>Modified settings become active the next time the power stage is enabled.</p> <p>Available with firmware version $\geq V01.26$.</p>	<p>-</p> <p>1</p> <p>2</p> <p>2</p>	<p>UINT16</p> <p>R/W</p> <p>per.</p> <p>-</p>	Modbus 2128
<i>IOsigLIMN</i>	<p>Signal evaluation for negative limit switch.</p> <p>0 / Inactive: Inactive</p> <p>1 / Normally Closed: Normally closed NC</p> <p>2 / Normally Open: Normally open NO</p> <p>Setting can only be modified if power stage is disabled.</p> <p>Modified settings become active the next time the power stage is enabled.</p>	<p>-</p> <p>0</p> <p>1</p> <p>2</p>	<p>UINT16</p> <p>R/W</p> <p>per.</p> <p>-</p>	Modbus 1566
<i>IOsigLIMP</i>	<p>Signal evaluation for positive limit switch.</p> <p>0 / Inactive: Inactive</p> <p>1 / Normally Closed: Normally closed NC</p> <p>2 / Normally Open: Normally open NO</p> <p>Setting can only be modified if power stage is disabled.</p> <p>Modified settings become active the next time the power stage is enabled.</p>	<p>-</p> <p>0</p> <p>1</p> <p>2</p>	<p>UINT16</p> <p>R/W</p> <p>per.</p> <p>-</p>	Modbus 1568

Parameter name HMI menu HMI name	Description	Unit Minimum value Factory setting Maximum value	Data type R/W Persistent Expert	Parameter address via fieldbus
<i>IOsigREF</i>	Signal evaluation for reference switch. 1 / Normally Closed: Normally closed NC 2 / Normally Open: Normally open NO The reference switch is only active while a reference movement to the reference switch is processed. Setting can only be modified if power stage is disabled. Modified settings become active the next time the power stage is enabled.	- 1 1 2	UINT16 R/W per. -	Modbus 1564
<i>IOsigVelLim</i>	Signal evaluation for signal input function Velocity Limitation. 1 / Normally Closed: Normally closed NC 2 / Normally Open: Normally open NO Setting can only be modified if power stage is disabled. Modified settings become active the next time the power stage is enabled. Available with firmware version $\geq V01.26$.	- 1 2 2	UINT16 R/W per. -	Modbus 2126
<i>Iref_PTIFreqMax</i>	Reference current for operating mode Profile Torque via PTI interface. Reference current corresponding to 1.6 million increments per second at the PTI interface for operating mode Profile Torque. In increments of 0.01 A_{rms} . Modified settings become active immediately. Available with firmware version $\geq V01.20$.	A_{rms} 0.00 - 463.00	UINT16 R/W per. -	Modbus 8200
<i>JOGstep</i>	Distance for step movement. Modified settings become active the next time the motor moves.	usr_p 1 20 2147483647	INT32 R/W per. -	Modbus 10510
<i>JOGtime</i>	Wait time for step movement. Modified settings become active the next time the motor moves.	ms 1 500 32767	UINT16 R/W per. -	Modbus 10512
<i>JOGv_fast</i> o P → J o G - J G h i	Velocity for fast movement. The adjustable value is internally limited to the parameter setting in RAMP_v_max. Modified settings become active immediately.	usr_v 1 180 2147483647	UINT32 R/W per. -	Modbus 10506
<i>JOGv_slow</i> o P → J o G - J G L o	Velocity for slow movement. The adjustable value is internally limited to the parameter setting in RAMP_v_max. Modified settings become active immediately.	usr_v 1 60 2147483647	UINT32 R/W per. -	Modbus 10504

Parameter name HMI menu HMI name	Description	Unit Minimum value Factory setting Maximum value	Data type R/W Persistent Expert	Parameter address via fieldbus
<i>LIM_HaltReaction</i> <i>C o n F → R C G -</i> <i>h e y P</i>	<p>Halt option code.</p> <p>1 / Deceleration Ramp / d e c E: Deceleration ramp</p> <p>3 / Torque Ramp / t o r 9: Torque ramp</p> <p>Set the deceleration ramp with parameter RAMP_v_dec.</p> <p>Set the torque ramp with parameter LIM_I_maxHalt.</p> <p>If a deceleration ramp is already active, the parameter cannot be written.</p> <p>Modified settings become active immediately.</p>	- 1 1 3	INT16 R/W per. -	Modbus 1582
<i>LIM_I_maxHalt</i> <i>C o n F → R C G -</i> <i>h c u r</i>	<p>Current for Halt.</p> <p>This value is only limited by the minimum/maximum value range (no limitation of this value by motor/power stage).</p> <p>In the case of a Halt, the current limit (<i>_I_max_act</i>) is one of the following values (whichever is lowest):</p> <ul style="list-style-type: none"> - <i>LIM_I_maxHalt</i> - <i>_M_I_max</i> - <i>_PS_I_max</i> <p>Further current limitations caused by I2t monitoring are also taken into account during a Halt.</p> <p>Default: <i>_PS_I_max</i> at 8 kHz PWM frequency and 230/480 V mains voltage</p> <p>In increments of 0.01 A_{rms}.</p> <p>Modified settings become active immediately.</p>	A _{rms} - - -	UINT16 R/W per. -	Modbus 4380
<i>LIM_I_maxQSTP</i> <i>C o n F → F L t -</i> <i>9 c u r</i>	<p>Current for Quick Stop.</p> <p>This value is only limited by the minimum/maximum value range (no limitation of this value by motor/power stage).</p> <p>In the case of a Quick Stop, the current limit (<i>_I_max_act</i>) is one of the following values (whichever is lowest):</p> <ul style="list-style-type: none"> - <i>LIM_I_maxQSTP</i> - <i>_M_I_max</i> - <i>_PS_I_max</i> <p>Further current limitations caused by I2t monitoring are also taken into account during a Quick Stop.</p> <p>Default: <i>_PS_I_max</i> at 8 kHz PWM frequency and 230/480 V mains voltage</p> <p>In increments of 0.01 A_{rms}.</p> <p>Modified settings become active immediately.</p>	A _{rms} - - -	UINT16 R/W per. -	Modbus 4378

Parameter name HMI menu HMI name	Description	Unit Minimum value Factory setting Maximum value	Data type R/W Persistent Expert	Parameter address via fieldbus
<i>LIM_QStopReact</i> <i>CONF → FLT -</i> <i>QSTP</i>	Quick Stop option code. 6 / Deceleration ramp (Quick Stop) / DEC : Use deceleration ramp and remain in operating state 7 Quick Stop 7 / Torque ramp (Quick Stop) / TOR : Use torque ramp and remain in operating state 7 Quick Stop Type of deceleration for Quick Stop. Setting of deceleration ramp with parameter RAMPquickstop. Setting of torque ramp with parameter LIM_I_maxQSTP. If a deceleration ramp is already active, the parameter cannot be written. Modified settings become active immediately.	- 6 6 7	INT16 R/W per. -	Modbus 1584
<i>Mains_reactor</i>	Mains reactor. 0 / No : No 1 / Yes : Yes Value 0: No mains reactor connected. The nominal power of the power stage is reduced. Value 1: A mains reactor is connected. Setting can only be modified if power stage is disabled. Modified settings become active immediately.	- 0 0 1	UINT16 R/W per. -	Modbus 1344
<i>MBaddress</i> <i>CONF → CON -</i> <i>MBAD</i>	Modbus address. Valid addresses: 1 to 247 Modified settings become active the next time the product is powered on.	- 1 1 247	UINT16 R/W per. -	Modbus 5640
<i>MBbaud</i> <i>CONF → CON -</i> <i>MBBD</i>	Modbus baud rate. 9600 / 9600 Baud / 9.6 : 9600 Baud 19200 / 19200 Baud / 19.2 : 19200 Baud 38400 / 38400 Baud / 38.4 : 38400 Baud Modified settings become active the next time the product is powered on.	- 9600 19200 38400	UINT32 R/W per. -	Modbus 5638
<i>MON_ChkTime</i> <i>CONF → I - O -</i> <i>CHKR</i>	Monitoring of time window. Adjustment of a time for monitoring of position deviation, velocity deviation, velocity value and current value. If the monitored value is in the permissible range during the adjusted time, the monitoring function delivers a positive result. The status can be output via a parameterizable output. Modified settings become active immediately.	ms 0 0 9999	UINT16 R/W per. -	Modbus 1594

Parameter name	Description	Unit	Data type	Parameter address via fieldbus
HMI menu		Minimum value	R/W	
HMI name		Factory setting	Persistent	
		Maximum value	Expert	
<i>MON_commutat</i>	Commutation monitoring. 0 / Off: Commutation monitoring off 1 / On: Commutation monitoring on in operating states 6, 7 and 8 2 / On (OpState6+7): Commutation monitoring on in operating states 6 and 7 Setting can only be modified if power stage is disabled. Modified settings become active the next time the power stage is enabled.	- 0 1 2	UINT16 R/W per. -	Modbus 1290
<i>MON_ConfModification</i>	Configuration modification monitoring. Value 0: Modification detected for each write access. Value 1: Modification detected for each write access which modifies a value. Value 2: Identical to value 0 if commissioning software is not connected. Identical to value 1 if commissioning software is connected. Modified settings become active immediately. Available with firmware version \geq V01.26.	- 0 2 2	UINT16 R/W per. -	Modbus 1082
<i>MON_DCbusVdcThresh</i>	DC bus overvoltage monitoring threshold. 0 / Reduction Off: Reduction is off 1 / Reduction On: Reduction is on This parameter is used to reduce the threshold for DC bus overvoltage monitoring. The parameter only affects single-phase devices supplied with 115 V and three-phase devices supplied with 208 V. Value 0: Single-phase: 450 Vdc Three-phase: 820 Vdc Value 1: Single-phase: 260 Vdc Three-phase: 450 Vdc Setting can only be modified if power stage is disabled. Modified settings become active the next time the power stage is enabled. Available with firmware version \geq V01.26.	- 0 0 1	UINT16 R/W per. -	Modbus 1402
<i>MON_ENC_Ampl</i>	Activation of monitoring of SinCos amplitude. Value 0: Deactivate monitoring Value 1: Activate monitoring Modified settings become active immediately. Available with firmware version \geq V01.26.	- 0 0 1	UINT16 R/W - -	Modbus 16322

Parameter name HMI menu HMI name	Description	Unit Minimum value Factory setting Maximum value	Data type R/W Persistent Expert	Parameter address via fieldbus
<i>MON_GroundFault</i>	Ground monitoring. 0 / Off: Ground monitoring off 1 / On: Ground monitoring on Modified settings become active the next time the product is powered on.	- 0 1 1	UINT16 R/W per. expert	Modbus 1312
<i>MON_I_Threshold</i> <i>[on F → , - 0 -</i> <i>, k h r</i>	Monitoring of current threshold. The system monitors whether the drive is below the defined value during the period set with <i>MON_ChkTime</i> . The status can be output via a parameterizable output. The parameter <i>_Iq_act_rms</i> is used as comparison value. In increments of 0.01 A_{rms} . Modified settings become active immediately.	A_{rms} 0.00 0.20 300.00	UINT16 R/W per. -	Modbus 1592
<i>MON_IO_SelErr1</i>	Signal output function Selected Error (error classes 1 to 4): First error code. This parameter specifies the error code of an error of error classes 1 ... 4 which is to activate the signal output function. Modified settings become active immediately.	- 0 0 65535	UINT16 R/W per. -	Modbus 15116
<i>MON_IO_SelErr2</i>	Signal output function Selected Error (error classes 1 to 4): Second error code. This parameter specifies the error code of an error of error classes 1 ... 4 which is to activate the signal output function. Modified settings become active immediately.	- 0 0 65535	UINT16 R/W per. -	Modbus 15118
<i>MON_IO_SelWar1</i>	Signal output function Selected Warning (error class 0): First error code. This parameter specifies the error code of an error of error class 0 which is to activate the signal output function. Modified settings become active immediately.	- 0 0 65535	UINT16 R/W per. -	Modbus 15120
<i>MON_IO_SelWar2</i>	Signal output function Selected Warning (error class 0): Second error code. This parameter specifies the error code of an error of error class 0 which is to activate the signal output function. Modified settings become active immediately.	- 0 0 65535	UINT16 R/W per. -	Modbus 15122

Parameter name	Description	Unit	Data type	Parameter address via fieldbus
HMI menu		Minimum value	R/W	
HMI name		Factory setting	Persistent	
		Maximum value	Expert	
<i>MON_MainsVolt</i>	<p>Detection and monitoring of mains phases.</p> <p>0 / Automatic Mains Detection: Automatic detection and monitoring of mains voltage</p> <p>1 / DC-Bus Only (Mains 1~230 V / 3~480 V): DC bus supply only, corresponding to mains voltage 230 V (single-phase) or 480 V (three phases)</p> <p>2 / DC-Bus Only (Mains 1~115 V / 3~208 V): DC bus supply only, corresponding to mains voltage 115 V (single-phase) or 208 V (three phases)</p> <p>3 / Mains 1~230 V / 3~480 V: Mains voltage 230 V (single-phase) or 480 V (three phases)</p> <p>4 / Mains 1~115 V / 3~208 V: Mains voltage 115 V (single-phase) or 208 V (three phases)</p> <p>5 / Reserved: Reserved</p> <p>Value 0: As soon as mains voltage detected, the device automatically verifies whether the mains voltage is 115 V or 230 V in the case of single-phase devices or 208 V or 400/480 V in the case of three-phase devices.</p> <p>Values 1 ... 2: If the device is supplied only via the DC bus, the parameter has to be set to the voltage value corresponding to the mains voltage of the supplying device. There is no mains voltage monitoring.</p> <p>Values 3 ... 4: If the mains voltage is not detected properly during start-up, the mains voltage to be used can be selected manually.</p> <p>Setting can only be modified if power stage is disabled.</p> <p>Modified settings become active the next time the power stage is enabled.</p>	- 0 0 5	UINT16 R/W per. expert	Modbus 1310
<i>MON_MotOvLoadOvTemp</i>	<p>Motor overload and overtemperature monitoring.</p> <p>Value 0: Motor overload and overtemperature monitoring using thermal retention and speed sensitivity (as per IEC 61800-5-1:2007/AMD1:2016)</p> <p>Value 1: Motor overload and overtemperature monitoring using the nominal stall torque of the motor, without thermal retention and speed sensitivity. Additional external measures may have to be implemented.</p> <p>Setting can only be modified if power stage is disabled.</p> <p>Modified settings become active immediately.</p> <p>Available with firmware version \geqV01.32.</p>	- 0 0 1	UINT16 R/W per. expert	Modbus 16336
<i>MON_p_dif_load</i>	<p>Maximum load-dependent position deviation.</p> <p>The load-dependent position deviation is the difference between the reference position and the actual position caused by the load.</p> <p>The parameter <i>MON_p_dif_load_usr</i> allows you to enter the value in user-defined units.</p> <p>In increments of 0.0001 revolution.</p> <p>Modified settings become active immediately.</p>	revolution 0.0001 1.0000 200.0000	UINT32 R/W per. -	Modbus 1606

Parameter name HMI menu HMI name	Description	Unit Minimum value Factory setting Maximum value	Data type R/W Persistent Expert	Parameter address via fieldbus
<i>MON_p_dif_load_usr</i>	<p>Maximum load-dependent position deviation.</p> <p>The load-dependent position deviation is the difference between the reference position and the actual position caused by the load.</p> <p>The minimum value, the factory setting and the maximum value depend on the scaling factor.</p> <p>Modified settings become active immediately.</p> <p>Available with firmware version \geqV01.05.</p>	usr_p 1 16384 2147483647	INT32 R/W per. -	Modbus 1660
<i>MON_p_dif_warn</i>	<p>Advisory limit of the load-dependent position deviation (error class 0).</p> <p>100.0 % correspond to the maximum position deviation (following error) as specified by means of parameter <i>MON_p_dif_load</i>.</p> <p>Modified settings become active immediately.</p>	% 0 75 100	UINT16 R/W per. -	Modbus 1618
<i>MON_p_DiffWin</i>	<p>Monitoring of position deviation.</p> <p>The system verifies whether the drive is within the defined deviation during the period set with <i>MON_ChkTime</i>.</p> <p>The status can be output via a parameterizable output.</p> <p>The parameter <i>MON_p_DiffWin_usr</i> allows you to enter the value in user-defined units.</p> <p>In increments of 0.0001 revolution.</p> <p>Modified settings become active immediately.</p>	revolution 0.0000 0.0010 0.9999	UINT16 R/W per. -	Modbus 1586
<i>MON_p_DiffWin_usr</i>	<p>Monitoring of position deviation.</p> <p>The system verifies whether the drive is within the defined deviation during the period set with <i>MON_ChkTime</i>.</p> <p>The status can be output via a parameterizable output.</p> <p>The minimum value, the factory setting and the maximum value depend on the scaling factor.</p> <p>Modified settings become active immediately.</p> <p>Available with firmware version \geqV01.05.</p>	usr_p 0 16 2147483647	INT32 R/W per. -	Modbus 1662
<i>MON_p_win</i>	<p>Standstill window, permissible control deviation.</p> <p>The control deviation for the standstill window time must be within this range for a standstill of the drive to be detected.</p> <p>Processing of the standstill window must be activated via the parameter <i>MON_p_winTime</i>.</p> <p>The parameter <i>MON_p_win_usr</i> allows you to enter the value in user-defined units.</p> <p>In increments of 0.0001 revolution.</p> <p>Modified settings become active immediately.</p>	revolution 0.0000 0.0010 3.2767	UINT16 R/W per. -	Modbus 1608

Parameter name HMI menu HMI name	Description	Unit Minimum value Factory setting Maximum value	Data type R/W Persistent Expert	Parameter address via fieldbus
<i>MON_p_win_usr</i>	Standstill window, permissible control deviation. The control deviation for the standstill window time must be within this range for a standstill of the drive to be detected. Processing of the standstill window must be activated via the parameter <i>MON_p_winTime</i> . The minimum value, the factory setting and the maximum value depend on the scaling factor. Modified settings become active immediately. Available with firmware version $\geq V01.05$.	usr_p 0 16 2147483647	INT32 R/W per. -	Modbus 1664
<i>MON_p_winTime</i>	Standstill window, time. Value 0: Monitoring of standstill window deactivated Value >0: Time in ms during which the control deviation must be in the standstill window Modified settings become active immediately.	ms 0 0 32767	UINT16 R/W per. -	Modbus 1610
<i>MON_p_winTout</i>	Timeout time for standstill window monitoring. Value 0: Timeout monitoring deactivated Value >0: Timeout time in ms Standstill window processing values are set via <i>MON_p_win</i> and <i>MON_p_winTime</i> . Time monitoring starts when the target position (reference position of position controller) is reached or when the profile generator has finished processing. Modified settings become active immediately.	ms 0 0 16000	UINT16 R/W per. -	Modbus 1612
<i>MON_SW_Limits</i>	Activation of software limit switches. 0 / None: Deactivated 1 / SWLIMP: Activation of software limit switches positive direction 2 / SWLIMN: Activation of software limit switches negative direction 3 / SWLIMP+SWLIMN: Activation of software limit switches both directions Software limit switches can only be activated if the zero point is valid. Modified settings become active immediately.	- 0 0 3	UINT16 R/W per. -	Modbus 1542
<i>MON_SWLimMode</i>	Behavior when position limit is reached. 0 / Standstill Behind Position Limit: Quick Stop is triggered at position limit and standstill is reached behind position limit 1 / Standstill At Position Limit: Quick Stop is triggered in front of position limit and standstill is reached at position limit Modified settings become active immediately. Available with firmware version $\geq V01.16$.	- 0 0 1	UINT16 R/W per. -	Modbus 1678

Parameter name HMI menu HMI name	Description	Unit Minimum value Factory setting Maximum value	Data type R/W Persistent Expert	Parameter address via fieldbus
<i>MON_swLimN</i>	Negative position limit for software limit switch. See description 'MON_swLimP'. Setting can only be modified if power stage is disabled. Modified settings become active the next time the power stage is enabled.	usr_p - -2147483648 -	INT32 R/W per. -	Modbus 1546
<i>MON_swLimP</i>	Positive position limit for software limit switch. If a user-defined value entered is outside of the permissible range, the limit switch limits are automatically set to the maximum user-defined value. Setting can only be modified if power stage is disabled. Modified settings become active the next time the power stage is enabled.	usr_p - 2147483647 -	INT32 R/W per. -	Modbus 1544
<i>MON_tq_win</i>	Torque window, permissible deviation. The torque window can only be activated in operating mode Profile Torque. In increments of 0.1 %. Modified settings become active immediately.	% 0.0 3.0 3000.0	UINT16 R/W per. -	Modbus 1626
<i>MON_tq_winTime</i>	Torque window, time. Value 0: Torque window monitoring deactivated Changing the value causes a restart of torque monitoring. Torque window is only used in operating mode Profile Torque. Modified settings become active immediately.	ms 0 0 16383	UINT16 R/W per. -	Modbus 1628
<i>MON_v_DiffWin</i>	Monitoring of velocity deviation. The system monitors whether the drive is within the defined deviation during the period set with MON_ChkTime. The status can be output via a parameterizable output. Modified settings become active immediately.	usr_v 1 10 2147483647	UINT32 R/W per. -	Modbus 1588
<i>MON_v_Threshold</i>	Monitoring of velocity threshold. The system monitors whether the drive is below the defined value during the period set with MON_ChkTime. The status can be output via a parameterizable output. Modified settings become active immediately.	usr_v 1 10 2147483647	UINT32 R/W per. -	Modbus 1590
<i>MON_v_win</i>	Velocity window, permissible deviation. Modified settings become active immediately.	usr_v 1 10 2147483647	UINT32 R/W per. -	Modbus 1576

Parameter name HMI menu HMI name	Description	Unit Minimum value Factory setting Maximum value	Data type R/W Persistent Expert	Parameter address via fieldbus
<i>MON_v_winTime</i>	Velocity window, time. Value 0: Velocity window monitoring deactivated Changing the value causes a restart of velocity monitoring. Modified settings become active immediately.	ms 0 0 16383	UINT16 R/W per. -	Modbus 1578
<i>MON_v_zeroclamp</i>	Velocity limit for Zero Clamp. A Zero Clamp operation is only possible if the reference velocity is below the Zero Clamp velocity limit. Modified settings become active immediately.	usr_v 0 10 2147483647	UINT32 R/W per. -	Modbus 1616
<i>MON_VelDiff</i>	Maximum load-dependent velocity deviation. Value 0: Monitoring deactivated. Value >0: Maximum value Modified settings become active immediately. Available with firmware version \geq V01.26.	usr_v 0 0 2147483647	UINT32 R/W per. -	Modbus 1686
<i>MON_VelDiff_Time</i>	Time window for maximum load-dependent velocity deviation. Value 0: Monitoring deactivated. Value >0: Time window for maximum value Modified settings become active immediately. Available with firmware version \geq V01.26.	ms 0 10 -	UINT16 R/W per. -	Modbus 1688
<i>MON_VelDiffOpSt578</i>	Maximum load-dependent velocity deviation for operating states 5, 7 and 8. Maximum load-dependent velocity deviation for operating states 5 Switch On, 7 Quick Stop Active and 8 Fault Reaction Active. Value 0: Monitoring deactivated. Value >0: Maximum value. Monitoring is active if parameter <i>LIM_QStopReact</i> is set to "Deceleration Ramp (Fault)" or to "Deceleration ramp (Quick Stop)". Setting can only be modified if power stage is disabled. Modified settings become active the next time the power stage is enabled. Available with firmware version \geq V01.32.	usr_v 0 0 2147483647	UINT32 R/W per. -	Modbus 1680
<i>MT_dismax</i>	Maximum permissible distance. If the reference value is active and the maximum permissible distance is exceeded, an error of error class 1 is detected. The value 0 switches off monitoring. The parameter <i>MT_dismax_usr</i> allows you to enter the value in user-defined units. In increments of 0.1 revolution. Modified settings become active the next time the motor moves.	revolution 0.0 1.0 999.9	UINT16 R/W - -	Modbus 11782

Parameter name HMI menu HMI name	Description	Unit Minimum value Factory setting Maximum value	Data type R/W Persistent Expert	Parameter address via fieldbus
<i>MT_dismax_usr</i>	<p>Maximum permissible distance.</p> <p>If the reference value is active and the maximum permissible distance is exceeded, an error of error class 1 is detected.</p> <p>The value 0 switches off monitoring.</p> <p>The minimum value, the factory setting and the maximum value depend on the scaling factor.</p> <p>Modified settings become active the next time the motor moves.</p> <p>Available with firmware version \geqV01.05.</p>	usr_p 0 16384 2147483647	INT32 R/W - -	Modbus 11796
<i>OFS_Ramp</i>	<p>Acceleration and deceleration for offset movement.</p> <p>Setting can only be modified if power stage is disabled.</p> <p>Modified settings become active the next time the power stage is enabled.</p>	usr_a 1 600 2147483647	UINT32 R/W per. -	Modbus 9996
<i>OFSp_RelPos1</i>	<p>Relative offset position 1 for offset movement.</p> <p>Modified settings become active immediately.</p>	Inc -2147483648 0 2147483647	INT32 R/W per. -	Modbus 10000
<i>OFSp_RelPos2</i>	<p>Relative offset position 2 for offset movement.</p> <p>Modified settings become active immediately.</p>	Inc -2147483648 0 2147483647	INT32 R/W per. -	Modbus 10004
<i>OFSv_target</i>	<p>Target velocity for offset movement.</p> <p>The maximum value is 5000 if the user-defined scaling factor of the velocity scaling is 1.</p> <p>This applies to the user-defined scaling factors. Example: If the user-defined scaling factor of the velocity scaling is 2 (ScaleVELnum = 2, ScaleVELdenom = 1), the maximum value is 2500.</p> <p>Modified settings become active immediately.</p>	usr_v 1 60 2147483647	UINT32 R/W per. -	Modbus 9992
<i>p_PTI_act_set</i>	<p>Position value at PTI interface.</p> <p>Available with firmware version \geqV01.26.</p>	Inc -2147483648 - 2147483647	INT32 R/W - -	Modbus 2130

Parameter name HMI menu HMI name	Description	Unit Minimum value Factory setting Maximum value	Data type R/W Persistent Expert	Parameter address via fieldbus
<i>PAR_CTRLreset</i> <i>CONF → FCS -</i> <i>RES</i>	<p>Reset control loop parameters.</p> <p>0 / No / No: No</p> <p>1 / Yes / YES: Yes</p> <p>Reset of the control loop parameters. The control loop parameters are recalculated on the basis of the motor data of the connected motor.</p> <p>Current and velocity limitations are not reset. Therefore, a user parameter reset is required.</p> <p>The new settings are not saved to the nonvolatile memory.</p> <p>Setting can only be modified if power stage is disabled.</p> <p>Modified settings become active immediately.</p>	- 0 0 1	UINT16 R/W - -	Modbus 1038
<i>PAR_ScalingStart</i>	<p>Recalculation of parameters with user-defined units.</p> <p>The parameters with user-defined units can be recalculated with a changed scaling factor.</p> <p>Value 0: Inactive</p> <p>Value 1: Initialize recalculation</p> <p>Value 2: Start recalculation</p> <p>Setting can only be modified if power stage is disabled.</p> <p>Modified settings become active immediately.</p> <p>Available with firmware version $\geq V01.05$.</p>	- 0 0 2	UINT16 R/W - -	Modbus 1064
<i>PAReepSave</i>	<p>Save parameter values to the nonvolatile memory.</p> <p>Value 1: Save persistent parameters</p> <p>The currently set parameters are saved to the nonvolatile memory.</p> <p>The saving process is complete when the parameter is read and 0 is returned.</p> <p>Modified settings become active immediately.</p>	- - - -	UINT16 R/W - -	Modbus 1026

Parameter name HMI menu HMI name	Description	Unit Minimum value Factory setting Maximum value	Data type R/W Persistent Expert	Parameter address via fieldbus
<i>PARuserReset</i> <i>CONF → FLS -</i> <i>RESU</i>	<p>Reset user parameters.</p> <p>0 / No / No: No</p> <p>65535 / Yes / YES: Yes</p> <p>Bit 0: Reset persistent user parameters and control loop parameters to default values</p> <p>Bits 1 ... 15: Reserved</p> <p>The parameters are reset with the exception of:</p> <ul style="list-style-type: none"> - Communication parameters - Inversion of direction of movement - Type of reference value signal for PTI interface - Operating mode - Settings of encoder simulation - Functions of digital inputs and outputs <p>The new settings are not saved to the EEPROM.</p> <p>Setting can only be modified if power stage is disabled.</p> <p>Modified settings become active the next time the power stage is enabled.</p>	- 0 - 65535	UIN16 R/W - -	Modbus 1040
<i>PP_ModeRangeLim</i>	<p>Absolute movement beyond movement range.</p> <p>0 / NoAbsMoveAllowed: Absolute movement beyond movement range is not possible</p> <p>1 / AbsMoveAllowed: Absolute movement beyond movement range is possible</p> <p>Setting can only be modified if power stage is disabled.</p> <p>Modified settings become active the next time the power stage is enabled.</p> <p>Available with firmware version \geqV01.06.</p>	- 0 0 1	UIN16 R/W per. -	Modbus 8974
<i>PP_OpmChgType</i>	<p>Change to operating mode Profile Position during movements.</p> <p>0 / WithStandStill: Change with standstill</p> <p>1 / OnTheFly: Change without standstill</p> <p>If Modulo is active, a transition to the operating mode Profile Position is performed with the setting WithStandStill, regardless of the setting of this parameter.</p> <p>Setting can only be modified if power stage is disabled.</p> <p>Modified settings become active the next time the power stage is enabled.</p> <p>Available with firmware version \geqV01.06.</p>	- 0 0 1	UIN16 R/W per. -	Modbus 8978

Parameter name HMI menu HMI name	Description	Unit Minimum value Factory setting Maximum value	Data type R/W Persistent Expert	Parameter address via fieldbus
<i>PTI_pulse_filter</i>	<p>Filter time for input signals at the PTI interface.</p> <p>A signal at the PTI interface is only evaluated if it is available for a time that is longer than the set filter time.</p> <p>For example, if an interference pulse is available for a period shorter than the set filter time, the interference pulse is not evaluated.</p> <p>The interval between 2 signals must also be greater than the set filter time.</p> <p>Available with hardware version \geqRS03.</p> <p>In increments of 0.01 μs.</p> <p>Setting can only be modified if power stage is disabled.</p> <p>Modified settings become active the next time the power stage is enabled.</p>	<p>μs</p> <p>0.00</p> <p>0.25</p> <p>13.00</p>	<p>UINT16</p> <p>R/W</p> <p>per.</p> <p>expert</p>	Modbus 1374
<i>PTI_signal_type</i> CONF → 1 - 0 - 1 0 P 1	<p>Type of reference value signal for PTI interface.</p> <p>0 / A/B Signals / RB: Signals ENC_A and ENC_B (quadruple evaluation)</p> <p>1 / P/D Signals / Pd: Signals PULSE and DIR</p> <p>2 / CW/CCW Signals / CW/CCW: Signals clockwise and counterclockwise</p> <p>Setting can only be modified if power stage is disabled.</p> <p>Modified settings become active the next time the product is powered on.</p>	<p>-</p> <p>0</p> <p>0</p> <p>2</p>	<p>UINT16</p> <p>R/W</p> <p>per.</p> <p>-</p>	Modbus 1284
<i>PTO_mode</i>	<p>Type of usage of PTO interface.</p> <p>0 / Off: PTO interface disabled</p> <p>1 / Esim pAct Enc 1: Encoder simulation based on actual position of encoder 1</p> <p>2 / Esim pRef: Encoder simulation based on reference position (_p_ref)</p> <p>3 / PTI Signal: Directly the signal from PTI interface</p> <p>5 / Esim iqRef: Encoder simulation based on reference current</p> <p>Setting can only be modified if power stage is disabled.</p> <p>Modified settings become active the next time the power stage is enabled.</p>	<p>-</p> <p>0</p> <p>1</p> <p>5</p>	<p>UINT16</p> <p>R/W</p> <p>per.</p> <p>-</p>	Modbus 1342
<i>RAMP_tq_enable</i>	<p>Activation of the motion profile for torque.</p> <p>0 / Profile Off: Profile off</p> <p>1 / Profile On: Profile on</p> <p>In the operating mode Profile Torque, the motion profile for torque can be activated or deactivated.</p> <p>In the other operating modes, the motion profile for torque is inactive.</p> <p>Setting can only be modified if power stage is disabled.</p> <p>Modified settings become active immediately.</p>	<p>-</p> <p>0</p> <p>0</p> <p>1</p>	<p>UINT16</p> <p>R/W</p> <p>per.</p> <p>-</p>	Modbus 1624

Parameter name HMI menu HMI name	Description	Unit Minimum value Factory setting Maximum value	Data type R/W Persistent Expert	Parameter address via fieldbus
<i>RAMP_tq_slope</i>	Slope setting of the motion profile for torque. 100.00 % of the torque setting correspond to the continuous stall torque <i>_M_M_0</i> . Example: A ramp setting of 10000.00 %/s results in a torque change of 100.0% of <i>_M_M_0</i> in 0.01s. In increments of 0.1 %/s. Modified settings become active immediately.	%/s 0.1 10000.0 3000000.0	UINT32 R/W per. -	Modbus 1620
<i>RAMP_v_acc</i>	Acceleration of the motion profile for velocity. Writing the value 0 has no effect on the parameter. Modified settings become active the next time the motor moves.	usr_a 1 600 2147483647	UINT32 R/W per. -	Modbus 1556
<i>RAMP_v_dec</i>	Deceleration of the motion profile for velocity. The minimum value depends on the operating mode: Operating modes with minimum value 1: Electronic Gear (velocity synchronization) Profile Velocity Operating modes with minimum value 120: Jog Writing the value 0 has no effect on the parameter. Modified settings become active the next time the motor moves.	usr_a 1 600 2147483647	UINT32 R/W per. -	Modbus 1558
<i>RAMP_v_enable</i>	Activation of the motion profile for velocity. 0 / Profile Off: Profile off 1 / Profile On: Profile on Setting can only be modified if power stage is disabled. Modified settings become active immediately.	- 0 0 1	UINT16 R/W per. -	Modbus 1622
<i>RAMP_v_jerk</i> <i>CONF → drv -</i> <i>JER</i>	Jerk limitation of the motion profile for velocity. 0 / Off / OFF: Off 1 / 1 / 1: 1 ms 2 / 2 / 2: 2 ms 4 / 4 / 4: 4 ms 8 / 8 / 8: 8 ms 16 / 16 / 16: 16 ms 32 / 32 / 32: 32 ms 64 / 64 / 64: 64 ms 128 / 128 / 128: 128 ms Adjustments can only be made if the operating mode is inactive (x_end=1). Modified settings become active the next time the motor moves.	ms 0 0 128	UINT16 R/W per. -	Modbus 1562

Parameter name HMI menu HMI name	Description	Unit Minimum value Factory setting Maximum value	Data type R/W Persistent Expert	Parameter address via fieldbus
<i>RAMP_v_max</i> <i>C o n F → R C G -</i> <i>n r P P</i>	<p>Maximum velocity of the motion profile for velocity.</p> <p>If a greater reference velocity is set in one of these operating modes, it is automatically limited to RAMP_v_max.</p> <p>This way, commissioning at limited velocity is easier to perform.</p> <p>Setting can only be modified if power stage is disabled.</p> <p>Modified settings become active the next time the motor moves.</p>	usr_v 1 13200 2147483647	UINT32 R/W per. -	Modbus 1554
<i>RAMPaccdec</i>	<p>Acceleration and deceleration for the Drive Profile Lexium.</p> <p>High word: Acceleration Low word: Deceleration</p> <p>The values are internally multiplied by 10 (example: 1 = 10 RPM/s).</p> <p>Write access changes the values of RAMP_v_acc and RAMP_v_dec. The limit values are verified on the basis of the values indicated for these parameters.</p> <p>If the value cannot be represented as a 16 bit value, the value is set to 65535 (maximum UINT16 value).</p> <p>Modified settings become active the next time the motor moves.</p>	- - - -	UINT32 R/W - -	Modbus 1540
<i>RAMPquickstop</i>	<p>Deceleration ramp for Quick Stop.</p> <p>Deceleration ramp for a software stop or an error with error class 1 or 2.</p> <p>Modified settings become active the next time the motor moves.</p>	usr_a 1 6000 2147483647	UINT32 R/W per. -	Modbus 1572
<i>RESext_P</i> <i>C o n F → R C G -</i> <i>P o b r</i>	<p>Nominal power of external braking resistor.</p> <p>The maximum value depends on the power stage.</p> <p>Setting can only be modified if power stage is disabled.</p> <p>Modified settings become active the next time the power stage is enabled.</p>	W 1 10 -	UINT16 R/W per. -	Modbus 1316
<i>RESext_R</i> <i>C o n F → R C G -</i> <i>r b r</i>	<p>Resistance value of external braking resistor.</p> <p>The minimum value depends on the power stage.</p> <p>In increments of 0.01 Ω.</p> <p>Setting can only be modified if power stage is disabled.</p> <p>Modified settings become active the next time the power stage is enabled.</p>	Ω - 100.00 327.67	UINT16 R/W per. -	Modbus 1318
<i>RESext_ton</i> <i>C o n F → R C G -</i> <i>t b r</i>	<p>Maximum permissible switch-on time of external braking resistor.</p> <p>Setting can only be modified if power stage is disabled.</p> <p>Modified settings become active the next time the power stage is enabled.</p>	ms 1 1 30000	UINT16 R/W per. -	Modbus 1314

Parameter name HMI menu HMI name	Description	Unit Minimum value Factory setting Maximum value	Data type R/W Persistent Expert	Parameter address via fieldbus
<i>RESint_ext</i> <i>CONF → RCG -</i> <i>Esbr</i>	Selection of type of braking resistor. 0 / Internal Braking Resistor / I n E : Internal braking resistor 1 / External Braking Resistor / E h E : External braking resistor 2 / Reserved / r S V d : Reserved Setting can only be modified if power stage is disabled. Modified settings become active the next time the power stage is enabled.	- 0 0 2	UINT16 R/W per. -	Modbus 1298
<i>RMAC_Edge</i>	Edge of capture signal for relative movement after capture. 0 / Falling edge : Falling edge 1 / Rising edge : Rising edge Available with firmware version \geq V01.10.	- 0 0 1	UINT16 R/W per. -	Modbus 8992
<i>RMAC_Position</i>	Target position of relative movement after capture. Minimum/maximum values depend on: - Scaling factor Modified settings become active the next time the motor moves. Available with firmware version \geq V01.10.	usr_p - 0 -	INT32 R/W per. -	Modbus 8986
<i>RMAC_Response</i>	Response if target position is overtraveled. 0 / Error Class 1 : Error class 1 1 / No Movement To Target Position : No movement to target position 2 / Movement To Target Position : Movement to target position Modified settings become active immediately. Available with firmware version \geq V01.10.	- 0 0 2	UINT16 R/W per. -	Modbus 8990
<i>RMAC_Velocity</i>	Velocity of relative movement after capture. Value 0: Use actual motor velocity Value >0: Value is the target velocity The adjustable value is internally limited to the setting in RAMP_v_max. Modified settings become active the next time the motor moves. Available with firmware version \geq V01.10.	usr_v 0 0 2147483647	UINT32 R/W per. -	Modbus 8988
<i>ScalePOSdenom</i>	Position scaling: Denominator. Refer to numerator (ScalePOSnum) for a description. A new scaling is activated when the numerator value is supplied. Setting can only be modified if power stage is disabled.	usr_p 1 16384 2147483647	INT32 R/W per. -	Modbus 1550

Parameter name HMI menu HMI name	Description	Unit Minimum value Factory setting Maximum value	Data type R/W Persistent Expert	Parameter address via fieldbus
<i>ScalePOSnum</i>	Position scaling: Numerator. Specification of the scaling factor: Motor revolutions ----- User-defined units [usr_p] A new scaling is activated when the numerator value is supplied. Setting can only be modified if power stage is disabled. Modified settings become active immediately.	revolution 1 1 2147483647	INT32 R/W per. -	Modbus 1552
<i>ScaleRAMPdenom</i>	Ramp scaling: Denominator. See numerator (ScaleRAMPnum) for a description. A new scaling is activated when the numerator value is supplied. Setting can only be modified if power stage is disabled.	usr_a 1 1 2147483647	INT32 R/W per. -	Modbus 1632
<i>ScaleRAMPnum</i>	Ramp scaling: Numerator. Setting can only be modified if power stage is disabled. Modified settings become active immediately.	RPM/s 1 1 2147483647	INT32 R/W per. -	Modbus 1634
<i>ScaleVELdenom</i>	Velocity scaling: Denominator. See numerator (ScaleVELnum) for a description. A new scaling is activated when the numerator value is supplied. Setting can only be modified if power stage is disabled.	usr_v 1 1 2147483647	INT32 R/W per. -	Modbus 1602
<i>ScaleVELnum</i>	Velocity scaling: Numerator. Specification of the scaling factor: Speed of rotation of motor [RPM] ----- User-defined units [usr_v] A new scaling is activated when the numerator value is supplied. Setting can only be modified if power stage is disabled. Modified settings become active immediately.	RPM 1 1 2147483647	INT32 R/W per. -	Modbus 1604

Parameter name HMI menu HMI name	Description	Unit Minimum value Factory setting Maximum value	Data type R/W Persistent Expert	Parameter address via fieldbus
<i>ShiftEncWorkRang</i>	<p>Shifting of the encoder working range.</p> <p>0 / Off: Shifting off</p> <p>1 / On: Shifting on</p> <p>After activating the shifting function, the position range of a multiturn encoder is shifted by one half of the range.</p> <p>Example for the position range of a multiturn encoder with 4096 revolutions:</p> <p>Value 0: Position values are between 0 ... 4096 revolutions.</p> <p>Value 1: Position values are between -2048 ... 2048 revolutions.</p> <p>Modified settings become active the next time the product is powered on.</p>	- 0 0 1	UINT16 R/W per. -	Modbus 1346
<i>SimAbsolutePos</i> <i>C o n F → R C G -</i> <i>9 A b S</i>	<p>Simulation of absolute position at power cycling.</p> <p>0 / Simulation Off / o F F: Do not use the last mechanical position after power cycling</p> <p>1 / Simulation On / o n: Use last mechanical position after power cycling</p> <p>This parameter specifies the way position values are handled over a power cycle and allows for the simulation of an absolute position encoder using singleturn encoders.</p> <p>If this function is activated, the drive saves the pertinent position data prior to a power removal so that the drive can restore the mechanical position the next time it is powered on.</p> <p>In the case of singleturn encoders, the position can be restored if the motor shaft has not been moved by more than 0.25 revolutions while the drive was powered off.</p> <p>In the case of multiturn encoders, the permissible shaft movement while the drive is off can be much greater, depending on the type of multiturn encoder.</p> <p>For this function to work, the drive may only be powered off while the motor is at a standstill and the motor shaft must not be moved outside of the permissible range (for example, use a holding brake).</p> <p>Modified settings become active immediately.</p> <p>Available with firmware version ≥V01.03.</p>	- 0 0 1	UINT16 R/W per. -	Modbus 1350
<i>UsrAppDataMem1</i>	<p>User-specific data 1.</p> <p>This parameter can be used to store user-specific data.</p> <p>Modified settings become active immediately.</p> <p>Available with firmware version ≥V01.20.</p>	- - - -	UINT32 R/W per. -	Modbus 390
<i>UsrAppDataMem2</i>	<p>User-specific data 2.</p> <p>This parameter can be used to store user-specific data.</p> <p>Modified settings become active immediately.</p> <p>Available with firmware version ≥V01.20.</p>	- - 0 -	UINT32 R/W per. -	Modbus 392

Accessories and Spare Parts

Commissioning Tools

Description	Reference
PC connection kit, serial connection between drive and PC, USB-A to RJ45	TCSMCNAM3M002P
Multi-Loader, device for copying the parameter settings to a PC or to another drive	VW3A8121
Modbus cable, 1 m (3.28 ft), 2 x RJ45	VW3A8306R10
External graphic display terminal	VW3A1101

Memory Cards

Description	Reference
Memory card for copying parameter settings	VW3M8705
25 memory cards for copying parameter settings	VW3M8704

Adapter Cable for Encoder Signals LXM05/LXM15 to LXM32

Description	Reference
Encoder adapter cable Molex 12-pin (LXM05) to RJ45 10-pin (LXM32), 1 m (3.28 ft)	VW3M8111R10
Encoder adapter cable D15-SUB (LXM15) to RJ45 10-pin (LXM32), 1 m (3.28 ft)	VW3M8112R10

Cables for PTO and PTI

Description	Reference
Signal cable 2 x RJ45, PTO to PTI, 0.3 m (0.98 ft)	VW3M8502R03
Signal cable 2 x RJ45, PTO to PTI, 1.5 m (4.92 ft)	VW3M8502R15
Signal cable 1 x RJ45, other cable end open, for connecting PTI in the control cabinet, 3 m (9.84 ft)	VW3M8223R30

Motor Cables

Motor cables 1.0 mm²

Description	Reference
Motor cable 3 m (9.84 ft), (4 x 1.0 mm ² + 2 x (2 x 0.75 mm ²)) shielded; motor end 8-pin circular connector Y-TEC, other cable end open	VW3M5100R30
Motor cable 5 m (16.4 ft), (4 x 1.0 mm ² + 2 x (2 x 0.75 mm ²)) shielded; motor end 8-pin circular connector Y-TEC, other cable end open	VW3M5100R50
Motor cable 10 m (32.8 ft), (4 x 1.0 mm ² + 2 x (2 x 0.75 mm ²)) shielded; motor end 8-pin circular connector Y-TEC, other cable end open	VW3M5100R100
Motor cable 15 m (49.2 ft), (4 x 1.0 mm ² + 2 x (2 x 0.75 mm ²)) shielded; motor end 8-pin circular connector Y-TEC, other cable end open	VW3M5100R150

Description	Reference
Motor cable 25 m (82 ft), (4 x 1.0 mm ² + 2 x (2 x 0.75 mm ²)) shielded; motor end 8-pin circular connector Y-TEC, other cable end open	VW3M5100R250
Motor cable 100 m (328 ft), (4 x 1.0 mm ² + 2 x (2 x 0.75 mm ²)) shielded; both cable ends open	VW3M5300R1000

Motor cables 1.5 mm²

Description	Reference
Motor cable 1.5 m (4.92 ft), (4 x 1.5 mm ² + (2 x 1 mm ²)) shielded; motor end 8-pin circular connector M23, other cable end open	VW3M5101R15
Motor cable 3 m (9.84 ft), (4 x 1.5 mm ² + (2 x 1 mm ²)) shielded; motor end 8-pin circular connector M23, other cable end open	VW3M5101R30
Motor cable 5 m (16.4 ft), (4 x 1.5 mm ² + (2 x 1 mm ²)) shielded; motor end 8-pin circular connector M23, other cable end open	VW3M5101R50
Motor cable 10 m (32.8 ft), (4 x 1.5 mm ² + (2 x 1 mm ²)) shielded; motor end 8-pin circular connector M23, other cable end open	VW3M5101R100
Motor cable 15 m (49.2 ft), (4 x 1.5 mm ² + (2 x 1 mm ²)) shielded; motor end 8-pin circular connector M23, other cable end open	VW3M5101R150
Motor cable 20 m (65.6 ft), (4 x 1.5 mm ² + (2 x 1 mm ²)) shielded; motor end 8-pin circular connector M23, other cable end open	VW3M5101R200
Motor cable 25 m (82 ft), (4 x 1.5 mm ² + (2 x 1 mm ²)) shielded; motor end 8-pin circular connector M23, other cable end open	VW3M5101R250
Motor cable 50 m (164 ft), (4 x 1.5 mm ² + (2 x 1 mm ²)) shielded; motor end 8-pin circular connector M23, other cable end open	VW3M5101R500
Motor cable 75 m (246 ft), (4 x 1.5 mm ² + (2 x 1 mm ²)) shielded; motor end 8-pin circular connector M23, other cable end open	VW3M5101R750
Motor cable 25 m (82 ft), (4 x 1.5 mm ² + (2 x 1 mm ²)) shielded; both cable ends open	VW3M5301R250
Motor cable 50 m (164 ft), (4 x 1.5 mm ² + (2 x 1 mm ²)) shielded; both cable ends open	VW3M5301R500
Motor cable 100 m (328 ft), (4 x 1.5 mm ² + (2 x 1 mm ²)) shielded; both cable ends open	VW3M5301R1000

Motor cables 2.5 mm²

Description	Reference
Motor cable 3 m (9.84 ft), (4 x 2.5 mm ² + (2 x 1 mm ²)) shielded; motor end 8-pin circular connector M23, other cable end open	VW3M5102R30
Motor cable 5 m (16.4 ft), (4 x 2.5 mm ² + (2 x 1 mm ²)) shielded; motor end 8-pin circular connector M23, other cable end open	VW3M5102R50
Motor cable 10 m (32.8 ft), (4 x 2.5 mm ² + (2 x 1 mm ²)) shielded; motor end 8-pin circular connector M23, other cable end open	VW3M5102R100
Motor cable 15 m (49.2 ft), (4 x 2.5 mm ² + (2 x 1 mm ²)) shielded; motor end 8-pin circular connector M23, other cable end open	VW3M5102R150
Motor cable 20 m (65.6 ft), (4 x 2.5 mm ² + (2 x 1 mm ²)) shielded; motor end 8-pin circular connector M23, other cable end open	VW3M5102R200
Motor cable 25 m (82 ft), (4 x 2.5 mm ² + (2 x 1 mm ²)) shielded; motor end 8-pin circular connector M23, other cable end open	VW3M5102R250
Motor cable 50 m (164 ft), (4 x 2.5 mm ² + (2 x 1 mm ²)) shielded; motor end 8-pin circular connector M23, other cable end open	VW3M5102R500
Motor cable 75 m (246 ft), (4 x 2.5 mm ² + (2 x 1 mm ²)) shielded; motor end 8-pin circular connector M23, other cable end open	VW3M5102R750
Motor cable 25 m (82 ft), (4 x 2.5 mm ² + (2 x 1 mm ²)) shielded; both cable ends open	VW3M5302R250
Motor cable 50 m (164 ft), (4 x 2.5 mm ² + (2 x 1 mm ²)) shielded; both cable ends open	VW3M5302R500
Motor cable 100 m (328 ft), (4 x 2.5 mm ² + (2 x 1 mm ²)) shielded; both cable ends open	VW3M5302R1000

Motor cables 4 mm²

Description	Reference
Motor cable 3 m (9.84 ft), (4 x 4 mm ² + (2 x 1 mm ²)) shielded; motor end 8-pin circular connector M40, other cable end open	VW3M5103R30
Motor cable 5 m (16.4 ft), (4 x 4 mm ² + (2 x 1 mm ²)) shielded; motor end 8-pin circular connector M40, other cable end open	VW3M5103R50
Motor cable 10 m (32.8 ft), (4 x 4 mm ² + (2 x 1 mm ²)) shielded; motor end 8-pin circular connector M40, other cable end open	VW3M5103R100
Motor cable 15 m (49.2 ft), (4 x 4 mm ² + (2 x 1 mm ²)) shielded; motor end 8-pin circular connector M40, other cable end open	VW3M5103R150
Motor cable 20 m (65.6 ft), (4 x 4 mm ² + (2 x 1 mm ²)) shielded; motor end 8-pin circular connector M40, other cable end open	VW3M5103R200
Motor cable 25 m (82 ft), (4 x 4 mm ² + (2 x 1 mm ²)) shielded; motor end 8-pin circular connector M40, other cable end open	VW3M5103R250
Motor cable 50 m (164 ft), (4 x 4 mm ² + (2 x 1 mm ²)) shielded; motor end 8-pin circular connector M40, other cable end open	VW3M5103R500
Motor cable 75 m (246 ft), (4 x 4 mm ² + (2 x 1 mm ²)) shielded; motor end 8-pin circular connector M40, other cable end open	VW3M5103R750
Motor cable 25 m (82 ft), (4 x 4 mm ² + (2 x 1 mm ²)) shielded; both cable ends open	VW3M5303R250
Motor cable 50 m (164 ft), (4 x 4 mm ² + (2 x 1 mm ²)) shielded; both cable ends open	VW3M5303R500
Motor cable 100 m (328 ft), (4 x 4 mm ² + (2 x 1 mm ²)) shielded; both cable ends open	VW3M5303R1000

Motor cables 6 mm²

Description	Reference
Motor cable 3 m (9.84 ft), (4 x 6 mm ² + (2 x 1 mm ²)) shielded; motor end 8-pin circular connector M40, other cable end open	VW3M5105R30
Motor cable 5 m (16.4 ft), (4 x 6 mm ² + (2 x 1 mm ²)) shielded; motor end 8-pin circular connector M40, other cable end open	VW3M5105R50
Motor cable 10 m (32.8 ft), (4 x 6 mm ² + (2 x 1 mm ²)) shielded; motor end 8-pin circular connector M40, other cable end open	VW3M5105R100
Motor cable 15 m (49.2 ft), (4 x 6 mm ² + (2 x 1 mm ²)) shielded; motor end 8-pin circular connector M40, other cable end open	VW3M5105R150
Motor cable 20 m (65.6 ft), (4 x 6 mm ² + (2 x 1 mm ²)) shielded; motor end 8-pin circular connector M40, other cable end open	VW3M5105R200
Motor cable 25 m (82 ft), (4 x 6 mm ² + (2 x 1 mm ²)) shielded; motor end 8-pin circular connector M40, other cable end open	VW3M5105R250
Motor cable 50 m (164 ft), (4 x 6 mm ² + (2 x 1 mm ²)) shielded; motor end 8-pin circular connector M40, other cable end open	VW3M5105R500
Motor cable 75 m (246 ft), (4 x 6 mm ² + (2 x 1 mm ²)) shielded; motor end 8-pin circular connector M40, other cable end open	VW3M5105R750
Motor cable 25 m (82 ft), (4 x 6 mm ² + (2 x 1 mm ²)) shielded; both cable ends open	VW3M5305R250
Motor cable 50 m (164 ft), (4 x 6 mm ² + (2 x 1 mm ²)) shielded; both cable ends open	VW3M5305R500
Motor cable 100 m (328 ft), (4 x 6 mm ² + (2 x 1 mm ²)) shielded; both cable ends open	VW3M5305R1000

Motor cables 10 mm²

Description	Reference
Motor cable 3 m (9.84 ft), (4 x 10 mm ² + (2 x 1 mm ²)) shielded; motor end 8-pin circular connector M40, other cable end open	VW3M5104R30
Motor cable 5 m (16.4 ft), (4 x 10 mm ² + (2 x 1 mm ²)) shielded; motor end 8-pin circular connector M40, other cable end open	VW3M5104R50

Description	Reference
Motor cable 10 m (32.8 ft), (4 x 10 mm ² + (2 x 1 mm ²)) shielded; motor end 8-pin circular connector M40, other cable end open	VW3M5104R100
Motor cable 15 m (49.2 ft), (4 x 10 mm ² + (2 x 1 mm ²)) shielded; motor end 8-pin circular connector M40, other cable end open	VW3M5104R150
Motor cable 20 m (65.6 ft), (4 x 10 mm ² + (2 x 1 mm ²)) shielded; motor end 8-pin circular connector M40, other cable end open	VW3M5104R200
Motor cable 25 m (82 ft), (4 x 10 mm ² + (2 x 1 mm ²)) shielded; motor end 8-pin circular connector M40, other cable end open	VW3M5104R250
Motor cable 50 m (164 ft), (4 x 10 mm ² + (2 x 1 mm ²)) shielded; motor end 8-pin circular connector M40, other cable end open	VW3M5104R500
Motor cable 75 m (246 ft), (4 x 10 mm ² + (2 x 1 mm ²)) shielded; motor end 8-pin circular connector M40, other cable end open	VW3M5104R750
Motor cable 25 m (82 ft), (4 x 10 mm ² + (2 x 1 mm ²)) shielded; both cable ends open	VW3M5304R250
Motor cable 50 m (164 ft), (4 x 10 mm ² + (2 x 1 mm ²)) shielded; both cable ends open	VW3M5304R500
Motor cable 100 m (328 ft), (4 x 10 mm ² + (2 x 1 mm ²)) shielded; both cable ends open	VW3M5304R1000

Encoder Cables

Description	Reference
Encoder cable 3 m (9.84 ft), (3 x 2 x 0.14 mm ² + 2 x 0.34 mm ²) shielded; motor end 12-pin circular connector Y-TEC, device end 10-pin connector RJ45	VW3M8100R30
Encoder cable 5 m (16.4 ft), (3 x 2 x 0.14 mm ² + 2 x 0.34 mm ²) shielded; motor end 12-pin circular connector Y-TEC, device end 10-pin connector RJ45	VW3M8100R50
Encoder cable 10 m (32.8 ft), (3 x 2 x 0.14 mm ² + 2 x 0.34 mm ²) shielded; motor end 12-pin circular connector Y-TEC, device end 10-pin connector RJ45	VW3M8100R100
Encoder cable 15 m (49.2 ft), (3 x 2 x 0.14 mm ² + 2 x 0.34 mm ²) shielded; motor end 12-pin circular connector Y-TEC, device end 10-pin connector RJ45	VW3M8100R150
Encoder cable 25 m (82 ft), (3 x 2 x 0.14 mm ² + 2 x 0.34 mm ²) shielded; motor end 12-pin circular connector Y-TEC, device end 10-pin connector RJ45	VW3M8100R250
Encoder cable 1.5 m (4.92 ft), (3 x 2 x 0.14 mm ² + 2 x 0.34 mm ²) shielded; motor end 12-pin circular connector M23, device end 10-pin connector RJ45	VW3M8102R15
Encoder cable 3 m (9.84 ft), (3 x 2 x 0.14 mm ² + 2 x 0.34 mm ²) shielded; motor end 12-pin circular connector M23, device end 10-pin connector RJ45	VW3M8102R30
Encoder cable 5 m (16.4 ft), (3 x 2 x 0.14 mm ² + 2 x 0.34 mm ²) shielded; motor end 12-pin circular connector M23, device end 10-pin connector RJ45	VW3M8102R50
Encoder cable 10 m (32.8 ft), (3 x 2 x 0.14 mm ² + 2 x 0.34 mm ²) shielded; motor end 12-pin circular connector M23, device end 10-pin connector RJ45	VW3M8102R100
Encoder cable 15 m (49.2 ft), (3 x 2 x 0.14 mm ² + 2 x 0.34 mm ²) shielded; motor end 12-pin circular connector M23, device end 10-pin connector RJ45	VW3M8102R150
Encoder cable 20 m (65.6 ft), (3 x 2 x 0.14 mm ² + 2 x 0.34 mm ²) shielded; motor end 12-pin circular connector M23, device end 10-pin connector RJ45	VW3M8102R200
Encoder cable 25 m (82 ft), (3 x 2 x 0.14 mm ² + 2 x 0.34 mm ²) shielded; motor end 12-pin circular connector M23, device end 10-pin connector RJ45	VW3M8102R250
Encoder cable 50 m (164 ft), (3 x 2 x 0.14 mm ² + 2 x 0.34 mm ²) shielded; motor end 12-pin circular connector M23, device end 10-pin connector RJ45	VW3M8102R500
Encoder cable 75 m (246 ft), (3 x 2 x 0.14 mm ² + 2 x 0.34 mm ²) shielded; motor end 12-pin circular connector M23, device end 10-pin connector RJ45	VW3M8102R750
Encoder cable 25 m (82 ft), (3 x 2 x 0.14 mm ² + 2 x 0.34 mm ²) shielded; both cable ends open	VW3M8222R250
Encoder cable 50 m (164 ft), (3 x 2 x 0.14 mm ² + 2 x 0.34 mm ²) shielded; both cable ends open	VW3M8222R500
Encoder cable 100 m (328 ft), (3 x 2 x 0.14 mm ² + 2 x 0.34 mm ²) shielded; both cable ends open	VW3M8222R1000
Encoder cable 100 m (328 ft), (5 x 2 x 0.25 mm ² + 2 x 0.5 mm ²) shielded; both cable ends open	VW3M8221R1000
Encoder cable 1 m (3.28 ft), shielded; HD15 D-SUB (male); other cable end open	VW3M4701

Connectors

Description	Reference
Connector for motor cable, motor end Y-TEC, 1 mm ² , 5 pieces	VW3M8219
Connector for motor cable, motor end M23, 1.5 ... 2.5 mm ² , 5 pieces	VW3M8215
Connector for motor cable, motor end M40, 4 mm ² , 5 pieces	VW3M8217
Connector for motor cable, motor end M40, 6...10 mm ² , 5 pieces	VW3M8218
Connector for encoder cable, motor end Y-TEC, 5 pieces	VW3M8220
Connector for encoder cable, motor end M23, 5 pieces	VW3M8214
Connector for encoder cable, drive end RJ45 (10 pins), 5 pieces	VW3M2208

The tools required for cable assembly can be ordered directly from the manufacturer.

- Crimping tool for power connector Y-TEC:
Intercontec C0.201.00 or C0.235.00
www.intercontec.com
- Crimping tool for power connector M23/M40:
Coninvers SF-Z0025, SF-Z0026
www.coninvers.com
- Crimping tool for encoder connector Y-TEC:
Intercontec C0.201.00 or C0.235.00
www.intercontec.com
- Crimping tool for encoder connector M23:
Coninvers RC-Z2514
www.coninvers.com
- Crimping tools for encoder connector RJ45 10 pins:
Yamaichi Y-ConTool-11, Y-ConTool-20, Y-ConTool-30
www.yamaichi.com

External Braking Resistors

Description	Reference
Braking resistor IP65; 10 Ω; maximum continuous power 400 W; 0.75 m (2.46 ft) connection cable, 2.1 mm ² (AWG 14)	VW3A7601R07
Braking resistor IP65; 10 Ω; maximum continuous power 400 W; 2 m (6.56 ft) connection cable, 2.1 mm ² (AWG 14)	VW3A7601R20
Braking resistor IP65; 10 Ω; maximum continuous power 400 W; 3 m (9.84 ft) connection cable, 2.1 mm ² (AWG 14)	VW3A7601R30
Braking resistor IP65; 27 Ω; maximum continuous power 100 W; 0.75 m (2.46 ft) connection cable, 2.1 mm ² (AWG 14), UL	VW3A7602R07
Braking resistor IP65; 27 Ω; maximum continuous power 100 W; 2 m (6.56 ft) connection cable, 2.1 mm ² (AWG 14), UL	VW3A7602R20
Braking resistor IP65; 27 Ω; maximum continuous power 100 W; 3 m (9.84 ft) connection cable, 2.1 mm ² (AWG 14), UL	VW3A7602R30
Braking resistor IP65; 27 Ω; maximum continuous power 200 W; 0.75 m (2.46 ft) connection cable, 2.1 mm ² (AWG 14), UL	VW3A7603R07
Braking resistor IP65; 27 Ω; maximum continuous power 200 W; 2 m (6.56 ft) connection cable, 2.1 mm ² (AWG 14), UL	VW3A7603R20
Braking resistor IP65; 27 Ω; maximum continuous power 200 W; 3 m (9.84 ft) connection cable, 2.1 mm ² (AWG 14), UL	VW3A7603R30

Description	Reference
Braking resistor IP65; 27 Ω; maximum continuous power 400 W; 0.75 m (2.46 ft) connection cable, 2.1 mm ² (AWG 14)	VW3A7604R07
Braking resistor IP65; 27 Ω; maximum continuous power 400 W; 2 m (6.56 ft) connection cable, 2.1 mm ² (AWG 14)	VW3A7604R20
Braking resistor IP65; 27 Ω; maximum continuous power 400 W; 3 m (9.84 ft) connection cable, 2.1 mm ² (AWG 14)	VW3A7604R30
Braking resistor IP65; 72 Ω; maximum continuous power 100 W; 0.75 m (2.46 ft) connection cable, 2.1 mm ² (AWG 14), UL	VW3A7605R07
Braking resistor IP65; 72 Ω; maximum continuous power 100 W; 2 m (6.56 ft) connection cable, 2.1 mm ² (AWG 14), UL	VW3A7605R20
Braking resistor IP65; 72 Ω; maximum continuous power 100 W; 3 m (9.84 ft) connection cable, 2.1 mm ² (AWG 14), UL	VW3A7605R30
Braking resistor IP65; 72 Ω; maximum continuous power 200 W; 0.75 m (2.46 ft) connection cable, 2.1 mm ² (AWG 14), UL	VW3A7606R07
Braking resistor IP65; 72 Ω; maximum continuous power 200 W; 2 m (6.56 ft) connection cable, 2.1 mm ² (AWG 14), UL	VW3A7606R20
Braking resistor IP65; 72 Ω; maximum continuous power 200 W; 3 m (9.84 ft) connection cable, 2.1 mm ² (AWG 14), UL	VW3A7606R30
Braking resistor IP65; 72 Ω; maximum continuous power 400 W; 0.75 m (2.46 ft) connection cable, 2.1 mm ² (AWG 14)	VW3A7607R07
Braking resistor IP65; 72 Ω; maximum continuous power 400 W; 2 m (6.56 ft) connection cable, 2.1 mm ² (AWG 14)	VW3A7607R20
Braking resistor IP65; 72 Ω; maximum continuous power 400 W; 3 m (9.84 ft) connection cable, 2.1 mm ² (AWG 14)	VW3A7607R30
Braking resistor IP65; 100 Ω; maximum continuous power 100 W; 0.75 m (2.46 ft) connection cable, 2.1 mm ² (AWG 14), UL	VW3A7608R07
Braking resistor IP65; 100 Ω; maximum continuous power 100 W; 2 m (6.56 ft) connection cable, 2.1 mm ² (AWG 14), UL	VW3A7608R20
Braking resistor IP65; 100 Ω; maximum continuous power 100 W; 3 m (9.84 ft) connection cable, 2.1 mm ² (AWG 14), UL	VW3A7608R30
Braking resistor IP20; 16 Ω; maximum continuous power 960 W; M6 terminals, UL	VW3A7733
Braking resistor IP20; 10 Ω; maximum continuous power 960 W; M6 terminals, UL	VW3A7734

DC Bus Accessories

Description	Reference
DC bus connection cable, 0.1 m (0.33 ft), 2 * 6 mm ² (2 * AWG 10), pre-assembled, 5 pieces	VW3M7101R01
DC bus connection cable, 15 m (49.2 ft), 2 * 6 mm ² (2 * AWG 10), Twisted Pair, shielded	VW3M7102R150
DC bus connector kit, connector housing and crimp contacts for 3 ... 6 mm ² (AWG 12 ... 10), 10 pieces	VW3M2207

A crimping tool is required for the crimp contacts of the connector kit.
Manufacturer:

Tyco Electronics, Heavy Head Hand Tool, Tool Pt. No 180250

Mains Reactors

Description	Reference
Mains reactor single-phase; 50-60 Hz; 7 A; 5 mH; IP00	VZ1L007UM50
Mains reactor single-phase; 50-60 Hz; 18 A; 2 mH; IP00	VZ1L018UM20

Description	Reference
Mains reactor three-phase; 50-60 Hz; 16 A; 2 mH; IP00	VW3A4553
Mains reactor three-phase; 50-60 Hz; 30 A; 1 mH; IP00	VW3A4554

External Mains Filters

Description	Reference
Mains filter single-phase; 9 A; 115/230 Vac	VW3A4420
Mains filter single-phase; 16 A; 115/230 Vac	VW3A4421
Mains filter three-phase; 15 A; 208/400/480 Vac	VW3A4422
Mains filter three-phase; 25 A; 208/400/480 Vac	VW3A4423

Spare Parts Connectors, Fans, Cover Plates

Description	Reference
Connector kit LXM32C: 3 x AC power stage supply (230/400 Vac), 1 x control supply, 3 x digital inputs/outputs (6-pin), 2 x motor (10 A / 24 A), 1 x holding brake	VW3M2201
Cooling fan kit 40 x 40 mm (1.57 x 1.57 in), plastic housing, with connection cable	VW3M2401
Cooling fan kit 60 x 60 mm (2.36 x 2.36 in), plastic housing, with connection cable	VW3M2402
Cooling fan kit 80 x 80 mm (3.15 x 3.15 in), plastic housing, with connection cable	VW3M2403

Service, Maintenance, and Disposal

Maintenance

Maintenance Plan

Inspect the product for pollution or damage at regular intervals.

Repairs may only be made by the manufacturer.

Prior to any type of work on the drive system, consult the sections on Installation and Commissioning for information on the precautions and processes to be observed.

Include the following points in the maintenance plan of your machine.

Connections and Fastening

- Inspect all connection cables and connectors regularly for damage. Replace damaged cables immediately.
- Verify that all output elements are firmly seated.
- Tighten all mechanical and electrical threaded connections to the specified torque.

Lifetime Safety Function STO

The STO safety function is designed for a lifetime of 20 years. After this period, the data of the safety function are no longer valid. The expiry date is determined by adding 20 years to the DOM shown on the nameplate of the product.

This date must be included in the maintenance plan of the system.

Do not use the safety function after this date.

Example:

The DOM on the nameplate of the product is shown in the format DD.MM.YY, for example 31.12.20. (31 December 2020). This means: Do not use the safety function after December 31, 2040.

Replacing the Product

Description

Unsuitable parameter values or unsuitable data may trigger unintended movements, trigger signals, damage parts and disable monitoring functions. Some parameter values or data do not become active until after a restart.

▲ WARNING

UNINTENDED EQUIPMENT OPERATION

- Only start the system if there are no persons or obstructions in the zone of operation.
- Do not operate the drive system with undetermined parameter values or data.
- Never modify a parameter value unless you fully understand the parameter and all effects of the modification.
- Restart the drive and verify the saved operational data and/or parameter values after modifications.
- Carefully run tests for all operating states and potential error situations when commissioning, upgrading or otherwise modifying the operation of the drive.
- Verify the functions after replacing the product and also after making modifications to the parameter values and/or other operational data.

Failure to follow these instructions can result in death, serious injury, or equipment damage.

Follow the procedure below for replacing devices.

- Save all parameter settings. To do so, use a memory card or save the data to a PC using the commissioning software, see *Parameter Management*, page 157.
- Power off all supply voltages. Verify that no voltages are present (safety instructions), see *Product Related Information*, page 13.
- Label all connections and remove all connection cables (unlock connector locks).
- Uninstall the product.
- Note the identification number and the serial number shown on the product nameplate for later identification.
- Install the new product as per section *Installation*, page 80.
- If the product to be installed has previously been used in a different system or application, you must restore the factory settings before commissioning the product.
- Commission the product as per section *Commissioning*, page 109.

Replacement of the Motor

Description

Drive systems may perform unintended movements if unapproved combinations of drive and motor are used. Though the connectors for motor connection and encoder connection may match mechanically, this does not imply that the motor is approved for use.

⚠ WARNING

UNINTENDED MOVEMENT

Only use approved combinations of drive and motor.

Failure to follow these instructions can result in death, serious injury, or equipment damage.

- Power off all supply voltages. Verify that no voltages are present (safety instructions), see *Product Related Information*, page 13.
- Label all connections and uninstall the product.
- Note the identification number and the serial number shown on the product nameplate for later identification.
- Install the new product as per section *Installation*, page 80.

If the connected motor is replaced by another motor, the motor data set is read again. If the device detects a different motor type, the control loop parameters are recalculated and the HMI displays $\Pi \square E$. See section *Acknowledging a Motor Change*, page 273 for additional information.

If the motor is replaced, the encoder parameters must also be re-adjusted, see *Setting Parameters for Encoder*, page 138.

Changing the Motor Type Temporarily

If you want to operate the new motor type only temporarily via the device, press ESC at the HMI.

The newly calculated control loop parameters are not saved to the nonvolatile memory. This way, you can resume operation with the original motor using the saved control loop parameters.

Changing the Motor Type Permanently

If you want to operate the new motor type permanently via this device, press the navigation button at the HMI.

The newly calculated control loop parameters are saved to the nonvolatile memory.

See also *Acknowledging a Motor Change*, page 273.

Shipping, Storage, Disposal

Shipping

The product must be protected against shocks during transportation. If possible, use the original packaging for shipping.

Storage

The product may only be stored in spaces where the specified permissible ambient conditions are met.

Protect the product from dust and dirt.

Disposal

The product consists of various materials that can be recycled. Dispose of the product in accordance with local regulations.

Visit <https://www.se.com/green-premium> for information and documents on environmental protection as per ISO 14025 such as:

- EoLi (Product End-of-Life Instructions)
- PEP (Product Environmental Profile)

Glossary

A

Actual value:

In control engineering, the actual value is the value of the controlled variable at a given instant (for example, actual velocity, actual torque, actual position, actual current, and so on). An actual value can be a measured value (for example, the actual position can be a value measured by an encoder) or a derived value (for example, the actual torque can be a value derived from the actual current). The actual value is an input value used by the control loops of the drive to reach the reference value. Definition as per IEC 61800-7 series and IEC 60050.

C

CCW:

Counter Clockwise.

CW:

Clockwise.

D

DC bus:

Circuit that supplies the power stage with energy (direct voltage).

Degree of protection:

The degree of protection is a standardized specification for electrical equipment that describes the protection against the ingress of foreign objects and water (for example: IP 20).

Direction of movement :

In the case of a rotary motors, direction of movement is defined in accordance with IEC 61800-7-204: Positive direction is when the motor shaft rotates clockwise as you look at the end of the protruding motor shaft.

DOM:

Date of manufacturing: The nameplate of the product shows the date of manufacture in the format DD.MM.YY or in the format DD.MM.YYYY. For example:

31.12.19 corresponds to December 31, 2019.

31.12.2019 corresponds to December 31, 2019.

Drive system:

System consisting of controller, drive and motor.

E

EMC:

Electromagnetic compatibility

Encoder :

Sensor that converts a measured distance or angle into an electrical signal. This signal is evaluated by the drive to determine the actual position of a shaft (rotor) or a driving unit.

Error class :

Classification of errors into groups. The different error classes allow for specific responses to errors, for example by severity.

Error:

Discrepancy between a detected (computed, measured or signaled) value or condition and the specified or theoretically correct value or condition.

F**Factory settings:**

Settings when the product is shipped.

Fault Reset:

Function used to exit the operating state Fault. Before the function is used, the cause of the detected error must be removed.

Fault:

Fault is an operating state. If the monitoring functions detect an error, a transition to this operating state is triggered, depending on the error class. A "Fault Reset" or a power cycle are required to exit this operating state. Prior to this, the cause of the detected error must be removed. Further information can be found in the pertinent standards such as IEC 61800-7, ODVA Common Industrial Protocol (CIP).

I**I/O:**

Inputs/outputs

I²t monitoring:

Anticipatory temperature monitoring. The expected temperature rise of components is calculated in advance on the basis of the motor current. If a limit value is exceeded, the drive reduces the motor current.

Inc:

Increments

Index pulse:

Signal of an encoder to reference the rotor position in the motor. The encoder returns one index pulse per revolution.

Internal units:

Resolution of the power stage at which the motor can be positioned. Internal units are specified in increments.

L**Limit switch:**

Switches that signal overtravel of the permissible range of travel.

M**Monitoring function:**

Monitoring functions acquire a value continuously or cyclically (for example, by measuring) in order to check whether it is within permissible limits. Monitoring functions are used for error detection. Monitoring functions are not safety functions.

P

Parameter :

Device data and values that can be read and set (to a certain extent) by the user.

PELV:

Protective Extra Low Voltage, low voltage with isolation. For more information: IEC 60364-4-41

Persistent:

Indicates whether the value of the parameter remains in the memory after the device is switched off.

Power stage :

The power stage controls the motor. The power stage generates current for controlling the motor on the basis of the motion signals from the controller.

Pulse/direction signals:

Digital signals with variable pulse frequencies which signal changes in position and direction of movement via separate signal wires.

Q

Quick Stop:

The function can be used for fast deceleration of a movement as a response to a detected error or via a command.

R

RCD:

RCD residual current device.

rms:

"Root Mean Square" value of a voltage (V_{rms}) or a current (A_{rms})

RS485 :

Fieldbus interface as per EIA-485 which enables serial data transmission with multiple devices.

S

Safety-related function:

Safety-related functions are defined in the standard IEC 61800-5-2 (for example, Safe Torque Off (STO), Safe Operating Stop (SOS) or Safe Stop 1 (SS1)).

Scaling factor:

This factor is the ratio between an internal unit and a user-defined unit.

U

User-defined unit:

Unit whose reference to motor movement can be determined by the user via parameters.

Index

24 Vdc control supply	36	parameter <i>_AT_J</i>	146, 300
A		parameter <i>_AT_M_friction</i>	146, 301
access channels	162	parameter <i>_AT_M_load</i>	146, 301
approved motors	28	parameter <i>_AT_progress</i>	145, 301
automatic reading of the motor data record	126	parameter <i>_AT_state</i>	145, 301
		parameter <i>_CommutCntAct</i>	301
B		parameter <i>_Cond_State4</i>	301
Braking resistor:Selection	67	parameter <i>_CTRL_ActParSet</i>	148, 193, 301
		parameter <i>_CTRL_KPid</i>	302
C		parameter <i>_CTRL_KPiq</i>	302
cable specifications	60	parameter <i>_CTRL_TNid</i>	302
capacitor and braking resistor	45	parameter <i>_CTRL_TNiq</i>	302
category 0 stop	74	parameter <i>_DCOMstatus</i>	302
category 1 stop	75	parameter <i>_DEV_T_current</i>	302
components and interfaces	20	parameter <i>_DPL_BitShiftRefA16</i>	303
controller structure	147	parameter <i>_DPL_driveInput</i>	303
		parameter <i>_DPL_driveStat</i>	303
		parameter <i>_DPL_mfStat</i>	303
		parameter <i>_DPL_motionStat</i>	303
		parameter <i>_ENC_AmplMax</i>	303
		parameter <i>_ENC_AmplMean</i>	303
		parameter <i>_ENC_AmplMin</i>	303
		parameter <i>_ENC_AmplVal</i>	303
		parameter <i>_GEAR_p_diff</i>	304
		parameter <i>_hwVersCPU</i>	304
		parameter <i>_hwVersPS</i>	304
		parameter <i>_I_act</i>	304
		parameter <i>_Id_act_rms</i>	304
		parameter <i>_Id_ref_rms</i>	304
		parameter <i>_Imax_act</i>	304
		parameter <i>_Imax_system</i>	305
		parameter <i>_InvalidParam</i>	305
		parameter <i>_IO_act</i>	305
		parameter <i>_IO_DI_act</i>	305
		parameter <i>_IO_DQ_act</i>	305
		parameter <i>_IO_STO_act</i>	306
		parameter <i>_Iq_act_rms</i>	306
		parameter <i>_Iq_ref_rms</i>	306
		parameter <i>_LastError</i>	306
		parameter <i>_LastWarning</i>	306
		parameter <i>_M_BRK_T_apply</i>	306
		parameter <i>_M_BRK_T_release</i>	306
		parameter <i>_M_Enc_Cosine</i>	306
		parameter <i>_M_Enc_Sine</i>	306
		parameter <i>_M_Encoder</i>	307
		parameter <i>_M_HoldingBrake</i>	307
		parameter <i>_M_I_0</i>	307
		parameter <i>_M_I_max</i>	307
		parameter <i>_M_I_nom</i>	307
		parameter <i>_M_I2t</i>	307
		parameter <i>_M_Jrot</i>	307
		parameter <i>_M_kE</i>	308
		parameter <i>_M_L_d</i>	308
		parameter <i>_M_load</i>	264, 308
		parameter <i>_M_L_q</i>	308
		parameter <i>_M_M_0</i>	308
		parameter <i>_M_maxoverload</i>	265, 308
		parameter <i>_M_M_max</i>	308
		parameter <i>_M_M_nom</i>	308
		parameter <i>_M_n_max</i>	308
		parameter <i>_M_n_nom</i>	309
		parameter <i>_M_overload</i>	265, 309
		parameter <i>_M_Polepair</i>	309
		parameter <i>_M_PolePairPitch</i>	309
		parameter <i>_M_R_UV</i>	309
		parameter <i>_M_T_current</i>	263, 309
		parameter <i>_M_T_max</i>	263, 309
		parameter <i>_M_Type</i>	309
		parameter <i>_M_U_max</i>	309
parameter <i>_AccessInfo</i>	163, 300		
parameter <i>_AI1_act</i>	129, 300		
parameter <i>_AI2_act</i>	129, 300		

parameter <i>M_U_nom</i>	309	parameter <i>AbsHomeRequest</i>	317
parameter <i>n_act</i>	310	parameter <i>AccessLock</i>	163, 318
parameter <i>n_act_ENC1</i>	310	parameter <i>AI1_I_max</i>	245, 318
parameter <i>n_ref</i>	310	parameter <i>AI1_mode</i>	227, 232, 241, 244, 318
parameter <i>OpHours</i>	310	parameter <i>AI1_M_scale</i>	228, 318
parameter <i>p_absENC</i>	138, 310	parameter <i>AI1_offset</i>	130, 318
parameter <i>p_absmodulo</i>	310	parameter <i>AI1_Tau</i>	318
parameter <i>p_act</i>	310	parameter <i>AI1_v_max</i>	242, 319
parameter <i>p_act_ENC1</i>	310	parameter <i>AI1_v_scale</i>	233, 319
parameter <i>p_act_ENC1_int</i>	310	parameter <i>AI1_win</i>	130, 319
parameter <i>p_act_int</i>	310	parameter <i>AI2_I_max</i>	245, 319
parameter <i>p_addGEAR</i>	311	parameter <i>AI2_mode</i>	227, 232, 241, 244, 320
parameter <i>PAR_ScalingError</i>	312	parameter <i>AI2_M_scale</i>	228, 319
parameter <i>PAR_ScalingState</i>	312	parameter <i>AI2_offset</i>	130, 320
parameter <i>p_dif</i>	311	parameter <i>AI2_Tau</i>	320
parameter <i>p_dif_load</i>	311	parameter <i>AI2_v_max</i>	242, 320
parameter <i>p_dif_load_peak</i>	311	parameter <i>AI2_v_scale</i>	233, 320
parameter <i>p_dif_load_peak_usr</i>	253, 311	parameter <i>AI2_win</i>	130, 320
parameter <i>p_dif_load_usr</i>	253, 311	parameter <i>AT_dir</i>	144, 321
parameter <i>p_dif_usr</i>	311	parameter <i>AT_dis</i>	321
parameter <i>Power_mean</i>	312	parameter <i>AT_dis_usr</i>	144, 321
parameter <i>p_PTI_act</i>	312	parameter <i>AT_mechanical</i>	145, 321
parameter <i>p_ref</i>	312	parameter <i>AT_n_ref</i>	322
parameter <i>p_ref_int</i>	312	parameter <i>AT_start</i>	145, 322
parameter <i>pref_acc</i>	312	parameter <i>AT_v_ref</i>	322
parameter <i>pref_v</i>	313	parameter <i>AT_wait</i>	146, 322
parameter <i>prgNoDEV</i>	313	parameter <i>BLSH_Mode</i>	251, 322
parameter <i>prgRevDEV</i>	313	parameter <i>BLSH_Position</i>	250, 322
parameter <i>prgVerDEV</i>	313	parameter <i>BLSH_Time</i>	250, 322
parameter <i>PS_I_max</i>	313	parameter <i>BRK_AddT_apply</i>	135, 323
parameter <i>PS_I_nom</i>	313	parameter <i>BRK_AddT_release</i>	134, 323
parameter <i>PS_load</i>	264, 313	parameter <i>CLSET_ParSwiCond</i>	195, 324
parameter <i>PS_maxoverload</i>	265, 313	parameter <i>CLSET_p_DiffWin</i>	323
parameter <i>PS_overload</i>	265, 313	parameter <i>CLSET_p_DiffWin_usr</i>	195, 323
parameter <i>PS_overload_cte</i>	314	parameter <i>CLSET_v_Threshold</i>	196, 324
parameter <i>PS_overload_I2t</i>	314	parameter <i>CLSET_winTime</i>	196, 324
parameter <i>PS_overload_psq</i>	314	parameter <i>CommutCntCred</i>	325
parameter <i>PS_T_current</i>	263, 314	parameter <i>CommutCntMax</i>	325
parameter <i>PS_T_max</i>	263, 314	parameter <i>CTRL_GlobGain</i>	146, 325
parameter <i>PS_T_warn</i>	263, 314	parameter <i>CTRL_I_max</i>	128, 325
parameter <i>PS_U_maxDC</i>	314	parameter <i>CTRL_I_max_fw</i>	326
parameter <i>PS_U_minDC</i>	314	parameter <i>CTRL_KFAcc</i>	326
parameter <i>PS_U_minStopDC</i>	314	parameter <i>CTRL_ParChgTime</i>	148, 196, 326
parameter <i>RAMP_p_act</i>	314	parameter <i>CTRL_ParSetCopy</i>	196, 326
parameter <i>RAMP_p_target</i>	315	parameter <i>CTRL_PwrUpParSet</i>	193, 326
parameter <i>RAMP_v_act</i>	315	parameter <i>CTRL_SelParSet</i>	148, 193, 327
parameter <i>RAMP_v_target</i>	315	parameter <i>CTRL_SmoothCurr</i>	327
parameter <i>RES_load</i>	264, 315	parameter <i>CTRL_SpdFric</i>	327
parameter <i>RES_maxoverload</i>	265, 315	parameter <i>CTRL_TAUnact</i>	327
parameter <i>RES_overload</i>	265, 315	parameter <i>CTRL_VelObsActiv</i>	327
parameter <i>RESint_P</i>	315	parameter <i>CTRL_VelObsDyn</i>	328
parameter <i>RESint_R</i>	315	parameter <i>CTRL_VelObsInert</i>	328
parameter <i>RMAC_DetailStatus</i>	315	parameter <i>CTRL_v_max</i>	129, 327
parameter <i>RMAC_Status</i>	316	parameter <i>CTRL_vPIDDPart</i>	328
parameter <i>ScalePOSmax</i>	316	parameter <i>CTRL_vPIDDTime</i>	328
parameter <i>ScaleRAMPmax</i>	316	parameter <i>CTRL1_KFPp</i>	198, 328
parameter <i>ScaleVELmax</i>	316	parameter <i>CTRL1_Kfric</i>	199, 328
parameter <i>tq_act</i>	316	parameter <i>CTRL1_KPn</i>	150, 197, 329
parameter <i>UDC_act</i>	316	parameter <i>CTRL1_KPp</i>	155, 197, 329
parameter <i>Ud_ref</i>	316	parameter <i>CTRL1_Nf1bandw</i>	198, 329
parameter <i>Udq_ref</i>	316	parameter <i>CTRL1_Nf1damp</i>	198, 329
parameter <i>Uq_ref</i>	316	parameter <i>CTRL1_Nf1freq</i>	198, 329
parameter <i>v_act</i>	317	parameter <i>CTRL1_Nf2bandw</i>	198, 329
parameter <i>v_act_ENC1</i>	317	parameter <i>CTRL1_Nf2damp</i>	198, 329
parameter <i>v_dif_usr</i>	255, 317	parameter <i>CTRL1_Nf2freq</i>	198, 329
parameter <i>Vmax_act</i>	317	parameter <i>CTRL1_Osupdamp</i>	198, 330
parameter <i>VoltUtil</i>	317	parameter <i>CTRL1_Osupdelay</i>	199, 330
parameter <i>v_PTI_act</i>	317	parameter <i>CTRL1_TAUiref</i>	197, 330
parameter <i>v_ref</i>	317	parameter <i>CTRL1_TAUunref</i>	151, 198, 330

parameter CTRL1_TNn	150, 153, 197, 330	parameter IOfunct_DQ1	178, 350
parameter CTRL2_KFPp	200, 330	parameter IOfunct_DQ2	179, 351
parameter CTRL2_Kfric	201, 330	parameter IOfunct_DQ3	180, 352
parameter CTRL2_KPn	150, 199, 331	parameter IOfunct_DQ4	180, 352
parameter CTRL2_KPp	155, 199, 331	parameter IOSigCurrLim	245, 353
parameter CTRL2_Nf1bandw	200, 331	parameter IOSigLIMN	252, 353
parameter CTRL2_Nf1damp	200, 331	parameter IOSigLIMP	252, 353
parameter CTRL2_Nf1freq	200, 331	parameter IOSigREF	354
parameter CTRL2_Nf2bandw	201, 331	parameter IOSigVelLim	243, 354
parameter CTRL2_Nf2damp	200, 331	parameter Iref_PTIFreqMax	229, 354
parameter CTRL2_Nf2freq	200, 331	parameter JOGstep	214, 354
parameter CTRL2_Osupdamp	201, 332	parameter JOGtime	214, 354
parameter CTRL2_Osupdelay	201, 332	parameter JOGv_fast	213, 354
parameter CTRL2_TAUiref	200, 332	parameter JOGv_slow	213, 354
parameter CTRL2_TAUiref	151, 200, 332	parameter LIM_HaltReaction	237, 355
parameter CTRL2_TNn	150, 153, 199, 332	parameter LIM_I_maxHalt	128, 238, 355
parameter DCbus_compat	332	parameter LIM_I_maxQSTP	128, 240, 355
parameter DCOMcontrol	333	parameter LIM_QStopReact	239, 356
parameter DI_0_Debounce	182, 333	parameter Mains_reactor	356
parameter DI_1_Debounce	182, 333	parameter MBaddress	356
parameter DI_2_Debounce	182, 334	parameter MBbaud	356
parameter DI_3_Debounce	183, 334	parameter MON_ChkTime	258–259, 261–262, 356
parameter DI_4_Debounce	183, 334	parameter MON_commutat	266, 357
parameter DI_5_Debounce	183, 335	parameter MON_ConfModification	357
parameter DPL_dmControl	335	parameter MON_DCbusVdcThresh	357
parameter DPL_intLim	335	parameter MON_ENC_Ampl	357
parameter DPL_RefA16	335	parameter MON_GroundFault	268, 358
parameter DPL_RefB32	335	parameter MON_I_Threshold	262, 358
parameter DS402intLim	336	parameter MON_IO_SelErr1	276, 358
parameter DSM_ShutDownOption	204, 336	parameter MON_IO_SelErr2	276, 358
parameter ENC1_adjustment	139, 337	parameter MON_IO_SelWar1	276, 358
parameter ErrorResp_Flt_AC	266, 337	parameter MON_IO_SelWar2	276, 358
parameter ErrorResp_I2tRES	337	parameter MON_MainsVolt	267, 359
parameter ErrorResp_p_dif	254, 338	parameter MON_MotOvLoadOvTemp	359
parameter ErrorResp_QuasiAbs	338	parameter MON_p_dif_load	359
parameter ErrorResp_v_dif	256, 338	parameter MON_p_dif_load_usr	254, 360
parameter ESIM_HighResolution	186, 338	parameter MON_p_dif_warn	254, 360
parameter ESIM_PhaseShift	187, 339	parameter MON_p_DiffWin	360
parameter ESIM_scale	186, 339	parameter MON_p_DiffWin_usr	258, 360
parameter GEARdenom	219, 339	parameter MON_p_win	360
parameter GEARdenom2	220, 339	parameter MON_p_win_usr	361
parameter GEARdir_enabl	223, 339	parameter MON_p_winTime	361
parameter GEARjerklim	237, 339	parameter MON_p_winTout	361
parameter GEARnum	219, 340	parameter MON_SW_Limits	361
parameter GEARnum2	220, 340	parameter MON_SWLimMode	361
parameter GEARpos_v_max	222, 340	parameter MON_swLimN	362
parameter GEARposChgMode	221, 340	parameter MON_swLimP	362
parameter GEARratio	219, 341	parameter MON_tq_win	362
parameter HMIDispPara	341	parameter MON_tq_winTime	362
parameter HMIlocked	163, 341	parameter MON_v_DiffWin	259, 362
parameter InvertDirOfCount	184, 341	parameter MON_VelDiff	255, 363
parameter InvertDirOfMove	138, 342	parameter MON_VelDiff_Time	255, 363
parameter IO_AutoEnable	342	parameter MON_VelDiffOpSt578	363
parameter IO_AutoEnaConfig	342	parameter MON_v_Threshold	261, 362
parameter IO_FaultResOnEnalnp	206, 342	parameter MON_v_win	362
parameter IO_GEARmethod	220, 342	parameter MON_v_winTime	363
parameter IO_I_limit	245, 343	parameter MON_v_zeroclamp	246, 363
parameter IO_JOGmethod	214, 343	parameter MT_dismax	363
parameter IO_ModeSwitch	209, 343	parameter MT_dismax_usr	364
parameter IO_PTtq_reference	226, 343	parameter OFS_Ramp	222, 364
parameter IO_v_limit	242, 343	parameter OFSp_RelPos1	221, 364
parameter IOdefaultMode	208, 343	parameter OFSp_RelPos2	221, 364
parameter IOfunct_DI0	171, 344	parameter OFSv_target	222, 364
parameter IOfunct_DI1	171, 344	parameter PAR_CTRLreset	365
parameter IOfunct_DI2	172, 345	parameter PAR_ScalingStart	365
parameter IOfunct_DI3	173, 346	parameter PAReeprSave	365
parameter IOfunct_DI4	174, 347	parameter PARuserReset	160, 366
parameter IOfunct_DI5	175, 348	parameter PP_ModeRangeLim	366
parameter IOfunct_DQ0	178, 349	parameter PP_OpmChgType	366

parameter <i>p_PTI_act_set</i>	185, 364
parameter <i>PTI_pulse_filter</i>	367
parameter <i>PTI_signal_type</i>	184, 367
parameter <i>PTO_mode</i>	185, 367
parameter <i>RAMP_tq_enable</i>	228, 367
parameter <i>RAMP_tq_slope</i>	228, 368
parameter <i>RAMP_v_acc</i>	235, 368
parameter <i>RAMP_v_dec</i>	235, 368
parameter <i>RAMP_v_enable</i>	235, 368
parameter <i>RAMP_v_jerk</i>	236, 368
parameter <i>RAMP_v_max</i>	235, 369
parameter <i>RAMPaccdec</i>	369
parameter <i>RAMPquickstop</i>	239, 369
parameter <i>RESext_P</i>	142, 369
parameter <i>RESext_R</i>	142, 369
parameter <i>RESext_ton</i>	142, 369
parameter <i>RESint_ext</i>	142, 370
parameter <i>RMAC_Edge</i>	248, 370
parameter <i>RMAC_Position</i>	248, 370
parameter <i>RMAC_Response</i>	249, 370
parameter <i>RMAC_Velocity</i>	248, 370
parameter <i>ScalePOSdenom</i>	166, 370
parameter <i>ScalePOSnum</i>	166, 371
parameter <i>ScaleRAMPdenom</i>	168, 371
parameter <i>ScaleRAMPnum</i>	168, 371
parameter <i>ScaleVELdenom</i>	167, 371
parameter <i>ScaleVELnum</i>	167, 371
parameter <i>ShiftEncWorkRang</i>	140, 372
parameter <i>SimAbsolutePos</i>	372
parameter <i>UsrAppDataMem1</i>	372
parameter <i>UsrAppDataMem2</i>	372
pollution degree and degree of protection.....	24
powering on the drive.....	126
PWM frequency power stage.....	28

Q

qualification of personnel.....	9
---------------------------------	---

R

replacing the product.....	381
representation of the parameters.....	298
restoring factory settings.....	161

S

sampling period.....	189–191
scaling factor.....	165
setting limit values.....	126
shipping.....	382
state transitions.....	203
storage.....	383

T

type code.....	22
----------------	----

U

user-defined units.....	165
usr_a.....	165
usr_p.....	165
usr_v.....	165

Schneider Electric
35 rue Joseph Monier
92500 Rueil Malmaison
France

+ 33 (0) 1 41 29 70 00

www.se.com

As standards, specifications, and design change from time to time,
please ask for confirmation of the information given in this publication.

© 2021 – Schneider Electric. All rights reserved.

0198441113761.12