

# Esmi Impresia Heat Detector

Instruction Sheet  
R10215GB0



## **Schneider Electric Fire & Security Oy**

Sokerilinnantie 11 C  
FI-02600 Espoo, Finland  
Tel: +358 10 446 511  
Website: [www.se.com](http://www.se.com)  
Document number: R10215GB0  
Published: 18.12.2020

© 2020 – Schneider Electric. All Rights Reserved. This information is only to be used as guidance. Subject to changes and errors.

# 1 Esmi Impresia Heat Detector

Esmi Impresia Heat Detector (FFS06741002) is an addressable heat detector with built-in isolator module, designed for installing in addressable fire alarm systems with Esmi ELC loop controller supporting Schneider Electric communication protocol. The detector is compatible with Esmi Impresia Standard Base (FFS06741018).

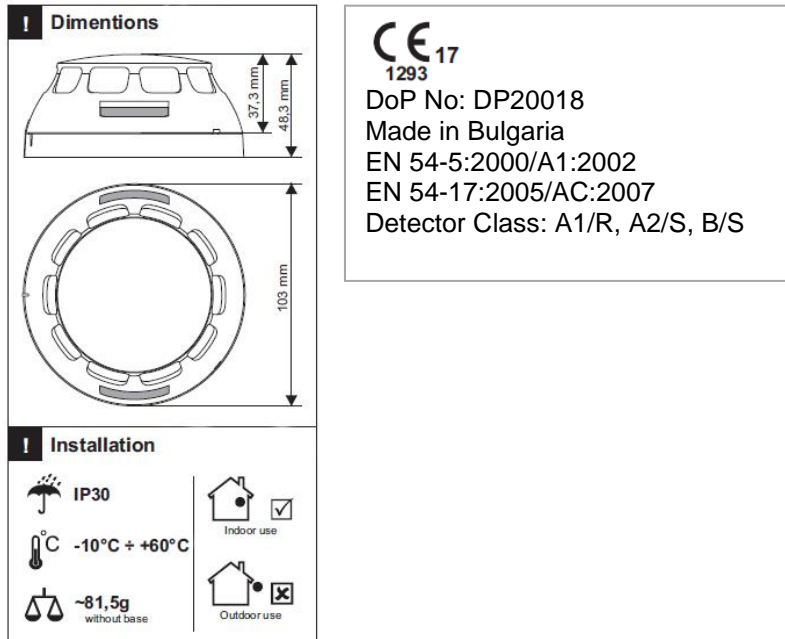

## 1.1 Testing

Before testing make sure all persons on the building are aware of the test. If needed disconnect fire alarm devices, alarm transmitters and other fire outputs before the test. Use Solo "No Climb" tester to test the detector after installation. Follow the testers manufacturer instruction how to run smoke and heat test.

## 1.2 Installation Instructions

1. Follow the local installation instructions.  
Do not install the detector near sources of steam, smoke, condensation or heat.
2. If needed, lock the detector to the base by removing a small tab on the detector as shown on the picture 1.
3. Install the detector base into a flat surface by using appropriate screws.
4. Connect the loop wiring as shown on picture 3. NOTE! The loop power must be disconnected during installation.

5. Insert the detector to the base by turning it clockwise on the base until it drops into place.  
A stripe on the detector side match to the short stipe of the base. Continue to turn the detector until the stripe on the detector meet the longer stipe on the base - a click is heard. See picture 4.
6. Test the detector functionality with Solo no climb tester.
7. If the detector is locked into the base it can be removed by pressing the lid with a small flat head screwdriver and gently turning the detector counter clockwise at the same time. (Picture 6)

