

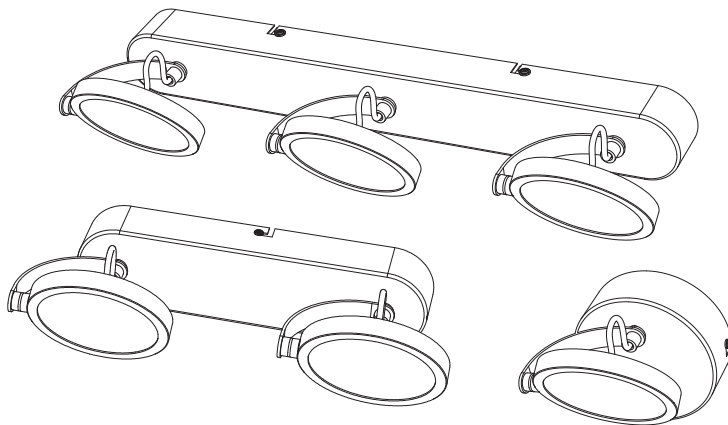



SUN@HOME BATHROOM ROUND



	EAN	This product contains a light source of energy efficiency class	Contained Light Source
SUN@HOME BATHROOM ROUND 110 IP44	4058075750616	G	Contains 1 light source 
SUN@HOME BATHROOM ROUND 300 IP44	4058075750630	G	Contains 2 light sources 
SUN@HOME BATHROOM ROUND 450 IP44	4058075750654	G	Contains 3 light sources 

	EAN	W	Lumen module lm	Lumen output lm	K	⊘ (°C)	V~	mA	Hz	DF	▽°	👉
SUN@HOME BATHROOM ROUND 110 IP44	4058075750616	7.5	520	200	2200-5000	-20...+40	220-240	55	50/60	≥0.5	110	15000
SUN@HOME BATHROOM ROUND 300 IP44	4058075750630	14	1040	460	2200-5000	-20...+40	220-240	60	50/60	≥0.7	110	15000
SUN@HOME BATHROOM ROUND 450 IP44	4058075750654	20	1560	700	2200-5000	-20...+40	220-240	80	50/60	≥0.7	110	15000

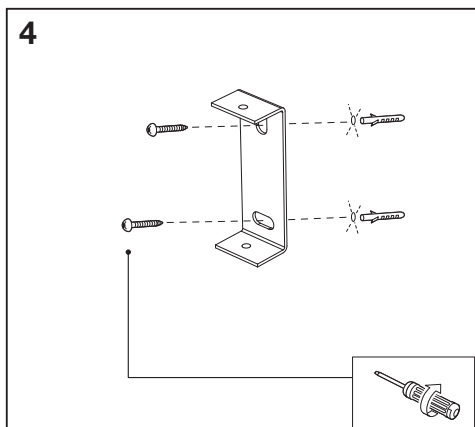
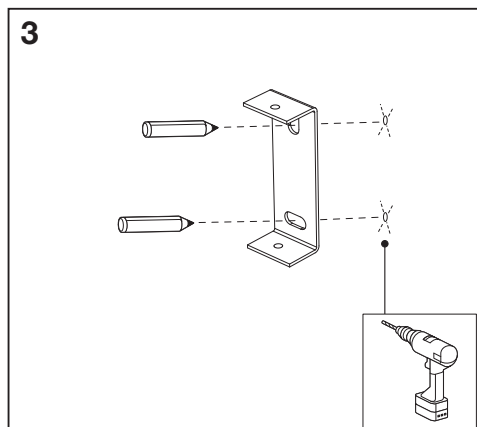
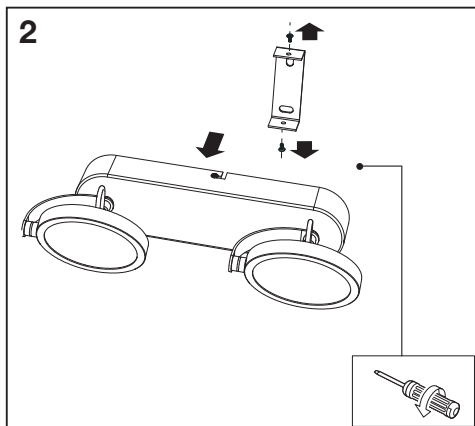
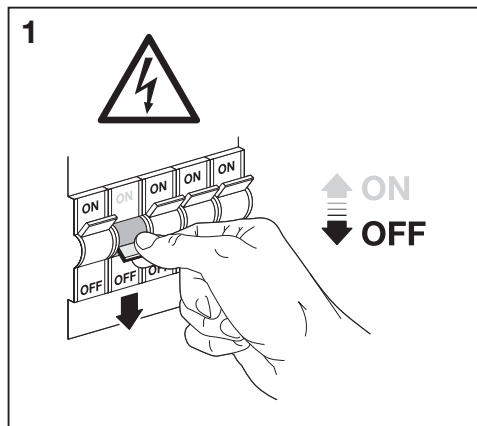
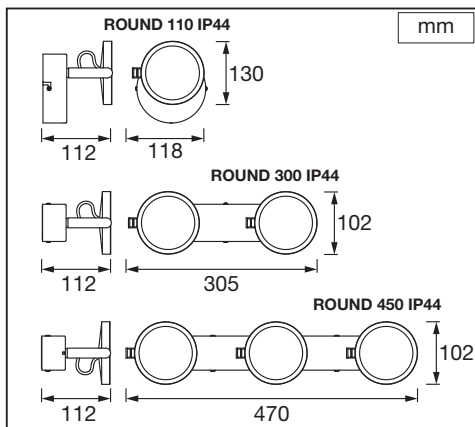
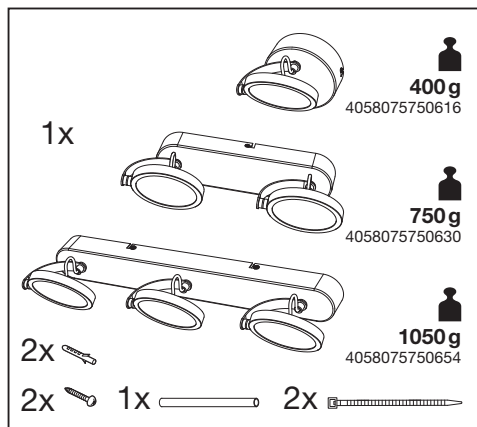
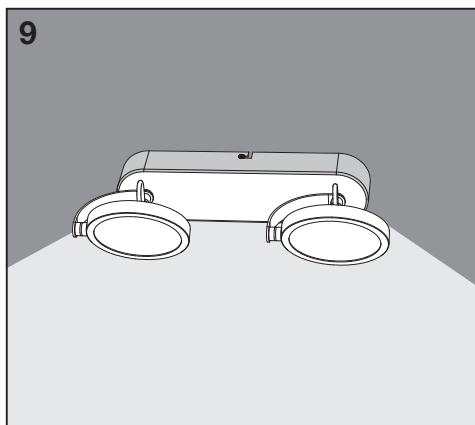
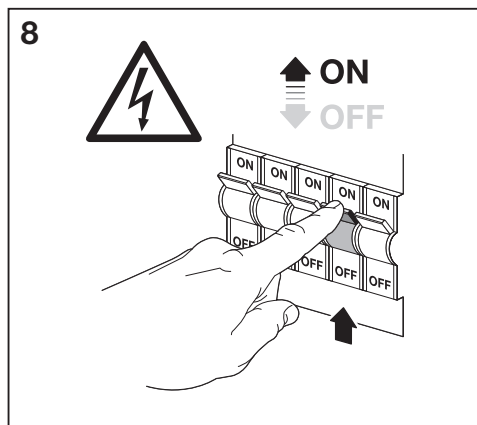
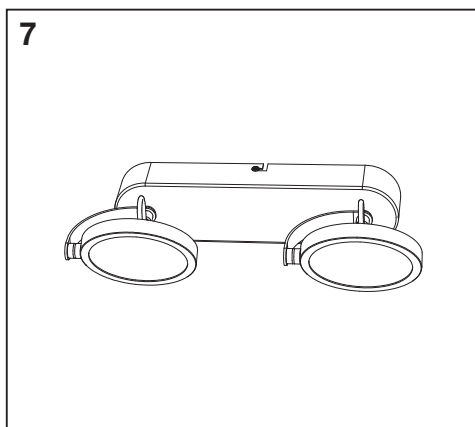
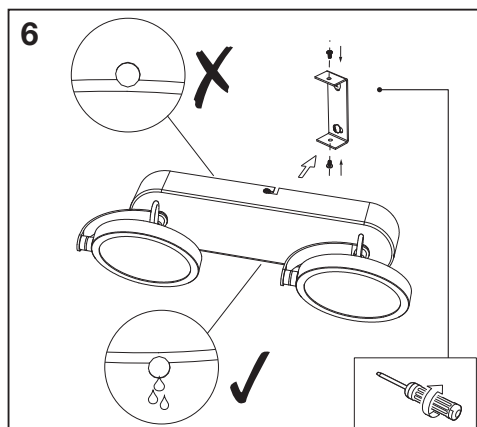
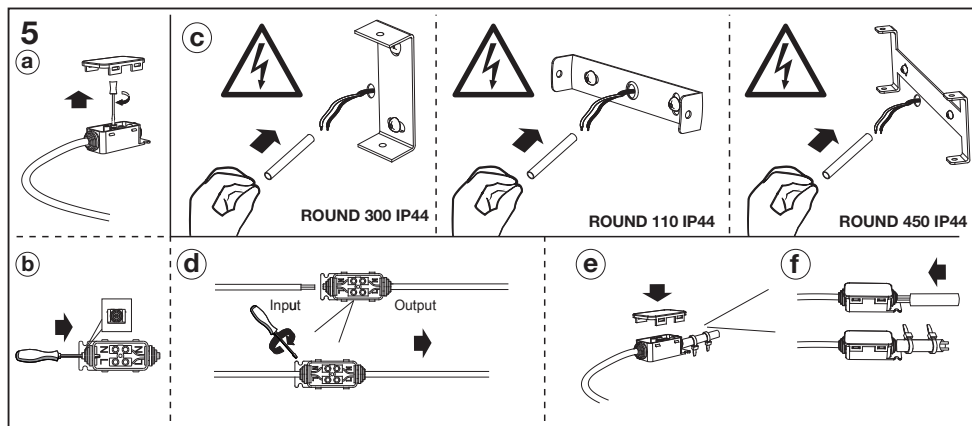



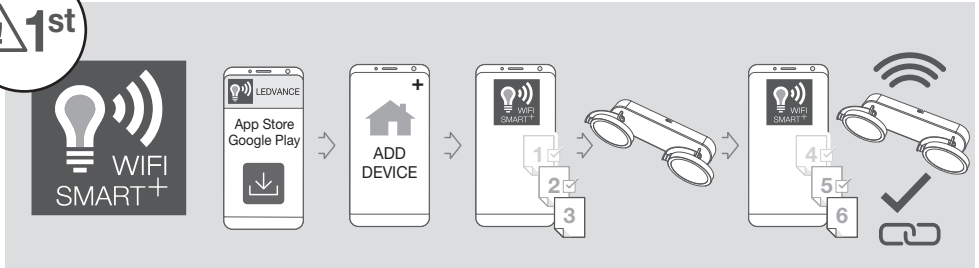

OPTIONAL

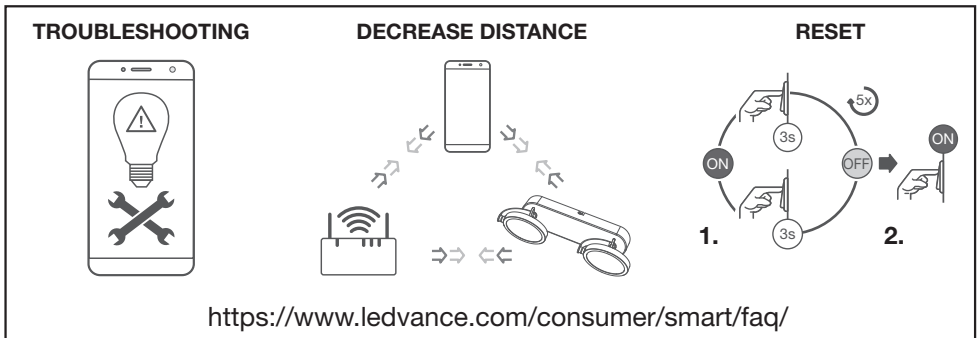
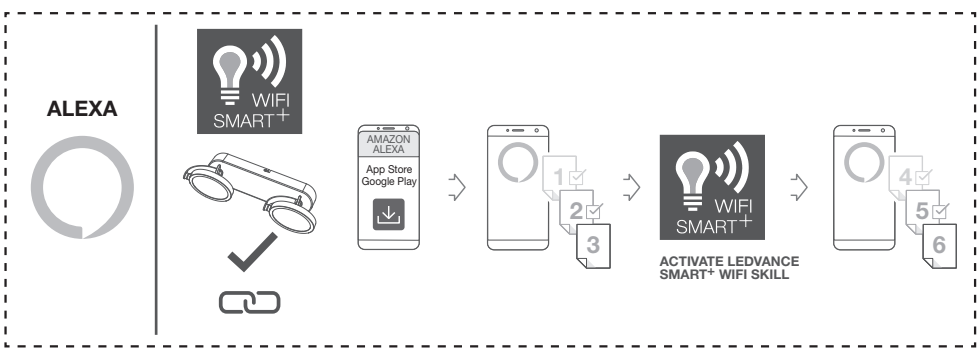
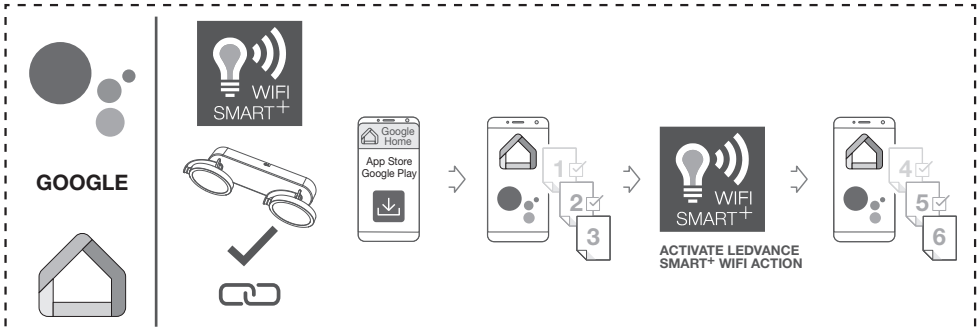

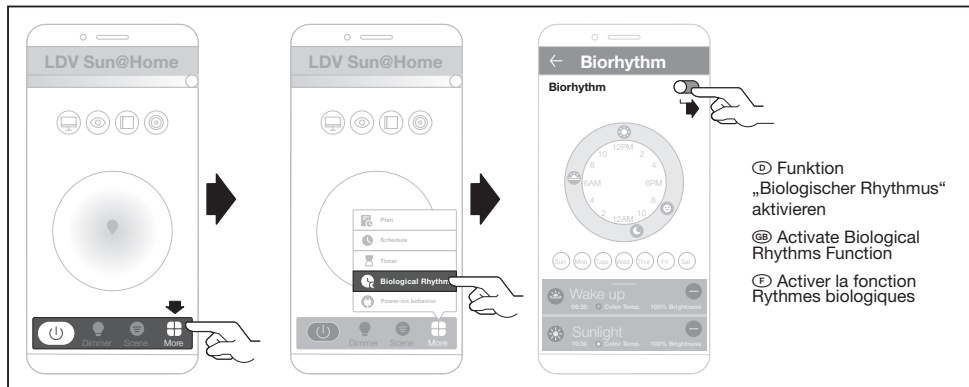

- ⓐ Funktion „Biologischer Rhythmus“ aktivieren
- ⓑ Activate Biological Rhythms Function
- ⓒ Activer la fonction Rythmes biologiques

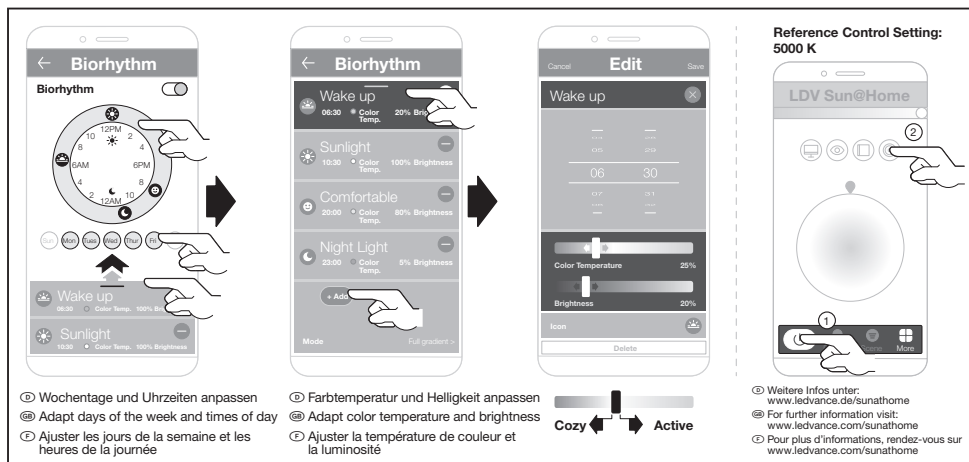

- ⓓ Wochentage und Uhrzeiten anpassen
- ⓔ Adapt days of the week and times of day
- ⓕ Ajuster les jours de la semaine et les heures de la journée
- ⓖ Farbtemperatur und Helligkeit anpassen
- ⓗ Adapt color temperature and brightness
- ⓓ Ajuster la température de couleur et la luminosité

Reference Control Setting: 5000 K

- ⓓ Weitere Infos unter: www.ledvance.de/sunathome
- ⓔ For further information visit: www.ledvance.com/sunathome
- ⓕ Pour plus d'informations, rendez-vous sur www.ledvance.com/sunathome

ⓐ Attivazione della funzione Ritmo biologico. Adattamento dei giorni della settimana e delle ore del giorno. Adattamento di temperatura del colore e luminosità. Per maggiori informazioni visitate il sito web: www.ledvance.com/sunathome

ⓑ Activar función "Ritmos biológicos". Adaptar días de la semana y horas del día. Adaptar temperatura cromática y brillo. Para mayor información, visite: www.ledvance.com/sunathome

ⓒ Ativar a Função de Ritmos Biológicos. Ajustar os dias da semana e as horas do dia. Ajustar a temperatura e o brilho da cor. Para mais informações, visite: www.ledvance.com/sunathome

ⓓ Ενεργοποίηση της λειτουργίας Biological Rhythms. Προσαρμογή ημερών της εβδομάδας και ωρών της ημέρας. Προσαρμογή θερμοκρασίας χρώματος και φωτεινότητας. Για περισσότερες πληροφορίες επισκεφθείτε: www.ledvance.com/sunathome

ⓔ Activer de fonction "Biological Rhythms". Pas de dagen van de week en de tijden aan. Pas de kleurtemperatuur en de helderheid aan. Bezoek: www.ledvance.com/sunathome

ⓕ Anpassa veckodagarna och tidpunkten på dygnet. Anpassa färgtemperaturen och ljusstyrkan. För ytterligare information besök: www.ledvance.com/sunathome

ⓖ Aktivni Biological Rhythms-toiminto. Säädä viikopäiviä ja kellonajaksi. Säädä värilämpötilaa ja kirkkautta. Jos kaipaat lisätietoja, käy sivuilla: www.ledvance.com/sunathome

ⓗ Aktivér Biological Rhythms-funktsjón. Tilpass ukedagur og klokkeslæt. Tilpass färgtemperatur og lysstyrke. For ytterligere informasjon vennligst gå inn på: www.ledvance.com/sunathome

ⓓ Aktivira funkcijon Biorhythmer. Anpassa funktionen Biological Rhythms. Juster ugedage og klokkeslæt. Juster farvetemperatur og lysstyrke. For yderligere oplysninger, gå til: www.ledvance.com/sunathome

ⓔ Zapné funkci Biological Rhythms. Nastavte dni v týždni a denní dobu. Nastavte barevnou teplotu a jas. Pro ďalší informácie kliknite na: www.ledvance.com/sunathome

ⓕ Aktivirujte funkciju Biological Rhythms. Nastrojite dni nedelje i vreme sutok. Nastrojite temperaturu boje i jarkost. Для получения дополнительной информации посетите веб-сайт: www.ledvance.com/sunathome

ⓖ Aktiválja a Biological Rhythms funkciót. Állítsa be a hét napját és a nap időszakát. Állítsa be a szín hőmérsékletet és fényerőt. Dövebb információ: www.ledvance.com/sunathome

ⓗ Włącz funkcje Biological Rhythms. Dostosuj dni tygodnia i godziny. Dostosuj temperaturę koloru i jasność. Aby uzyskać wię-

cej informacji, odwiedź stronę: www.ledvance.com/sunathome

ⓔ Aktivovat funkciju Biological Rhythms. Prispôsobit dni v týždni a časý dňa. Prispôsobit teplotu a jas farby. Pre viac informácií navštívte: www.ledvance.com/sunathome

ⓖ Aktivirajte funkciju Biological Rhythms. Prilagodite dan v tednu in uro. Prilagodite temperaturo barve in svetlosti. Več informacij je na voljo na: www.ledvance.com/sunathome

ⓓ Биологик Ритмилер işlevini etkinleştirin. Haftanın günlerini ve saatlerini ayarlayın. Renk sıcaklığı ve parlaklığını ayarlayın. Daha fazla bilgi için: www.ledvance.com/sunathome

ⓕ Aktivirajte funkciju Biological Rhythms. Prilagodite dane u tednu i vrijeme. Prilagodite temperaturu boje i svetlinu. Za dodatne informacije posjetite: www.ledvance.com/sunathome

ⓔ Aktivati funcția „Biological Rhythms”. Adaptați zilele săptămânii și orele zilei. Adaptați temperatura culorii și luminozitatea. Pentru mai multe informații vizitați: www.ledvance.com/sunathome

ⓖ Aktivirajte funkcijata Biological Rhythms. Адаптирайте дни от седмицата и часове от деня. Адаптирайте цветната температура и яркостта. За допълнителна информация посетете: www.ledvance.com/sunathome

ⓕ Aktivirajte funkciju Biological Rhythms funktion. Kohandage nädalapäevi ja kellaegude. Kohandage värvitemperatuuri ja heledust. Täpsem teavet: www.ledvance.com/sunathome

ⓓ Ілункіте функція „Biological Rhythms”. Nustatykite savaitės dienas ir paros laiką. Nustatykite spalvų temperatūrą ir ryškumą. Daugiau informacijos žr. puslapyje: www.ledvance.com/sunathome

ⓕ Aktivizēt funkciju "Biological Rhythms". Korīgēt nedēļas dienas un dienas laikus. Korīgēt krāsas siltumu un spilgtumu. Sīkākai informācijai skatiet: www.ledvance.com/sunathome

ⓖ Aktivirajte funkciju Biological Rhythms. Prilagodite dane u nedelji i vreme tokom dana. Prilagodite temperaturu boje i nivo osvetljenosti. Za više informacija posetite: www.ledvance.com/sunathome

ⓕ Aktivirajte funkciju Biological Rhythms. Налаштуйте дни тижня та час доби. Налаштуйте температуру кольору та яскравість. Для отримання додаткової інформації відвідайте веб-сайт: www.ledvance.com/sunathome

ⓖ Biological Rhythms функциясын іске қосыңыз. Апта күндерін және күн уақыттарын реттеңіз. Түс температурасын және жарықтың реттеңіз. Толығырақ ақпарат алу үшін кіріңіз: www.ledvance.com/sunathome

