

Product Data Sheet

GW10011M

CHORUSMART - Domestic range

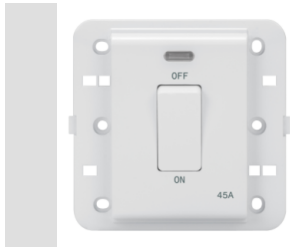

Wiring devices system characterized by its profile and shape inspired to the Chorus family feeling. Wide range of plates with an Italian design, articulated into two families, GEO and LUX cover plates, available in many materials and finishes. The range is available in three colors: glossy white, satin black, painted titanium and fits in 3x3 inches (1-gang) and 3x6 inches (2-gang) British Standard boxes. Range expandable thanks to the Chorus modular devices.

Category	DP switch	Type	Backlit
Button key	With diffuser	Symbol	45A
Colour	White	Description	2P - 45A
Voltage	250 V ac	Standard	EN 60669-1
Resistance at test voltage	2000 V at 50 Hz for 1 minute	Insulation resistance	> 5 MOhm
Wiring terminals	With screw	Prolonged operation switch (no.of position changes)	40.000 at In 250 V ac cosφ=0,6
Thermo-pressure with ball	125 °C	Glow Wire Test	850 °C
Terminal grip on cable traction	> 50 N	Terminal tightening capacity stranded cables (mm ²)	min. 6 - max. 16
Terminal tightening capacity solid cables (mm ²)	min. 6 - max. 16		

DIMENSIONAL

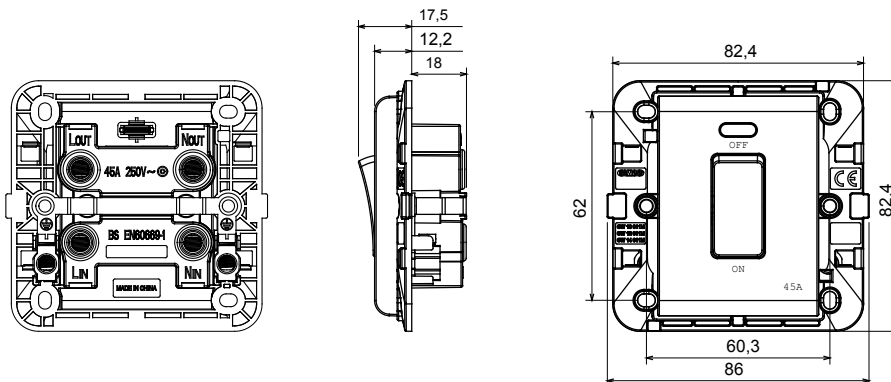

TECHNICAL SYMBOLOGY



STANDARDS/APPROVALS

