

# Modicon M580

## RIO Modules

### Installation and Configuration Guide

Original instructions

02/2022

EIO0000001584.12

# Legal Information

The Schneider Electric brand and any trademarks of Schneider Electric SE and its subsidiaries referred to in this guide are the property of Schneider Electric SE or its subsidiaries. All other brands may be trademarks of their respective owners.

This guide and its content are protected under applicable copyright laws and furnished for informational use only. No part of this guide may be reproduced or transmitted in any form or by any means (electronic, mechanical, photocopying, recording, or otherwise), for any purpose, without the prior written permission of Schneider Electric.

Schneider Electric does not grant any right or license for commercial use of the guide or its content, except for a non-exclusive and personal license to consult it on an "as is" basis. Schneider Electric products and equipment should be installed, operated, serviced, and maintained only by qualified personnel.

As standards, specifications, and designs change from time to time, information contained in this guide may be subject to change without notice.

To the extent permitted by applicable law, no responsibility or liability is assumed by Schneider Electric and its subsidiaries for any errors or omissions in the informational content of this material or consequences arising out of or resulting from the use of the information contained herein.

As part of a group of responsible, inclusive companies, we are updating our communications that contain non-inclusive terminology. Until we complete this process, however, our content may still contain standardized industry terms that may be deemed inappropriate by our customers.

# Table of Contents

Safety Information .....	7
Before You Begin .....	8
Start-up and Test.....	9
Operation and Adjustments.....	10
About the Book .....	11
Characteristics of Ethernet RIO Modules .....	14
Adapter Module Descriptions .....	14
LED Indicators on Adapter Modules.....	18
Adapter Ethernet Ports .....	21
RIO Network Cable Installation.....	23
Modicon X80 I/O Modules.....	24
Configuring the BMXNOM0200.4 Module in an X80 Drop.....	31
Standards and Certifications .....	34
Installation.....	35
Installing Modicon X80 Modules .....	35
Maximum Configuration in RIO Drops .....	35
Modicon X80 Backplane Considerations .....	36
Adapter and I/O Module Installation .....	38
Setting the Location of the Ethernet Remote I/O Drop.....	41
Remote I/O Infrastructure Cables .....	42
Cable Installation.....	42
Duplicate IP Address Checking.....	44
Loss of I/O Connection.....	45
Configuration and Programming with Control Expert.....	47
Creating a Control Expert Project .....	47
Configuring the RIO Drop.....	47
Control Expert Configuration for Ethernet RIO Modules.....	50
RSTP Bridge Configuration .....	50
SNMP Agent Configuration.....	51
Service Port Configuration.....	52
Control Expert Configuration for RIO Drops.....	53
Configuring Remote Drop Parameters.....	54

Time Stamping .....	56
Device DDT Names for M580 RIO Adapters .....	58
<b>Implicit and Explicit Messaging .....</b>	<b>64</b>
Explicit Messaging .....	64
Implicit I/O Exchanges .....	64
<b>Diagnostics .....</b>	<b>67</b>
Service Port Management.....	67
Service Port Configuration.....	67
Diagnostics Available through the CPU .....	68
System Diagnostics .....	68
Diagnostics Available through Modbus/TCP .....	70
Modbus Diagnostic Codes.....	70
Diagnostics Available through EtherNet/IP CIP Objects.....	71
About CIP Objects .....	71
Identity Object .....	72
Assembly Object .....	74
Connection Manager Object .....	75
Quality of Service (QoS) Object .....	77
TCP/IP Interface Object .....	79
Ethernet Link Object .....	81
EtherNet/IP Interface Diagnostics Object.....	85
I/O Connection Diagnostics Object.....	87
EtherNet/IP Explicit Connection Diagnostics Object .....	90
EtherNet/IP Explicit Connection Diagnostics List Object .....	92
RSTP Diagnostics Object.....	94
Service Port Control Object .....	97
SNTP Diagnostics Object.....	99
Ethernet Backplane Diagnostics Object.....	102
Diagnostics Available through Control Expert .....	105
Introduction to Control Expert Diagnostics .....	105
Displaying I/O Memory Consumption .....	105
<b>Firmware Update .....</b>	<b>107</b>
Firmware Update with Automation Device Maintenance .....	107
EIO Adapter Firmware Update with Unity Loader .....	107

---

Glossary.....	111
Index.....	117



# Safety Information

## Important Information

Read these instructions carefully, and look at the equipment to become familiar with the device before trying to install, operate, service, or maintain it. The following special messages may appear throughout this documentation or on the equipment to warn of potential hazards or to call attention to information that clarifies or simplifies a procedure.



The addition of this symbol to a “Danger” or “Warning” safety label indicates that an electrical hazard exists which will result in personal injury if the instructions are not followed.



This is the safety alert symbol. It is used to alert you to potential personal injury hazards. Obey all safety messages that follow this symbol to avoid possible injury or death.

### **DANGER**

**DANGER** indicates a hazardous situation which, if not avoided, **will result in** death or serious injury.

### **WARNING**

**WARNING** indicates a hazardous situation which, if not avoided, **could result in** death or serious injury.

### **CAUTION**

**CAUTION** indicates a hazardous situation which, if not avoided, **could result in** minor or moderate injury.

### **NOTICE**

**NOTICE** is used to address practices not related to physical injury.

## Please Note

Electrical equipment should be installed, operated, serviced, and maintained only by qualified personnel. No responsibility is assumed by Schneider Electric for any consequences arising out of the use of this material.

A qualified person is one who has skills and knowledge related to the construction and operation of electrical equipment and its installation, and has received safety training to recognize and avoid the hazards involved.

## Before You Begin

Do not use this product on machinery lacking effective point-of-operation guarding. Lack of effective point-of-operation guarding on a machine can result in serious injury to the operator of that machine.

### **▲ WARNING**

#### **UNGUARDED EQUIPMENT**

- Do not use this software and related automation equipment on equipment which does not have point-of-operation protection.
- Do not reach into machinery during operation.

**Failure to follow these instructions can result in death, serious injury, or equipment damage.**

This automation equipment and related software is used to control a variety of industrial processes. The type or model of automation equipment suitable for each application will vary depending on factors such as the control function required, degree of protection required, production methods, unusual conditions, government regulations, etc. In some applications, more than one processor may be required, as when backup redundancy is needed.

Only you, the user, machine builder or system integrator can be aware of all the conditions and factors present during setup, operation, and maintenance of the machine and, therefore, can determine the automation equipment and the related safeties and interlocks which can be properly used. When selecting automation and control equipment and related software for a particular application, you should refer to the applicable local and national standards and regulations. The National Safety Council's Accident Prevention Manual (nationally recognized in the United States of America) also provides much useful information.

In some applications, such as packaging machinery, additional operator protection such as point-of-operation guarding must be provided. This is necessary if the operator's hands and other parts of the body are free to enter the pinch points or other hazardous areas and



serious injury can occur. Software products alone cannot protect an operator from injury. For this reason the software cannot be substituted for or take the place of point-of-operation protection.

Ensure that appropriate safeties and mechanical/electrical interlocks related to point-of-operation protection have been installed and are operational before placing the equipment into service. All interlocks and safeties related to point-of-operation protection must be coordinated with the related automation equipment and software programming.

**NOTE:** Coordination of safeties and mechanical/electrical interlocks for point-of-operation protection is outside the scope of the Function Block Library, System User Guide, or other implementation referenced in this documentation.

## Start-up and Test

Before using electrical control and automation equipment for regular operation after installation, the system should be given a start-up test by qualified personnel to verify correct operation of the equipment. It is important that arrangements for such a check are made and that enough time is allowed to perform complete and satisfactory testing.

### **▲ WARNING**

#### **EQUIPMENT OPERATION HAZARD**

- Verify that all installation and set up procedures have been completed.
- Before operational tests are performed, remove all blocks or other temporary holding means used for shipment from all component devices.
- Remove tools, meters, and debris from equipment.

**Failure to follow these instructions can result in death, serious injury, or equipment damage.**

Follow all start-up tests recommended in the equipment documentation. Store all equipment documentation for future references.

#### **Software testing must be done in both simulated and real environments.**

Verify that the completed system is free from all short circuits and temporary grounds that are not installed according to local regulations (according to the National Electrical Code in the U.S.A, for instance). If high-potential voltage testing is necessary, follow recommendations in equipment documentation to prevent accidental equipment damage.

Before energizing equipment:

- Remove tools, meters, and debris from equipment.
- Close the equipment enclosure door.

- Remove all temporary grounds from incoming power lines.
- Perform all start-up tests recommended by the manufacturer.

## Operation and Adjustments

The following precautions are from the NEMA Standards Publication ICS 7.1-1995 (English version prevails):

- Regardless of the care exercised in the design and manufacture of equipment or in the selection and ratings of components, there are hazards that can be encountered if such equipment is improperly operated.
- It is sometimes possible to misadjust the equipment and thus produce unsatisfactory or unsafe operation. Always use the manufacturer's instructions as a guide for functional adjustments. Personnel who have access to these adjustments should be familiar with the equipment manufacturer's instructions and the machinery used with the electrical equipment.
- Only those operational adjustments actually required by the operator should be accessible to the operator. Access to other controls should be restricted to prevent unauthorized changes in operating characteristics.

# About the Book

## Document Scope

This document describes the adapter modules that can be used in X80 RIO drops.

This guide describes these adapter modules:

- BMECRA31210
- BMXCRA31210
- BMXCRA31200

**NOTE:** This book discusses BM•CRA312•1 adapter modules in M580 systems. To use Quantum 140CRA312•0 adapter modules in an M580 system, refer to chapter *Characteristics of Ethernet Remote I/O Modules* (see Quantum EIO, Remote I/O Modules, Installation and Configuration Guide).

These CPUs support Quantum RIO drops that include a 140CRA312•0 adapter module:

- BMEP584040 (version 2.10 or later)
- BMEP585040
- BMEP586040
- BMEH584040
- BMEH586040

**NOTE:** The specific configuration settings contained in this guide are for instructional purposes only. The settings required for your specific application can be different from the examples presented in this guide. To configure RIO drops in an M580 Hot Standby system, refer to the chapter *M580 (e)X80 RIO Drops* (see Modicon M580 Hot Standby, System Planning Guide for, Frequently Used Architectures).

**NOTE:** The architectures described in this document have been tested and validated in various scenarios. If you intend to use architectures different than the ones described in this document, test and validate them thoroughly before implementing.

## Validity Note

This document is valid for X80 RIO systems when used with EcoStruxure™ Control Expert 15.1 or later.

The technical characteristics of the devices described in the present document also appear online. To access the information online, go to the Schneider Electric home page [www.se.com/ww/en/download/](http://www.se.com/ww/en/download/).

The characteristics that are described in the present document should be the same as those characteristics that appear online. In line with our policy of constant improvement, we may revise content over time to improve clarity and accuracy. If you see a difference between the document and online information, use the online information as your reference.

## Related Documents

Title of documentation	Reference number
Electrical installation guide	EIGED306001EN (English)
Modicon M580, M340, and X80 I/O Platforms, Standards and Certifications	EIO0000002726 (English), EIO0000002727 (French), EIO0000002728 (German), EIO0000002730 (Italian), EIO0000002729 (Spanish), EIO0000002731 (Chinese)
Modicon M580 Standalone, System Planning Guide for Frequently Used Architectures	HRB62666 (English), HRB65318 (French), HRB65319 (German), HRB65320 (Italian), HRB65321 (Spanish), HRB65322 (Chinese)
Modicon M580, System Planning Guide for Complex Topologies	NHA58892 (English), NHA58893 (French), NHA58894 (German), NHA58895 (Italian), NHA58896 (Spanish), NHA58897 (Chinese)
Modicon M580 Hot Standby, System Planning Guide for Frequently Used Architectures	NHA58880 (English), NHA58881 (French), NHA58882 (German), NHA58883 (Italian), NHA58884 (Spanish), NHA58885 (Chinese)
Modicon M580, Hardware, Reference Manual	EIO0000001578 (English), EIO0000001579 (French), EIO0000001580 (German), EIO0000001582 (Italian), EIO0000001581 (Spanish), EIO0000001583 (Chinese)
Modicon X80 Racks and Power Supplies, Hardware, Reference Manual	EIO0000002626 (English), EIO0000002627 (French), EIO0000002628 (German), EIO0000002630 (Italian), EIO0000002629 (Spanish), EIO0000002631 (Chinese)
Modicon X80, BMXERT1604T Time Stamp Module, User Guide	EIO0000001121 (English), EIO0000001122 (French), EIO0000001123 (German), EIO0000001125 (Italian), EIO0000001124 (Spanish), EIO0000001126 (Chinese)
Modicon X80, BMXNOM0200 Serial Link Module, User Manual	EIO0000002696 (English), EIO0000002697 (French), EIO0000002698 (German), EIO0000002699 (Italian), EIO0000002700 (Spanish), EIO0000002701 (Chinese)
Quantum EIO, Remote I/O Modules, Installation and Configuration Guide	S1A48978 (English), S1A48981 (French), S1A48982 (German), S1A48983 (Italian), S1A48984 (Spanish), S1A48985 (Chinese)
Quantum using EcoStruxure™ Control Expert, Hardware Reference Manual	35010529 (English), 35010530 (French), 35010531 (German), 35013975 (Italian), 35010532 (Spanish), 35012184 (Chinese)

Title of documentation	Reference number
Modicon M340 for Ethernet, Communications Modules and Processors, User Manual	31007131 (English), 31007132 (French), 31007133 (German), 31007494 (Italian), 31007134 (Spanish), 31007493 (Chinese)
System Time Stamping, User Guide	EIO0000001217 (English), EIO0000001707 (French), EIO0000001708 (German), EIO0000001710 (Italian), EIO0000001709 (Spanish), EIO0000001711 (Chinese)
EcoStruxure™ Control Expert, Applicative Time Stamping, User Guide	EIO0000001268 (English), EIO0000001702 (French), EIO0000001703 (German), EIO0000001705 (Italian), EIO0000001704 (Spanish), EIO0000001706 (Chinese)
EcoStruxure™ Control Expert, Program Languages and Structure, Reference Manual	35006144 (English), 35006145 (French), 35006146 (German), 35013361 (Italian), 35006147 (Spanish), 35013362 (Chinese)
EcoStruxure™ Control Expert, UnityLL984, Block Library	EIO0000000550 (English), EIO0000000807 (French), EIO0000000808 (German), EIO0000000809 (Italian), EIO0000000810 (Spanish), EIO0000000811 (Chinese)

You can download these technical publications, the present document and other technical information from our website [www.se.com/en/download/](http://www.se.com/en/download/).

# Characteristics of Ethernet RIO Modules

## Introduction

This chapter describes the adapter modules that can be used in the remote drops of an X80 system. Specifically, these modules are:

- BMECRA31210
- BMXCRA31210
- BMXCRA31200

This chapter includes physical characteristics, port descriptions, and agency specifications for these modules.

**NOTE:** This book describes the BM• CRA 312 •1 adapter modules. To use Quantum 140 CRA adapter modules in M580 systems, refer to the Quantum RIO Modules guide (see Quantum EIO, Remote I/O Modules, Installation and Configuration Guide).

## Adapter Module Descriptions

### Introduction

An RIO drop consists of one or two racks of Modicon X80 I/O modules and/or third-party PME SWT 0100 modules. An RIO drop is connected to the daisy-chain loop on which the Ethernet RIO network resides. Each remote drop contains one BM•CRA312•0 adapter module. Each rack in a remote drop contains its own power supply module.

Remote adapter modules are available as Ethernet BME and X Bus BMX communicators. To use X80 I/O modules that require Ethernet, choose a BME-style adapter module. If your X80 I/O uses only X Bus for backplane communication, then you can use a BMX-style adapter module.

The adapter modules are:

Adapter	Description
X80 standard EIO adapter	<p>The BMXCRA31200 is a basic adapter module that supports X Bus communications across the remote backplane, but not Ethernet.</p> <p>It does not support:</p> <ul style="list-style-type: none"> <li>• an extension rack</li> <li>• special-purpose or Ethernet I/O modules</li> <li>• native timestamping</li> <li>• service port</li> <li>• I/O to be solved more than once per logic scan in the remote drop. (It only handles MAST, page 64 tasks. Your application cannot assign FAST and AUX tasks in it.</li> </ul>
X80 performance EIO adapter	<p>The BMXCRA31210 adapter module supports X Bus communications across the remote backplane, but not Ethernet.</p> <p>It supports:</p> <ul style="list-style-type: none"> <li>• an extension rack</li> <li>• special-purpose modules</li> <li>• native timestamping</li> <li>• service port</li> <li>• MAST, page 64, FAST, page 65, and AUX0, page 65/AUX1, page 65 task customization of the Ethernet I/O scanner service</li> </ul>
eX80 performance EIO adapter	<p>The BMECRA31210 adapter supports Ethernet and X Bus communications across the remote backplane. This adapter needs to be installed in an Ethernet backplane.</p> <p>It supports:</p> <ul style="list-style-type: none"> <li>• the capabilities of a BMXCRA31210 adapter</li> <li>• Ethernet I/O modules on rack slots connected to the Ethernet backplane in the remote drop, such as the BMEAHI0812 and BMEAHO0412 HART-compatible analog modules, and PME SWT 0100 weighing module</li> </ul>

**NOTE:** You can also use these BMECRA312•0 eX80 EIO adapter modules in a Quantum EIO system with a high-end CPU (140CPU6•••• (see Quantum using EcoStruxure™ Control Expert, Hardware, Reference Manual)) configured on the local rack.

## RIO Drop Maximum Configuration

The maximum number of channels in an RIO drop depends on the eX80 EIO adapter module:

EIO adapter	Maximum number of Channels			
	Discrete	Analog	Expert	Sensor bus
BMXCRA31200	128	16	–	–
BMXCRA31210	1024	256	36	2
BMECRA31210	1024	256	36	2

**NOTE:** The number of available channels could differ from the maximum values shown because the values depend on the CPU reference and the other modules in the same drop. Refer to the description of [Modicon X80 I/O Modules](#), page 24.

To configure Quantum RIO drops, refer to the Quantum EIO installation and configuration guide.

## Functionality

The adapters exchange data through the Ethernet I/O scanner service in the CPU on the main local rack of your PAC system:

- The input data from the RIO drop is collected and published to the I/O scanner.
- The output modules are updated with the data received from the I/O scanner.
- The protocol used for exchange is EtherNet/IP.
- The exchanges are deterministic, which means that the RIO logic is scanned regularly in a scheduled and predictable manner.

**NOTE:** Refer to your system hardware reference manual to select a CPU that supports the Ethernet I/O scanner service.



## External Features

These adapter modules have the same dimensions and installation constraints as the other modules in the Modicon X80 product line:

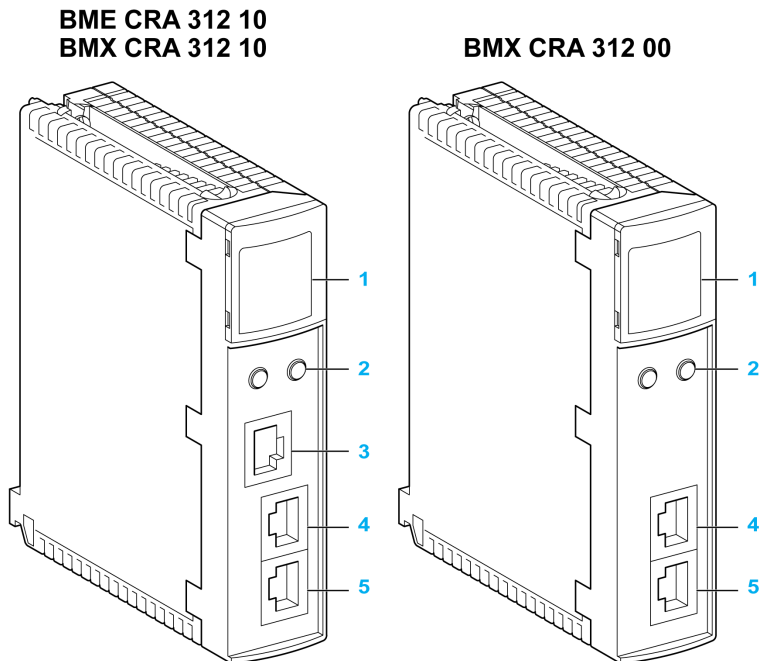

1 LED display

2 rotary switches

3 SERVICE port (ETH 1)

4 DEVICE NETWORK port (ETH 2)

5 DEVICE NETWORK port (ETH 3)

**NOTE:** Refer to the LEDs, page 18.

The Ethernet ports are labeled on the front of the modules.

**NOTE:** Insert dust covers into the unused Ethernet ports on the adapter modules:

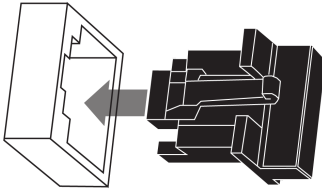

## Ruggedized Versions

The BMECRA31210C and BMXCRA31210C (coated) equipment are the ruggedized versions of the respectively BMECRA31210 and BMXCRA31210 (standard) equipment. They can be used at standard temperatures and in harsh chemical environments.

For more information, refer to chapter *Installation in More Severe Environments* (see Modicon M580, M340, and X80 I/O Platforms, Standards and Certifications).

## Altitude Operating Conditions

The characteristics apply to the eX80 EIO adapter modules BM•CRA312•0(C) for use at altitude up to 2000 m (6560 ft). When the modules operate above 2000 m (6560 ft), apply additional derating.

For detailed information, refer to chapter *Operating and Storage Conditions* (see Modicon M580, M340, and X80 I/O Platforms, Standards and Certifications).

## LED Indicators on Adapter Modules

### Display

The LEDs are on the front of the adapter module:



## Indications

**NOTICE**

**UNINTENDED EQUIPMENT BEHAVIOR**

Confirm that each module has a unique IP address. Duplicate IP addresses can cause unpredictable module/network behavior.

**Failure to follow these instructions can result in equipment damage.**

LED conditions:

Module State <sup>(1)</sup>	Description	Run	IO	MS (Module Status)		NS (Network Status)	
		Green	Red	Green	Red	Green	Red
power-up sequence	Order of LEDs blinking	1	2	3	4	5	6
not configured	IP address not valid	-	-	flashing	off	off	off
	valid IP address, but invalid configuration	off	off	flashing	off	flashing	off
configured	no external error detected	flashing	off	-	-	flashing	off
	external error detected	flashing	on	-	-	flashing	off
I/O data communication established	STOP	flashing	(NOTE 1)	on	off	on	off
	RUN	on	(NOTE 2)	on	off	on	off
detected error states	recoverable error	-	-	off	flashing	-	-
	nonrecoverable error	flashing	on	off	on	-	-
	One or more owner connections has timed out	-	-	-	-	-	flashing
	duplicate IP address	-	-	-	-	off	on

Module State <sup>(1)</sup>	Description	Run	IO	MS (Module Status)		NS (Network Status)	
		Green	Red	Green	Red	Green	Red
during OS firmware update		flashing	off	off	on	off	on
<p>(1) For more information about the module states, refer to your system hardware reference manual.</p> <p><b>NOTE 1</b> (STOP state):</p> <ul style="list-style-type: none"> <li>on: An input or output is a detected error that originates in a module, or a channel configuration or a channel configuration error has been detected.</li> <li>off: Operations are normal.</li> </ul> <p><b>NOTE 2</b> (RUN state):</p> <ul style="list-style-type: none"> <li>on: External error is detected.</li> <li>off: External error is not detected.</li> </ul>							

### Ethernet Port Indications

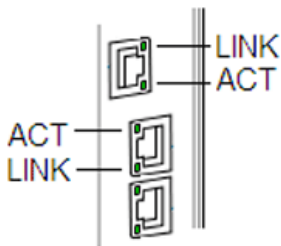

These LEDs report the status of the Ethernet port:

Name	Color	Status	Description
LINK	green	on	100 Mbps link detected
	yellow	on	10 Mbps link detected
	-	off	no detected link
ACT	green	blinking	active Ethernet link (transmit or receive)
	-	off	inactive Ethernet link

# Adapter Ethernet Ports

## Ethernet Port Descriptions

Two of the Ethernet ports allow implicit I/O exchanges with the I/O scanner in the CPU. (An implicit I/O exchange has a maximum frame size of 1400 bytes.) The ports can be implemented alone or in redundant mode.

You can use a maximum of 31 adapters in a single Ethernet RIO network depending on the CPU used. For network topology planning, refer to the planning guide for your system.

These adapter modules have two or three 10/100 Base-T Ethernet ports:

Port	Description
SERVICE	<p>The SERVICE port allows the diagnosis of Ethernet device network ports and provides access to external tools and devices (Control Expert, ConneXium Network Manager, HMI, and so forth). The port supports these modes:</p> <ul style="list-style-type: none"> <li>• access port (default): This mode supports Ethernet communications.</li> <li>• port mirroring: In this mode, data traffic from one of the other 2 ports is copied to this port. This allows a connected management tool to monitor and analyze the port traffic.</li> <li>• disabled</li> </ul> <p><b>NOTE:</b></p> <ul style="list-style-type: none"> <li>• The BMXCRA31200 does not have a SERVICE port.</li> <li>• You can configure the SERVICE port either ONLINE or OFFLINE.</li> <li>• In port mirroring mode, the SERVICE port acts like a read-only port. That is, you cannot access devices (ping, connection to Control Expert, and so forth) through the SERVICE port.</li> </ul> <p>Refer to <i>Service Port Configuration</i>, page 52.</p>
DEVICE NETWORK	<p>The DEVICE NETWORK copper ports are used to put the drop on the simple daisy chain loop. They provide:</p> <ul style="list-style-type: none"> <li>• connections for RIO communications</li> <li>• cable redundancy</li> </ul>

### CAUTION

#### **ETHERNET CONNECTION NON-OPERATIONAL**

Do not connect a device with a speed in excess of 100 Mbit/s to any adapter port.

**Failure to follow these instructions can result in injury or equipment damage.**

Connecting a device with a speed in excess of 100 Mbit/s, the Ethernet link may not be established between the device and the module through its port.

## BMECRA31210 Keying Pin

The BMECRA31210 adapter is designed to be installed on an Ethernet backplane in the main remote rack. The adapter supports the Modicon X80 I/O and partner modules with both Ethernet and X Bus connections. The two bus connectors are shown in items 1 and 2 below.

The adapter also has a keying pin (item 3 below) to keep it from being installed on a BMEXBP PV 01 backplane.

Rear view of the adapter module:

**BME CRA 312 10**

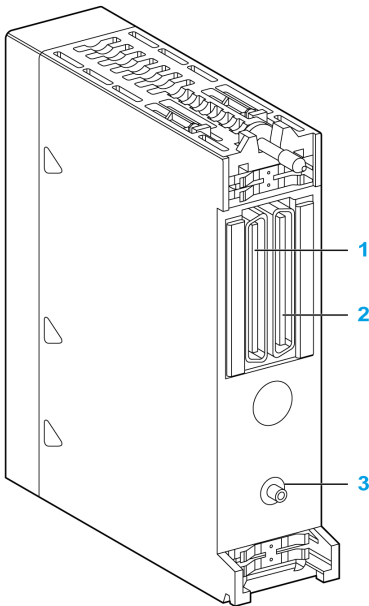

1	X Bus backplane connector
2	Ethernet backplane connector
3	Keying pin

# RIO Network Cable Installation

## Introduction

Use a daisy chain loop network configuration that implements the RSTP service to establish redundant communications with at least one of the two physical paths between:

- the I/O scanner
- the adapter modules at each remote drop, dual ring switches (DRSs), or any product that has the capacity to be RIO scanned

For network topology planning, refer to your system planning guide.

**NOTE:** Fiber optic ports are not available on the adapter modules. For fiber optic support use either a BMXNRP020• optic fiber conversion module or a pair of DRSs.

## RIO Simple Daisy Chain Loop

The CPU supports communications with RIO drops in a daisy chain loop:

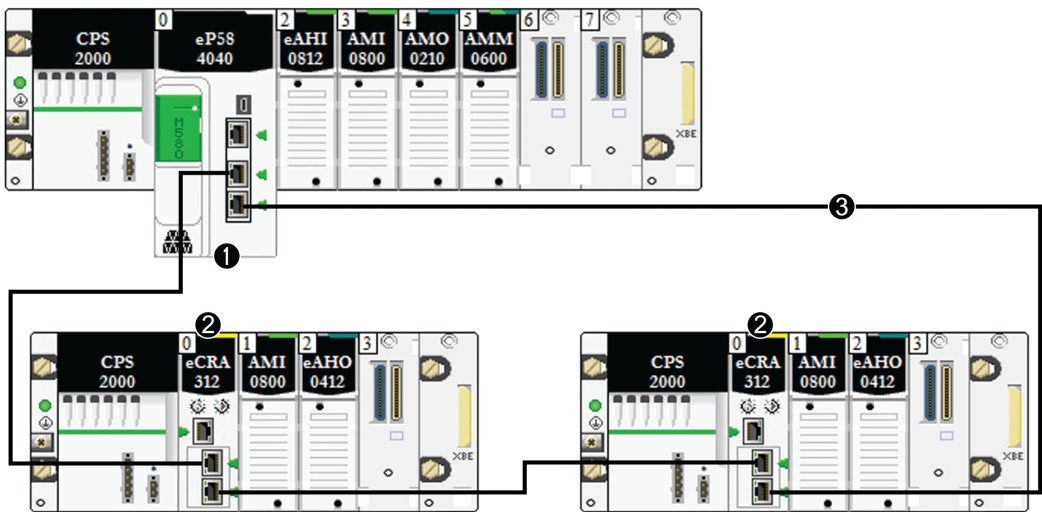

1 main local rack with a BME•58•40 CPU with the Ethernet I/O scanner service

2 X80 RIO drops with a BM•CRA312•0 adapter module

3 the daisy chain loop

# Modicon X80 I/O Modules

## Introduction

The following I/O modules can be mounted in local racks or RIO drops in an M580 system.

Unless otherwise noted in the following tables, X80 I/O modules are supported on the following racks in RIO drops:

- an X Bus rack with a BMXCRA312•0 X80 EIO adapter module
- an Ethernet rack with a BMECRA312•0 eX80 EIO adapter module

Some of these modules also contain embedded web pages that can be used for configuration and diagnostics. Web page descriptions are provided in the appropriate product documentation and in Control Expert help.

**NOTE:** Conformally coated (hardened H) versions of many of these modules are also available. Refer to the specifications for hardened equipment in the *Modicon M580, M340, and X80 I/O Platforms, Standards and Certifications* guide.

## Modicon X80 Analog Modules

Modules that require Ethernet across the backplane can be installed only in main local or remote local racks. They cannot be installed in extended racks.

**NOTE:** Debug screens are not available for analog modules in RIO drops and the parameters can't be changed (Alignment, Filter, Offset...). If you need to modify the parameters, use the analog modules in local or local extended racks.

These analog I/O modules are supported in Modicon X80 local racks containing a CPU and RIO drops:

Type of Module	Module	Installation on...			
		Main Local Rack	Extended Local Rack	Main Remote Rack	Extended Remote Rack
input	BMXAMI••••	+(3)	+(3)	+	+
	BMXART••••(1)	+(3)	+(3)	+	+
	BMEAHI0812(2)	+(3)	-	+(4)	-
output	BMXAMO••••	+(3)	+(3)	+	+
	BMEAHO0412(2)	+(3)	-	+(3)	-



Type of Module	Module	Installation on...			
		Main Local Rack	Extended Local Rack	Main Remote Rack	Extended Remote Rack
input/output	BMXAMM0600	+(3)	+(3)	+	+
<p>(1) The FAST task is not supported.</p> <p>(2) These modules require an Ethernet backplane.</p> <p>(3) Not supported in an M580 Hot Standby system.</p> <p>(4) When installed in an RIO drop, use a <b>BM•CRA31210</b> (e)X80 performance EIO adapter module. These modules are <u>not</u> compatible with <b>BM•CRA31200</b> (e)X80 standard EIO adapter modules.</p> <p>+ Allowed</p> <p>- Not allowed</p>					

**NOTE:** A maximum of 2 analog modules are allowed on an RIO drop that contains a BMXCRA31200.2 X80 EIO adapter module. These analog modules can have a maximum of 8 channels (16 for analog I/O modules).

When the following modules are used in a local rack (containing a CPU) and RIO drops, they require these versions:

Module	Product Version	Software Version
BMXAMI0410	PV5	SV1.1
BMXAMM0600	PV5 or later	SV1.2
BMXAMO0210	PV7 or later	SV1.1
BMXART0414	PV5, PV6	SV2.0
	PV7	SV2.1
BMXART0814	PV3, PV4	SV2.0
	PV5 or later	SV2.1

**NOTE:** Schneider Electric recommends that you upgrade the modules with the latest available software version. (It is not necessary to update a BMXART0414 module, V2.1 or later, because it works correctly with a BM•CRA312•0 X80 EIO adapter module).

## Modicon X80 Discrete Modules

**NOTE:** In the CPU configuration screen in Control Expert, you can configure a digital I/O module channel as a **RUN/STOP input** by selecting this check box. This can be performed on a local I/O channel in topological I/O data type only. (This configuration is not available in Hot Standby systems).

These discrete I/O modules are supported in Modicon X80 local racks containing a CPU and RIO drops:

Type of Module	Module	Installation on...			
		Main Local Rack	Extended Local Rack	Main Remote Rack	Extended Remote Rack
input	BMXDAI****	+(2)	+(2)	+	+
	BMXDDI****(1)	+(2)	+(2)	+	+
output	BMXDAO****	+(2)	+(2)	+	+
	BMXDDO****	+(2)	+(2)	+	+
	BMXDRA****(1)	+(2)	+(2)	+	+
	BMXDRC****	+(2)	+(2)	+	+
input/output	BMXDDM****	+(2)	+(2)	+	+

**(1)** Before installation of I/O modules that use a 125 Vdc power supply, refer to the temperature derating information in I/O module hardware guides for your platform.

**(2)** Not supported in an M580 Hot Standby system.

+ Allowed

- Not allowed

**NOTE:** Schneider Electric recommends that you upgrade the modules with the latest available software version. (It is not necessary to update a BMXART0414 module, V2.1 or later, because it works correctly with a BM•CRA312•0 X80 EIO adapter module.)

## Communication Modules

**NOTE:** The maximum number of communication modules you can install on the local rack depends upon the CPU you choose (see Modicon M580 Standalone, System Planning Guide for, Frequently Used Architectures).

These communication modules are supported in M580 local racks (containing a CPU with Ethernet I/O communication server service) and RIO drops that contain a BM•CRA312•0 X80 EIO adapter module:

Module	Comment	Installation on...			
		Main Local Rack	Extended Local Rack	Main Remote Rack	Extended Remote Rack
BMXNOM0200 <sup>(1)</sup>	<p>Only MAST task is supported.</p> <p>Additional restrictions are described in chapter <i>BMXNOM0200 Limitation and Implementation Rules</i> (see Modicon X80, BMXNOM0200 Serial Link Module, User Manual).</p> <p>Refer to the instruction to configure the BMXNOM0200 module in an X80 RIO drop, page 31</p>	+ <sup>(3)</sup>	+ <sup>(3)</sup>	+ <sup>(4)</sup>	+
BMXNOR0200	<p>Only MAST task is supported.</p>	+ <sup>(3)</sup>	+ <sup>(3)</sup>	-	-
BMXNGD0100	<p>Dedicated to global data.</p> <p>For configuration details, refer to the BMXNOE0100 user guide (3100713*) (see Modicon M340 for Ethernet, Communications Modules and Processors, User Manual). The BMXNGD0100 module has the same global data functionality as the BMXNOE0100, but it does not support these services: I/O scanning, address server, time synchronization, bandwidth monitoring, or web pages.</p>	+ <sup>(3)</sup>	-	-	-
BMXEIA0100 <sup>(1)</sup>	<p>Only MAST task is supported.</p> <p>A maximum of 16 AS-i modules in an M580 configuration is allowed.</p> <p>A maximum of two AS-i modules on an RIO drop containing a BM•CRA3•• X80 EIO adapter is allowed.</p> <p>The following maximum number of AS-i modules on a local rack containing one of the following CPUs is allowed.</p> <ul style="list-style-type: none"> <li>• BMEP581020: two</li> <li>• BMEP582020: four</li> <li>• BMEP582040: four</li> <li>• BMEP583020: six</li> <li>• BMEP583040: six</li> <li>• BMEP584020: eight</li> <li>• BMEP584040: eight</li> <li>• BMEP585040: eight</li> <li>• BMEP586040: eight</li> </ul> <p>A maximum of 16 AS-i modules is allowed in RIO drops in an M580 system that uses BME•585040 or BME•586040 CPUs.</p>	+ <sup>(3)</sup>	+ <sup>(3)</sup>	+ <sup>(4)</sup>	+

Module	Comment	Installation on...			
		Main Local Rack	Extended Local Rack	Main Remote Rack	Extended Remote Rack
BMECXM0100 <sup>(2)</sup>	Connects an M580 CPU on an Ethernet network to CANopen fieldbus devices.  Requires an Ethernet backplane.	+ <sup>(3)</sup>	-	+	-
BMXNRP0200, BMXNRP0201	Fiber cable conversion	+	+	+	+
<p>(1) If a BMXNOM0200 module and a BMXEIA0100 module are included on the same RIO drop, only one BMXNOM0200 module and two BMXEIA0100 modules maximum are allowed.</p> <p>(2) Compatible with M580 CPUs V2.00 or later only.</p> <p>(3) Not supported in an M580 Hot Standby system.</p> <p>(4) When installed in an RIO drop, use a <b>BM•CRA31210</b> (e)X80 performance EIO adapter module. These modules are <u>not</u> compatible with <b>BM•CRA31200</b> (e)X80 standard EIO adapter modules.</p> <p>+ Allowed - Not allowed</p>					

## Counting Modules

**NOTE:** When installed in an RIO drop, use a **BM•CRA31210** (e)X80 performance EIO adapter module. These modules are not compatible with **BM•CRA31200** (e)X80 standard EIO adapter modules.

**NOTE:** I/O event tasks are supported only through topological data type, not through device DDT.

These counting modules are supported in M580 local racks (containing a CPU with Ethernet I/O communication server service) and RIO drops that contain a **BM•CRA31210** (e)X80 EIO performance adapter module:

Module	Comment	Installation on...			
		Main Local Rack	Extended Local Rack	Main Remote Rack	Extended Remote Rack
BMXEHC0200		+(1)	+(1)	+	+
BMXEHC0800	<p>When configuring a BMXEHC0800 module, the dual phase counting mode function <b>is not</b> available in X80 EIO drops or when using device DDT in local racks.</p> <p>When configuring a BMXEHC0800.2 module the dual phase counting mode function <b>is</b> available in X80 EIO drops and when using device DDT in local racks. In this case the event feature is not available.</p>	+(1)	+(1)	+	+
BMXEAE0300	<p>In RIO drops:</p> <ul style="list-style-type: none"> <li>Events are not supported.</li> <li>If events are needed, move the module to the local rack.</li> <li>A maximum of 36 channels can be configured.</li> </ul>	+(1)	+(1)	+	+
<p><b>(1)</b> Not supported in an M580 Hot Standby system.</p> <p>+ Allowed</p> <p>- Not allowed</p>					

When the following modules are used in a local rack (containing a CPU) and RIO drops, they require these versions:

Module	Product Version	Software Version
BMXEHC0200	PV3	SV1.1
BMXEHC0800	PV3	SV1.1

**NOTE:** Schneider Electric recommends that you upgrade the modules with the latest available software version.

### Intelligent and Special Purpose Modules

These intelligent/special purpose modules are supported in M580 local racks (containing a CPU with Ethernet I/O communication server service) and RIO drops that contain a BM•CRA312•0 X80 EIO adapter module:

Module	Comment	Installation on...			
		Main Local Rack	Extended Local Rack	Main Remote Rack	Extended Remote Rack
BMXERT1604T	Limitations for the time stamping module are described in chapter <i>Compatibility and Limitations</i> (see Modicon X80, BMXERT1604T/H Time Stamp Module, User Manual).	+(2)	+(2)	+(3)	+
PMXNOW0300	wireless multi-function access point/bridge	+(2)	+(2)	+	+
PMXCDA0400	diagnostic (machines, processes, and infrastructures)	+(2)	+(2)	+	+
PMESWT0100 <sup>(1)</sup>	This is an Ethernet weighing transmitter (1 channel) and requires an Ethernet backplane.	+(2)	-	+	-
PMEUCM0302	universal communication This requires an Ethernet backplane.	+(2)	-	+	-
PMEPXM0100	Profibus DP/DPV1 master module that requires an Ethernet backplane	+(4)	+(4)	+(5)	+(5)
BMENOR2200H	Modicon M580 BMENOR2200H Advanced RTU Module				
BMENUA0100	Ethernet communication module with embedded OPC UA server	+	-	-	-
<p>(1) Scanned as a device by the DIO scanner in the CPU.</p> <p>(2) Not supported in an M580 Hot Standby system.</p> <p>(3) When installed in an RIO drop, use a <b>BM•CRA31210</b> (e)X80 performance EIO adapter module. These modules are <u>not</u> compatible with <b>BM•CRA31200</b> (e)X80 standard EIO adapter modules.</p> <p>(4) Not supported on a local rack in an M580 standalone system.</p> <p>(5) Not supported on an EIO remote drop in an M580 Hot Standby system.</p> <p>+ Allowed</p> <p>- Not allowed</p>					

# Configuring the BMXNOM0200.4 Module in an X80 Drop

## Introduction

In X80 EIO drops, Modbus slave messages received by the BMXNOM0200 module are transferred to the X80 EIO adapter module (BMXCRA31210 or BMECRA31210). The adapter module forwards the message to the CPU.

To configure the BMXNOM0200 as a Modbus RS-485 RTU slave in an X80 drop, use these firmware versions and Control Expert **Hardware Catalog** devices:

Module	Firmware version	Control Expert Hardware Catalog device
BMXNOM0200	SV ≥ V1.5	BMXNOM0200.4
BMXCRA31210 or BMECRA31210	SV ≥ V2.14	BMXCRA31210 (SV >=2.10) or BMECRA31210 (SV >=2.10)

The BMXNOM0200 module is configured differently in an M580 X80 drop than Quantum RIO drop, and is compatible with M580 BME•58•40 CPUs.

## Installing a BMXNOM0200.4 Module

To install a BMXNOM0200.4 module in an X80 drop, follow these steps:

Step	Action
1	Install the CPU module on the local rack.
2	Install the adapter module BMXCRA31210 (SV >=2.10) or BMECRA31210 (SV >=2.10) on an X80 drop.
3	Install the BMXNOM0200.4 module in the X80 drop.

## Supported Protocols

For the BMXNOM0200.4 module:

- Channel 0 supports RS-232 or RS-485.
- Channel 1 supports only RS-485.

Declaring the BMXNOM0200 module as a BMXNOM0200.4 module in Control Expert allows you to configure the module for:

- Modbus RTU slave on RS-485

**NOTE:**

- Only Modbus RTU is supported as slave protocol.
- Only RS-485 is supported when Modbus slave is selected.
- Modbus Serial RTU and ASCII Master on RS-232 and RS-485
- Character mode

### Hot Standby

The CPU Main IP address swaps in the case of a PAC switchover. The Modbus requests are still forwarded to the primary CPU.

**NOTE:** The Modbus client application manages the repetition of requests in case of a message loss that could occur during a PAC switchover.

### Maximum Configuration

The maximum configuration of the BMXNOM0200.4 module includes the following elements:

Element	Maximum configuration
Master channel	Four (4) per configured drop with a maximum of 36 expert channels per drop. <b>NOTE:</b> Each configured channel of the BMXNOM0200.4 module counts as an expert channel.
Drop	Six (6) BMXNOM0200.4 per drop. <b>NOTE:</b> With M580 CPU OS version ≤2.40, the maximum number of BMXNOM0200.4 per drop is limited to four (4).
M580 system	Thirty-one (31) BMXNOM0200.4
Modbus frame length	256 bytes

### Supported Modbus Function Codes

This table lists the supported Modbus function codes (FC):

Binding to -> Modbus FC:	Variable type	Code	Function
01	%M	0X	Read coil status (output bit)
02	%M	1X	Read input status (input bit)
03	%MW	4X	Read holding registers



Binding to -> Modbus FC:	Variable type	Code	Function
05	%M	0X	Force single coil
04	%MW	3X	Read input register
06	%MW	4X	Write single register
15	%M	0X	Write multiple coils
16	%MW	4X	Write multiple registers
23	%MW	4X	Read/write multiple registers

## Accessing the Channel Configuration Screens

To access the channel configuration screens of the BMXNOM0200.4 module, follow these steps:

Step	Action
1	In the Control Expert <b>Project Browser</b> , open the BMXNOM0200.4 module.
2	Select the channel to configure. By default: <ul style="list-style-type: none"> <li>• <b>Channel 0</b> is configured with the <b>Character mode link</b> function.</li> <li>• <b>Channel 1</b> is configured with the <b>Modbus link</b> function.</li> </ul> <b>NOTE:</b> Some parameters are not accessible and are grayed out.

**NOTE:** Refer to the *Modicon X80, BMXNOM0200 Serial Link Module, User Manual* for details on these communication protocols.

## Configuring Slave Modbus Link Communication

This table shows the default parameter values for the Modbus slave configuration screen:

Configuration parameter	Default value
Type	Slave
Slave number	1
Physical line	RS-485 only
Signals	RX/TX only
Transmission speed	19200 bits/s
Delay between frames	2 ms

Configuration parameter	Default value
Data	8 bits only
Stop	1 bit
Parity	Even

## Standards and Certifications

### Download

Click the link that corresponds to your preferred language to download standards and certifications (PDF format) that apply to the modules in this product line:

Title	Languages
Modicon M580, M340, and X80 I/O Platforms, Standards and Certifications	<ul style="list-style-type: none"><li>• English: EIO0000002726</li><li>• French: EIO0000002727</li><li>• German: EIO0000002728</li><li>• Italian: EIO0000002730</li><li>• Spanish: EIO0000002729</li><li>• Chinese: EIO0000002731</li></ul>

# Installation

## Overview

This chapter describes the hardware installation of an Modicon X80 remote I/O drop.

## Installing Modicon X80 Modules

### At a Glance

This section describes the installation of an Modicon X80 I/O adapter module.

### Maximum Configuration in RIO Drops

#### Maximum Configuration

The maximum number of I/O modules in an Modicon X80 RIO drop (with both a main remote rack and an extension remote rack) using a BM•CRA312•0 adapter depends on the CPU used in the main local rack.

Refer to your system hardware reference manual to select a CPU that supports the number and types of I/O modules you need.

This table shows the maximum number of modules in an RIO drop with a remote extension rack:

Module Type	Modules in a Drop	Comment
RIO adapter	1	—
power supply	2	—
bus extension	2	A bus extender attaches to the end of each rack and does not use a rack slot.
I/O	—	The number of modules depends on the CPU and the platform used. (Refer to the list of modules that RIO installations support, page 24.)

**NOTE:** Refer to the M580 Hot Standby guide for instructions to configure RIO drops in Hot Standby systems (see Modicon M580 Hot Standby, System Planning Guide for, Frequently Used Architectures).

## Modicon X80 Backplane Considerations

### Introduction

An X80 RIO drop can have one or two racks:

1. main RIO rack: BMEXBP\*\*00 or BMXXBP\*\*0

This rack is required in a drop and contains a BMXCRA31200, BMECRA31210, or BMXCRA31210 EIO adapter module, a power supply, and, optionally, I/O modules.

2. extended RIO rack: only BMXXBP\*\*0

This rack is optional in a drop and contains only I/O modules.

Confirm that extended remote racks are PV 02 or later. Install modules that require Ethernet across the backplane on the main remote rack.

**NOTE:** The BMXCRA31200 does not support an extended RIO rack.

**NOTE:** The mounting screws on the left side of the backplane may be accessible without unplugging the power supply module. Mount the backplane using the far left fastening hole on the panel.

### Compatible Racks

Use these racks in an Modicon X80 RIO drops:

- X BUS (PV 02 or later) backplanes:
  - BMXXBP0400
  - BMXXBP0600
  - BMXXBP0800
  - BMXXBP1200
  - BMXXBP0400H
  - BMXXBP0600H
  - BMXXBP0800H
  - BMXXBP1200H
- Ethernet backplanes:
  - BMEXBP0400
  - BMEXBP0602
  - BMEXBP0800
  - BMEXBP1002<sup>(2)</sup>
  - BMEXBP1200<sup>(1)</sup>
  - BMEXBP0400H

- BMEXBP0602H
- BMEXBP0800H
- BMEXBP1002<sup>(2)</sup>
- BMEXBP1200H<sup>(1)</sup>

- (1) The 12-slot Ethernet rack has eight Ethernet-X Bus slots and four X Bus-only slots.
- (2) The 10-slot Ethernet rack has eight Ethernet-X Bus slots and two X Bus-only slots.

### Rack Selection Considerations

A BMECRA31210 performance EIO adapter module:

- can be installed on an Ethernet rack only.
- can be installed on a PV 02 or later backplane, but it cannot manage Ethernet modules.
- cannot be installed in a PV 01 backplane because of its keying pin, page 22

A BMXCRA31210 or a BMXCRA31200 EIO adapter module:

- can be installed on a PV 02 or later backplane.
- can be installed on an Ethernet backplane, but it cannot manage Ethernet modules. However, it can manage modules that it manages on a PV 02 or later backplane.

### Racks and Extensions

An Modicon X80 RIO drop can include two racks. In a 2-rack drop, the racks are linked with two bus extender modules and a cable:

Bus Extender Module	Cable
BMXXBE1000	BMXXBC•••K (0.8 to 12 m)

### Consideration of a Shielded Cable with an Accessible Metal Part

Follow all local and national safety codes and standards.

DANGER

**HAZARD OF ELECTRIC SHOCK**

If you cannot prove that the end of a shielded cable is connected to the local ground, the cable must be considered as dangerous and personal protective equipment (PPE) must be worn.

**Failure to follow these instructions will result in death or serious injury.**

Do not apply power to an Modicon X80 rack until connections are made at both ends of the Ethernet cable. For example, connect the cable to both the BMECRA31210 performance EIO adapter module and another device (adapter module) or DRS before you turn on the power.

Refer to your system hardware reference manual for details about DRSs.

## Adapter and I/O Module Installation

### Introduction

Observe the following guidelines when you install these adapter modules in an Modicon X80 RIO drop):

- BMECRA31210
- BMXCRA31210
- BMXCRA31200
- 140CRA31908

### Order of Module Installation

Install modules in the selected rack in Control Expert in this order:

1. install the adapter module
2. install a power supply
3. install I/O modules

### Grounding Considerations

#### **DANGER**

##### **ELECTRICAL SHOCK HAZARD**

- Switch off the power supply at both ends of the PAC connection, and lock out and tag out both the power sources.
- In case lock out and tag out are not available, ensure that the power sources cannot be inadvertently switched on.
- Use suitable insulation equipment when inserting or removing all or part of this equipment.

**Failure to follow these instructions will result in death or serious injury.**

**NOTE:** Refer to the ground connection information in [Electrical installation guide](#).

## Consideration of a Shielded Cable with an Accessible Metal Part

Follow all local and national safety codes and standards.

 **DANGER**

**HAZARD OF ELECTRIC SHOCK**

If you cannot prove that the end of a shielded cable is connected to the local ground, the cable must be considered as dangerous and personal protective equipment (PPE) must be worn.

**Failure to follow these instructions will result in death or serious injury.**

## Installation of the Adapter

Control Expert automatically installs an adapter module in slot 0 in an RIO drop.

## Select a Power Supply

Power consumption is 1.2 A on a 5 Vdc power rail on the backplane (6 W). The adapter module supports modules on 1 or 2 racks. (Power consumption has no relation to the number of installed rack modules.)

In Modicon X80 Ethernet RIO drops, insert the power supply only in the double-wide slot to the left of slot 0 marked **CPS**.

Select a power supply that suits your system requirements. These power supplies (and their hardened versions) are supported:

Power Supply Type	Modicon X80 Module
standalone	<ul style="list-style-type: none"> <li>• BMXCPS2010</li> <li>• BMXCPS3020</li> <li>• BMXCPS2000</li> <li>• BMXCPS3500</li> <li>• BMXCPS3540</li> </ul>
redundant	<ul style="list-style-type: none"> <li>• BMXCPS4002</li> </ul> <p><b>NOTE:</b> You can install BMXCPS4002 modules only on these dual-bus racks (Ethernet and X bus):</p> <ul style="list-style-type: none"> <li>• BMEXBP0602</li> <li>• BMEXBP1002</li> </ul>

## Select I/O Modules

Use the Control Expert Hardware Catalog to select the I/O modules needed in your application in the main remote rack and, if available, the extended remote rack.

## Mounting a Module

Use this procedure to install adapters and I/O modules in a rack:

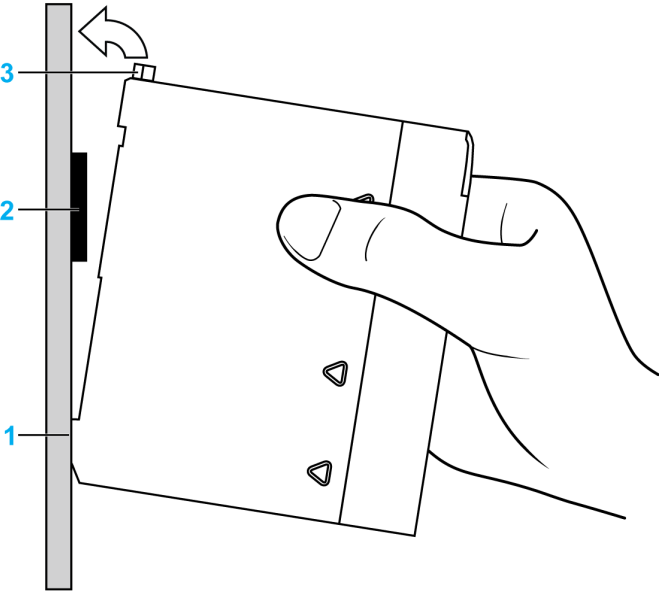
Step	Action
1	<p>Hold the module at an angle and mount it on the 2 hooks near the bottom of the backplane. The figure shows the correct way to hold the module:</p> 
2	Swing the module up so that the connector engages the backplane connector.
3	<p>Tighten the mounting screw so that the module is held in place on the rack.</p> <p>Tightening torque: 0.4...1.5 N•m (0.30...1.10 lbf-ft).</p>

## Replacing a Module

You can replace an Modicon X80 module at any time using another module with compatible firmware. The replacement module obtains its operating parameters over the backplane connection from the CPU. The transfer occurs immediately at the next cycle to the device.



**NOTE:** The operating parameters that the CPU sends to a replacement module do not include any parameter values that were edited in the original module using explicit messaging **SET** commands.

### Installation Results

Applying power to the main local rack after the adapter module is installed can result in either:

- Successful installation:
  - Initialization is finished.
  - Interconnections to other modules are validated (drop adapter module only).
- Unsuccessful installation:
  - Initialization does not finish.
  - Interconnections to other modules are not validated (drop adapter modules only).

You can see the status of the installation on the adapter LED display, page 18.

## Setting the Location of the Ethernet Remote I/O Drop

### Setting Rotary Switches

Set the location of the remote I/O drop on the network with the rotary switches on the front of the adapter module:

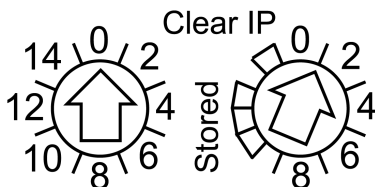

Tens
Device name
Ones

**NOTE:** Set the rotary switches before you apply power to the module and before you download the application.

The values you set are applied during a power cycle. If you change the switch settings after the module has powered up, the Module Status LED, page 18 is activated and a mismatch message is logged in the module diagnostic.

If you want to return to the original setting of a modified rotary switch (and the other switch was changed), turn the switch until the Module Status LED goes from red to green.

New values on the rotary switches are implemented at the next power cycle. Set the value before starting the module (valid values: 00 ... 159).

The values on the rotary switches combine with the device prefix (for example, BMECRA\_xxx or BMXCRA\_xxx) to create the device name (where xxx represents the value of the rotary switches). The preceding figure shows the Tens switch set to 00 and the Ones switch set to 1, for a device name of BMECRA\_001.

**NOTES:**

- The rotary switches can be manipulated with a small flat-tipped screwdriver.
- No software is required to configure or enable the rotary switches.
- Do not use the Stored and Clear IP settings on the Ones rotary switch as they do not apply to remote I/O installations.

## Remote I/O Infrastructure Cables

### Cable Installation

#### Introduction

A copper cable connection between two consecutive RIO drops cannot exceed 100 m. A fiber cable connection between two consecutive RIO drops cannot exceed 15 km (single mode) or 2.5 km (multi-mode).

For more information, refer to chapter *Modicon X80 Racks Installation* (see Modicon X80, Racks and Power Supplies, Hardware Reference Manual) and *Electrical installation guide*.

## Connections Between Devices

This figure shows the distances between RIO drops in a high-capacity daisy chain loop:

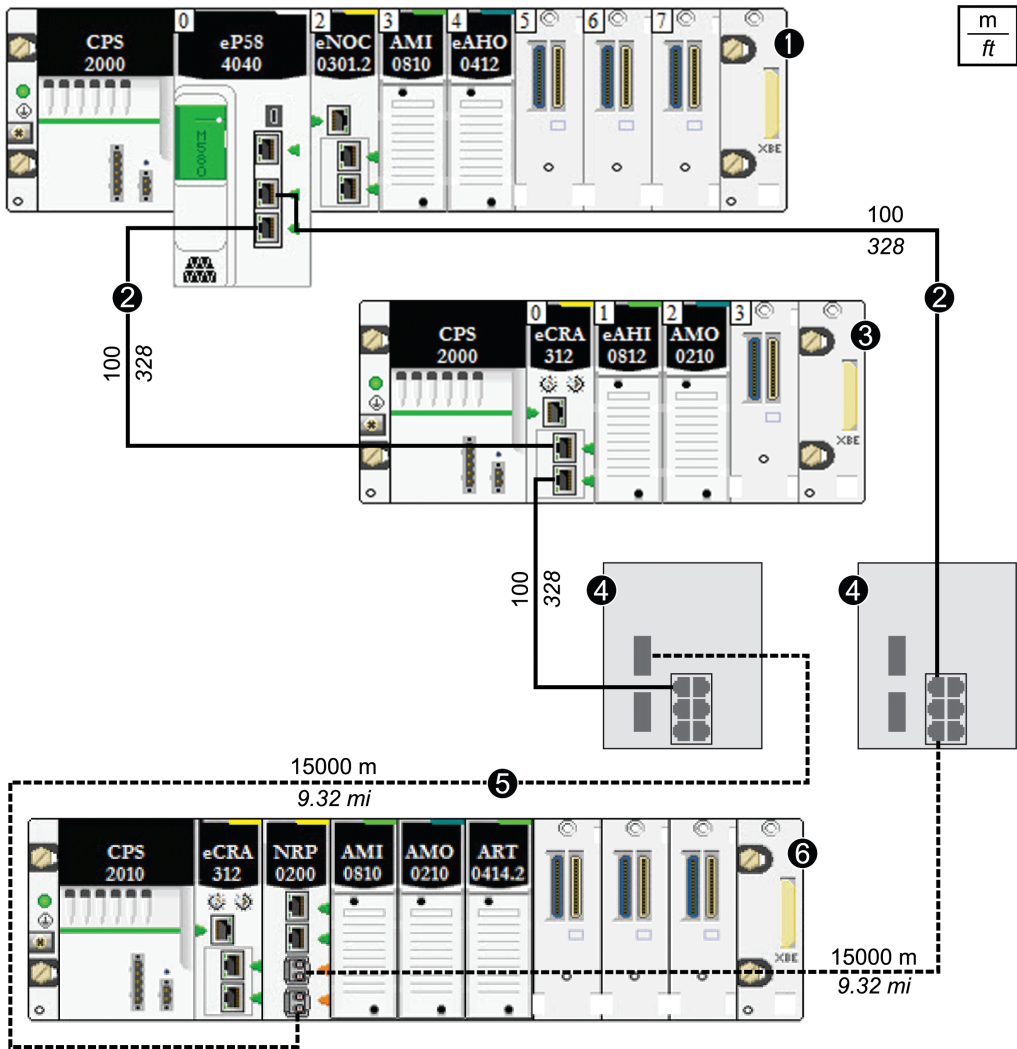

- 1 main local rack
- 2 copper cable (twisted pair)
- 3 RIO drop

**4** DRSs (with copper and optic fiber ports): This DRS extends the distance between devices using fiber optic cable (up to 15 km).

**5** fiber optic cable

**6** RIO drop with a BMXNRP0200 fiber converter module

**NOTE:** It is required to use shielded twisted pair CAT5e (10/100 Mbps) cables, ideally ConneXium 490NTC•000•• cables.

<b>NOTICE</b>
<p><b>COMMUNICATION FAULTS</b></p> <p>Use shielded twisted pair CAT5e (10/100 Mbps) cables to prevent communication faults.</p> <p><b>Failure to follow these instructions can result in equipment damage.</b></p>

## Duplicate IP Address Checking

### Introduction

<b>NOTICE</b>
<p><b>UNINTENTIONAL EQUIPMENT BEHAVIOR</b></p> <p>Confirm that each module has a unique IP address. Duplicate IP addresses can cause unpredictable module/network behavior.</p> <p><b>Failure to follow these instructions can result in equipment damage.</b></p>

Each adapter module has a single IP address for its Ethernet ports. Therefore, the address conflict detection algorithm (duplicate IP checking) is performed based on the status (link up, link down) of the ports.

### Link Down

These conditions apply when links are lost:

Link Status	Description
A transition has occurred from 1 connected link to all links down.	When no module ports are connected to a cable (all links are down), all services are reset. For example, I/O connections, Modbus connections, and explicit EtherNet/IP connections close, but low-level network services (like RSTP or switches) are not affected. The updated Net Status LED indicates the status.
There is 1 link down and at least 1 connected link.	There is no impact on services that are running in the module.

## Link Up

These conditions apply when links are added:

Link Status	Description
A transition has occurred from no connected links to 1 connected link.	A duplicate IP check is performed: <ul style="list-style-type: none"> <li><i>no duplicate</i>: All services start.</li> <li><i>duplicate</i>: I/O services stop. The BM•CRA312•0 adapter module gets new configuration and downloads the IP configuration again. The system goes to default IP and the I/O modules are set to the fallback mode.</li> </ul>
A transition has occurred from at least 1 connected link to an additional connected link.	A duplicate IP check is performed: <ul style="list-style-type: none"> <li><i>no duplicate</i>: All services continue.</li> <li><i>duplicate</i>: All services stop.</li> </ul> <p><b>NOTE:</b> The updated Net Status LED, page 18 indicates the status.</p>

## Loss of I/O Connection

### Conditions

An I/O connection can be lost to a BMECRA31210 or BMXCRA312•0 under these conditions:

- Performing a hot swap by replacing an adapter module with the same type.
- There is no RIO cable connection.
- The I/O connection is closed while the CPU is reconfigured.

### Remote Adapter Fallback

In some instances, the RIO adapter module can lose I/O connections for a period longer than the configured hold up time. During the hold up, the adapter tries to get IP and configuration parameters from the BME•58••40 CPU. If the adapter does not obtain those parameters during the hold up time, the following happens:

- *inputs*: retain last known values
- *outputs*: set to configured fallback value

**NOTE:**

- Configure the hold up time on the Control Expert **Parameter** tab, page 54. For more information, refer to your system planning guide.
- In hot standby systems, this situation occurs only when the adapter module loses the connection to the primary and secondary CPUs.

**NOTE:** Configure the hold up time on the Control Expert **Parameter** tab, page 54. For more information, refer to your system planning guide.

## Adapter Hot Swap

From the system point of view, during an adapter hot swap, when the adapter is removed the I/O values go to fallback values. When the new adapter inserted and switches on and is configured, the I/O values reset to their values before the hot swap.

To reduce the number of transitions after a hot swap, set the configured fallback state the same as the default fallback state (module powered-on but not configured) before performing the hot swap.

# Configuration and Programming with Control Expert

## Introduction

Use Control Expert to configure your remote drops for Ethernet communications.

**NOTE:** The device configuration procedure is valid when configuring a project with Control Expert Classic. When you configure your device from a system project, some commands are disabled in the Control Expert editor. In this case, you need to configure these parameters at the system level by using the Topology Manager.

## Creating a Control Expert Project

### At a Glance

Use the instructions in this section to create a Control Expert project that allows communication between the I/O scanner and RIO modules.

## Configuring the RIO Drop

### Introduction

Use these instructions to create a Control Expert project that allows communication between the I/O scanner and RIO modules.

### Stages

Here are the basic stages of the Control Expert configuration:

Stage	Description
1	Select a CPU and a power supply to create a new Control Expert configuration. (Refer to the <i>Modicon M580 Hardware Reference Manual</i> (see Modicon M580, Hardware, Reference Manual)).
2	Configure a rack assembly for the RIO drop (in this section).

To help secure a Control Expert project against unwanted modifications, refer to the *Modicon M580 Hardware Reference Manual* (see Modicon M580, Hardware, Reference Manual).

**NOTE:** These instructions assume that you have a working knowledge of Control Expert.

## Rack Considerations

RIO rack considerations:

- The number of the first slot in a X80 rack is 0. Therefore, a 4-slot rack includes slot numbers 0, 1, 2, 3.
- You can cut or copy other devices in the remote drop and paste them in any rack of the same type, but you cannot move objects from a local rack to the drop or from a drop to the local rack. Also, you can only perform these actions (cut, copy, paste) in the same device editor.

## Configuring a Remote Main RIO Drops

When a BME•58••40 CPU module in the main local rack Control Expert automatically creates a second bus, the **EIO Bus**.

Use these instructions to configure a main RIO drop (on a **EIO Bus**):

Step	Action	Comment
1	In the <b>Project Browser</b> , double-click <b>EIO Bus</b> to see the (empty) RIO local rack.	<b>Tools &gt; Project Browser &gt; Structural view &gt; Project &gt; Configuration &gt; EIO Bus</b>
2	In the <b>EIO Bus</b> window, double-click the square link connector to access the available racks.	The <b>New Device</b> dialog appears.
3	Select a rack.	This example uses the 4-slot BMEXBP0400 rack: <b>New Device &gt; Part Number &gt; Modicon M580 remote drop &gt; Rack &gt; BME EEP 0400</b> .
4	In the <i>Drop end communicator</i> area, select a CRA adapter.	This example uses the default BMECRA31210 adapter.
5	Click <b>OK</b> .	The rack with the CRA adapter opens.
6	Click the rack to the left of the CRA adapter to add a power supply.	This example uses a <i>BMX CPS 2000</i> .
7	Double-click empty slots to add <b>Modicon M580 remote drop</b> modules to the <b>EIO Bus</b> .	For this example, none are added.
8	Save the file.	Click <b>File &gt; Save</b> .

To add:

- another RIO drop, click the rounded square at the bottom of the dialog
- a remote drop extension rack, click the >> on the right side of the remote drop main rack



**NOTE:** When physically installing a remote drop extension rack, add Bus Extender modules and cables, page 37.

### Maximum Channel Configuration

The maximum number of channels that can be configured for an X80 RIO drop is either:

- 1024 digital channels
- 1024 channels that include 256 analog channels

The number maximum of input channels that can be configured for analog modules is 236. In such a configuration, no other modules can be configured in the RIO drop.

**NOTE:** If a serial Modbus network is added to an RIO drop, take in to account the number of channels declared when calculating the number maximum of channel supported by the RIO drop.

### Control Expert Configuration Tabs

After you have placed your modules in the remote drop, double-click the RIO drop adapter module to see the available Control Expert configuration tabs:

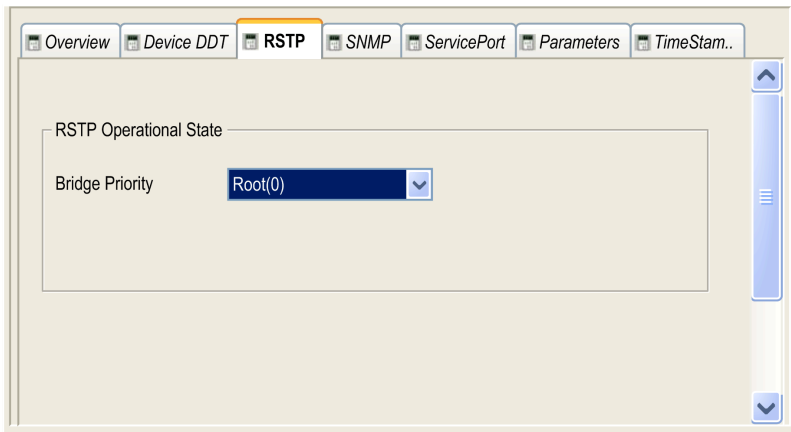

- Device DDT, page 58
  - RSTP, page 50
  - SNMP, page 51
  - Service port, page 52
- The service port is not available on a drop with a BMXCRA31200 adapter.
- Parameters, page 54

- Time Stamping, page 56

## Control Expert Configuration for Ethernet RIO Modules

### At a Glance

This section describes the module configuration tabs in Control Expert. Use the parameters on these tabs to configure services for a BM-CRA312\*0 adapter module in an Ethernet RIO drop.

### RSTP Bridge Configuration

#### About RSTP

The RSTP service supports the inherent network communications redundancy provided by a daisy chain loop. The RIO communications automatically find an alternate path if a communication disruption occurs (for example, a cable breaks or a device becomes inoperable). This service does not require you to manually enable or disable the communication paths.

Changing RSTP parameters can affect subring diagnostics, I/O determinism, and network recovery times.

#### Access the RSTP Tab

Double-click the adapter module in the Control Expert configuration to access the **RSTP** tab.

#### Parameters

This table shows the **Bridge priority** parameters for the **RSTP Operational State** on the Control Expert **RSTP** tab:

Bridge Priority	Value	BME*58**40 CPU	Adapter Module
Root	0	default	—
Backup root	4096	Reserved	—
Participant	32768	—	default

**NOTE:** Use the default value for the adapter modules.

## SNMP Agent Configuration

### About SNMP

An SNMP V1 agent is a software component of the SNMP service that runs on an adapter modules and gives you access to diagnostic and management information for the modules. You can use SNMP browsers, network management software, and other tools to access this data.

In addition, the SNMP agent can be configured with the IP addresses of 1 or 2 devices (typically PCs that run network management software) to be the targets of event-driven trap messages. Such messages inform the management device of events like cold starts and the inability of the software to authenticate a device.

### Access the SNMP Tab

Double-click the adapter module in the Control Expert configuration to access the **SNMP** tab.

The SNMP agent can connect to and communicate with 1 or 2 SNMP managers. The SNMP service includes:

- authentication checking by the Ethernet adapter module of any SNMP manager that sends SNMP requests
- management of events or traps

### SNMP Parameters

These parameters are found on the Control Expert **SNMP** tab:

Field	Parameter	Description	Value
IP Address managers	IP Address manager 1	The address of the first SNMP manager to which the SNMP agent sends notices of traps.	0.0.0.0 ... 255.255.255.255, page 52
	IP Address manager 2	The address of the second SNMP manager to which the SNMP agent sends messages of traps.	
Agent	Location (SysLocation)	device location	31 characters (maximum)
	Contact (SysContact)	information about the person to contact for device maintenance	
	Enable SNMP manager	<i>unchecked</i> (default): You can edit the <b>Location</b> and <b>Contact</b> parameters.	checked/unchecked

Field	Parameter	Description	Value
		<i>checked</i> : You cannot edit the <b>Location</b> and <b>Contact</b> parameters.	
Community names	Set	password that the SNMP agent requires to read commands from an SNMP manager (default = <b>Public</b> )	15 characters (maximum)
	Get		
	Trap		
Security	Enable "Authentication failure" trap	<i>unchecked</i> (default): not enabled. <i>checked</i> (enabled): The SNMP agent sends a trap message to the SNMP manager if an unauthorized manager sends a <b>Get</b> or <b>Set</b> command to the agent.	checked/unchecked

## Offline IP Address Verification

Offline tests are done to verify that the IP addresses of the managers do not include the following types of IP addresses:

- multicast: 224.0.0.0 or higher
- loopback: Any address that starts with 127
- broadcast: 255.255.255.255

## Service Port Configuration

### Access the Service Port Tab

The BM•CRA31210 adapter modules have a service port that can be configured for Ethernet communications or for port mirroring.

Double-click the adapter module in the Control Expert configuration to access the **Service Port** tab.

### Service Port Parameters

These parameters are on the Control Expert **Service Port** tab:

Field	Parameter	Value	Comment
Service Port	Enabled	—	Enable port and edit port parameters.
	Disabled	—	Disable port parameters.

Field	Parameter	Value	Comment
<b>Service Port Mode</b>	<b>Access</b> (default)	—	This mode supports Ethernet communications.
	<b>Mirroring</b>	—	In port mirroring mode, data traffic from one or more of the other ports is copied to this port. A connected tool can monitor and analyze port traffic.  <b>NOTE:</b> In this mode, the service port acts like a read-only port. That is, you cannot access devices (ping, connection to Control Expert, etc.) through the service port.  <b>NOTE:</b> This mode is not available on the BMXCRA31200.
<b>Access Port Configuration</b>	<b>Service Port Number</b>	ETH1	You cannot edit the value in the <b>Service Port Number</b> field.
<b>Port Mirroring Configuration</b>	<b>Source Port (s)</b>	<b>Internal Port</b>	Ethernet traffic through the internal port
		<b>ETH2</b>	Ethernet traffic through the first RIO port
		<b>ETH3</b>	Ethernet traffic through the second RIO port
		<b>Backplane Port</b>	Ethernet traffic through the backplane port

## Online Behavior

The **Service Port** parameters are stored in the application, however you can reconfigure (change) the parameters in the connected mode. Values that you reconfigure in the connected mode are sent to the remote drop adapter module or the CPU module in explicit messages. If the module does not respond to the explicit messages, a message appears.

**NOTE:** The changed values are not stored, so a mismatch can exist between the parameters that are being used and those that are in the stored application.

**NOTE:** The **Service Port** configuration can be read and modified online using the Service Port Control Object, page 97 CIP object.

## Control Expert Configuration for RIO Drops

### At a Glance

This section discusses the use of Control Expert to configure the Ethernet RIO drop and its adapter module. Included are descriptions of the parameters on the **Configuration**, **Parameter**, and **Device DDT** tabs in Control Expert.

## Configuring Remote Drop Parameters

### Introduction

In the Control Expert **Parameters** dialog, you can:

- define or verify address information about the adapter module (name, IP address, and subnetwork mask)
- specify a hold-up time interval
- specify I/O refresh rates

### Access the Parameter Dialog

To access the **Parameters** dialog in Control Expert:

Step	Action	Comment
1	Expand (+) <b>EIO Bus</b> in the Control Expert <b>Project Browser</b> .	<b>Project Browser &gt; Configuration &gt; EIO Bus &gt; Modicon M580 remote drop &gt; Installed BMX/ BME rack</b>
2	Double-click the installed adapter.	The <b>X80 performance EIO adapter</b> window appears.
3	Select the <b>Parameter</b> tab.	The <b>Parameter</b> dialog appears.

### Parameter Descriptions

**Address information** parameters:

Parameter	Comment
<b>Device Name</b>	<p>The name of the adapter module includes a fixed prefix and a number provided by the rotary switch. Valid names conform to this structure: BM•CRA_XXX, where XXX equals the 3-digit value selected on the rotary switch.</p> <p>When the adapter is placed in the remote drop, the number is set to the device number. The device number does not change if the device moves to a new location.</p> <p>Each adapter needs to be assigned a unique number within the application. A message like this appears when analysis reveals a duplicate number:</p> <pre>{EIO Bus (2) BME CRA 312 00}: Device name is not unique</pre>
<b>IP Address</b>	<p>You cannot edit the <i>IP address</i> and <i>sub network (mask)</i> fields.</p> <p><b>NOTE:</b> The IP address is editable only in the <b>IP Configuration</b> tab of the CPU module. The value for <i>sub network</i> is deduced from the CPU sub-network mask.</p>
<b>Sub Network</b>	

Edit the **Device Name** in Control Expert:

Step	Action
1	In the X80 performance EIO adapter window, select the <b>Parameter</b> tab.
2	Click the <b>Update IP/DHCP</b> configuration hyperlink. <b>NOTE:</b> An <b>Ethernet Network</b> table that lists all RIO drops in the system appears.
3	Double-click the arrow in the <b>Identifier</b> column matching the desired RIO drop in the BME•58_ECPU_EXT column.
4	Edit the <b>Device Name</b> in the <b>Identifier</b> field to reflect the new name
5	Close the <b>Ethernet Network</b> window and validate your project.

**Hold up time parameter:**

Parameter	Comment
<b>Hold up time</b>	The hold up time represents the time (ms) that device outputs are maintained in their current states after a communication disruption and before taking their fallback values: <ul style="list-style-type: none"> <li>• <b>default value:</b> 1000 ms</li> <li>• <b>valid value range:</b> 50...65,530 ms</li> </ul>

If you assign a hold up time value that is less than the recommended minimum value, an I/O module may move to its fallback state. When communications are restored, the I/O module restarts and may not operate as anticipated.

There is only one hold up time for an RIO drop (not one for each task) based on the watchdog value.

One RPI per task = task period/2

⚠ WARNING
UNINTENDED EQUIPMENT OPERATION
Do not configure a holdup time value that is less than the recommended minimum values, which are:
<ul style="list-style-type: none"> <li>• for a periodic application: 6 x PAC scan time</li> <li>• for a cyclic application: configured watchdog value</li> </ul>
<b>Failure to follow these instructions can result in death, serious injury, or equipment damage.</b>

**Connection parameter:**

Parameter	Comment
Custom RPI	Select this to configure the <b>CRA-&gt;Scanner RPI</b> setting.
<b>CRA-&gt;Scanner RPI</b>	<p><b>Inputs:</b> The RPI is the input refresh rate at which the adapter module sends inputs to the CPU with Ethernet I/O scanner service. The RPI is set in the subscribe field for the adapter on the remote I/O drop:</p> <ul style="list-style-type: none"> <li><i>periodic mode:</i> default value = 1/2 MAST period.</li> <li><i>cyclic mode:</i> default value = 1/4 watchdog timeout period.</li> </ul>
<b>Scanner-&gt;CRA RPI</b>	<p><b>Outputs:</b> Outputs are passed from the CPU with Ethernet I/O scanner service to the adapter. The default values are:</p> <ul style="list-style-type: none"> <li><i>periodic mode:</i> default value = 1.1 * MAST period.</li> <li><i>cyclic mode:</i> default value = 1/4 * watchdog timeout period.</li> </ul> <p>You cannot edit this value. The outputs are published synchronously or immediately at the end of the current MAST task.</p> <p><b>NOTE:</b> The default value for the watchdog timer is 250 ms. If the MAST task does not finish within the watchdog period, the process times out.</p>

**NOTE:**

- When the **Periodic** mode is selected for the MAST task, the **Period** value allows the complete execution of the logic. (The MAST can overrun when its execution time exceeds this value.) Valid values: 1...255 ms (increment: 1 ms).
- When **Cyclic** mode is selected for the MAST task, the outputs are sent upon the completion of the task. The **Watch Dog** value (10 ... 1500 ms, increment: 10 ms, default = 250 ms) should be greater than the execution time.

## LL984 Function Blocks

Quantum RIO drops that are used in a Modicon M580 system can use LL984 function blocks. For details, refer to Unity Pro Enhanced LL984 Block Library (see EcoStruxure™ Control Expert, UnityLL984, Block Library).

## Time Stamping

### RIO Drop Adapter Time Stamping Function

The BMXCRA31210 and BMXCRA31210 adapter modules have a 10 ms time stamping function. The BMXCRA31200 does not support time stamping.

Time stamping of the I/O modules starts as soon as the adapter is configured.



To configure the time stamping buffer, double-click the adapter module and click the **TimeStamping** tab:

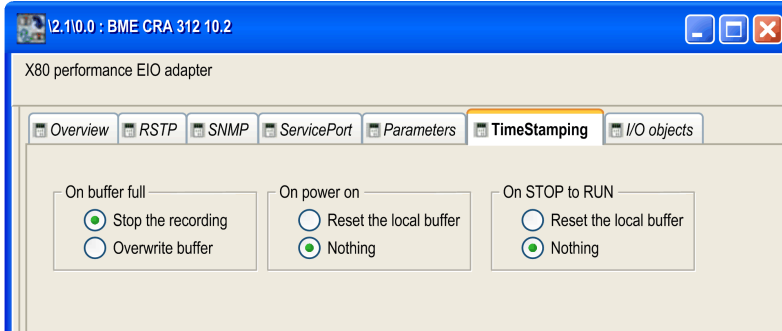

The **local buffer** refers to the buffer in the adapter module.

To configure the BM•CRA31210, refer to BMX CRA 1604 T Variables Settings in Unity Pro (see System Time Stamping, User Guide).

When using one or two As-i Bus BMX EIA 0200 modules with other modules in a Modicon X80 RIO drop, the accuracy of the timestamps may be reduced.

Some examples:

Discrete I/O 32 Channels	Analog I/O 4 Channels	BMXEIA0100	BMXNOM0200	Stamping Accuracy	
				Dedicated High Accuracy NTP Server	Internal NTP Server Stamping Accuracy
6 modules	1 module	0	0	10 ms	10 ms
6 modules	1 module	1 module	1 module	12 ms	22 ms
16 modules	4 modules	1 module	1 module	14 ms	24 ms

### 1 ms Time Stamping with BMXERT1604T

Use a BMXERT1604T time stamp module for more accurate (1 ms) time stamping.

To configure the BMXERT1604T, refer to this manual (see Modicon X80, BMXERT1604T/H Time Stamp Module, User Manual).

### For More Information about Remote Time Stamping

For more information about time stamping in a Modicon X80 RIO drop, refer to:

- *System Time Stamping User Guide*

- *Applicative Time Stamping with Unity Pro User Guide*

## Device DDT Names for M580 RIO Adapters

### Introduction

The Device DDT instance name can be defined manually but, when adding a module, a default device DDT instance name (see EcoStruxure™ Control Expert, Program Languages and Structure, Reference Manual) is defined by Control Expert.

**NOTE:** These instructions assume that you have already added a drop to your Control Expert project, page 35.

### Access the Device DDT Tab

In Control Expert:

Step	Action	Comment
1	Expand <b>EIO Bus</b> in the Control Expert <b>Project Browser</b> to display the <b>Modicon M580 remote drop</b>	<b>Project Browser &gt; Project &gt; Configuration &gt; EIO Bus &gt; Modicon M580 remote drop</b>
2	Double-click the installed drop adapter in the Modicon X80 Remote drop.	The <b>X80 performance EIO adapter</b> dialog appears.
3	Select the <b>Device DDT</b> tab.	

The **Implicit device DDT** field contains a name and a type.

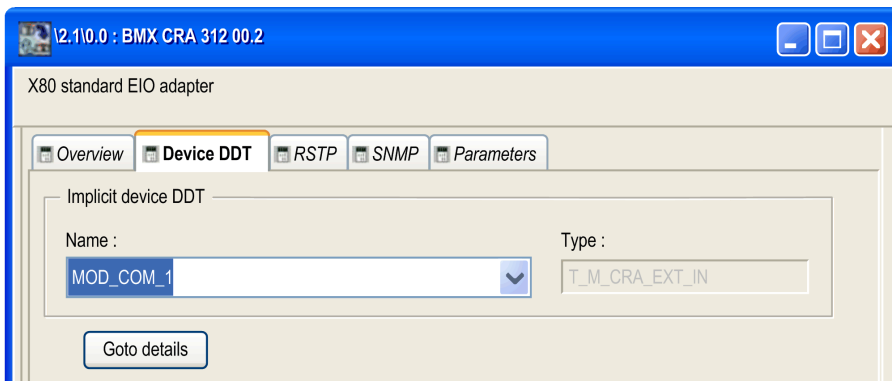

## Drop Parameters

In the Control Expert **Device DDT** dialog, you can configure these parameters for the RIO drop:

Parameter		Description
Implicit device DDT	Name	A default device DDT instance name (see EcoStruxure™ Control Expert, Program Languages and Structure, Reference Manual) is defined by Control Expert.
	Type	module type (read only)
Goto details		Click this link to the <b>Device DDT Data Editor</b> screen.

## Diagnostic Parameters

Click the **Goto details** button on the **Device DDT** screen to view the **Variables** tab in the **Data Editor**. The bits indicates healthy (1) or unhealthy/unconfigured (0).

View the drop diagnostic parameters in T\_M\_CRA\_EXT\_IN for an RIO drop module:

Name	Type	Bit	Description	
IO_HEALTH_RACK0	WORD	—	health bits of rack 0: slots 0...15 <b>NOTE:</b> Slot 0 is on the Least Significant bit of the Word.	
IO_HEALTH_RACK1	WORD	—	health bits of rack 1: slots 0...15 <b>NOTE:</b> Slot 0 is on the Least Significant bit of the Word.	
DEVICE_NAME	string[16]	—	device name of the RIO drop	
VERSION	WORD	—	firmware version (Maj, Min) (4 digits coded in BCD)	
ROTARY_SWITCHES	BYTE	—	rotary switch value at power up	
CRA_STATE	BYTE	—	1: CRA module is idle.	
			2: CRA module is stopped.	
			3: CRA module is running.	
CRA_DIAGNOSTIC [WORD]	GLOBAL_IO_HEALTH	BOOL	0	0: At least one I/O module in the drop reports bad health.
	CCOTF_IN_PROGRESS	BOOL	1	CCOTF is in progress on the drop managed by the CRA.
	CCOTF_INVALID_CONF	BOOL	2	CCOTF is not valid on the drop managed by the CRA.

Name		Type	Bit	Description
	IOPL_MISMATCH	BOOL	3	The I/O configuration in the drop differs from that expected by the CPU for the current application.
	SWITCH_CHANGE	BOOL	4	The rotary switch settings have changed since the last power up.  This bit is reset if the rotary switch is returned to its original setting.
	DROP_COM_HEALTH	BOOL	5	This bit shows the drop communication health (set to 1 when communication is established between the RIO drop and the I/O scanner).
	REDUNDANT_POWER_SUPPLY_STATUS	BOOL	6	This bit shows that redundant power is present (1) or not present (0).
CYCLE_CURR_TIME		UINT	—	This word indicates the execution time of the last CRA cycle.  It has values between [0.65535] with a resolution of 0.01 ms, therefore, the last cycle time is between [0.655] ms.
CYCLE_MAX_TIME		UINT	—	This word indicates the longest CRA cycle execution time since the last start.  It has values between [0.65535] with a resolution of 0.01 ms, therefore, the longest cycle time is between [0.655] ms.
CYCLE_MIN_TIME		UINT	—	This word indicates the shortest CRA cycle execution time since the last start.  It has values between [0.65535] with a resolution of 0.01 ms, therefore, the shortest cycle time is between [0.655] ms.
TIME_STAMP_RECORDS		UINT	—	This word contains the number of records available in the local drop event buffer.
TS_DIAGNOSTIC_FLAGS (WORD)	TIME_VALID	BOOL	0	The time is valid and synchronized.
	CLOCK_FAILURE CLOCK_NOT_SYNC	BOOL	1 2	If <ul style="list-style-type: none"> <li>bit 1 = 1 &amp; bit 2 = 1, since power-on CRA adapter has not received a response from NTP server.</li> <li>bit 1 = 0 &amp; bit 2 = 1, CRA adapter has received a response from NTP server in the past but is not currently receiving the time from the NTP server</li> </ul>

Name		Type	Bit	Description
				<ul style="list-style-type: none"> <li>bit 1 = 0 &amp; bit 2 = 0, Time is valid, CRA adapter is receiving responses from the NTP server.</li> </ul>
	BUFF_FULL	BOOL	3	The local drop event buffer is full.
TS_BUF_FILLED_PCTAGE		BYTE	—	This byte reports the percentage of the local drop event buffer filled (0...100).
TS_EVENTS_STATE		BYTE	—	Refer to Main States, page 63.
ETH_STATUS (BYTE)	PORT1_LINK	BOOL	0	0 = Port 1 (ETH1) link is down.
				1 = Port 1 (ETH1) link is up.
	PORT2_LINK	BOOL	1	0 = Port 2 link is down.
				1 = Port 2 link is up.
	PORT3_LINK	BOOL	2	0 = Port 3 link is down.
				1 = Port 3 link is up.
	ETH_BKP_PORT_LINK	BOOL	3	0 = Ethernet backplane link is down.
				1 = Ethernet backplane link is up.
RPI_CHANGE	BOOL	4	RPI change: EtherNet/IP RPI change is in progress (during CCOTF).	
REDUNDANCY_OWNER	BOOL	6	1 = Redundant owner is present.	
			0 = Redundant owner is not present.	
GLOBAL_STATUS <b>NOTE:</b> Refer to the <b>SERVICE_STATUS</b> byte below.	BOOL	7	0 = At least 1 service is not operating normally.	
			1 = All services are operating normally.	
SERVICE_STATUS (BYTE)	RSTP_SERVICE	BOOL	0	0 = RSTP service is not operating normally.
				1 = RSTP service is operating normally or disabled.
	SNTP_SERVICE (reserved)	BOOL	1	0 = SNTP service is not operating normally.
				1 = SNTP service is operating normally or disabled.
	PORT502_SERVICE	BOOL	2	0 = Port 502 service is not operating normally.
				1 = Port 502 service is operating normally or disabled.

Name		Type	Bit	Description
	SNMP_SERVICE	BOOL	3	0 = SNMP service is not operating normally.
				1 = SNMP service is operating normally or disabled.
	ETH_BKP_FAILURE	BOOL	5	0 = Ethernet backplane hardware status is not OK.
				1 = Ethernet backplane hardware status is OK.
	ETH_BKP_ERROR	BOOL	6	0 = An error is detected on the Ethernet backplane.
				1 = No errors are detected on the Ethernet backplane.
ETH_PORT_STATUS (BYTE)	These combined 2-bit values indicate the port conditions.	WORD	1/0	Ethernet backplane port 1 function
			3/2	Ethernet port 1 RSTP role
			5/4	Ethernet backplane port 2 function
			7/6	Ethernet port 2 RSTP role
			9/8	Ethernet backplane port 3 function
			11/10	Ethernet port 3 RSTP role
			12/13	Ethernet backplane port 4 function
			14/15	Ethernet port 4 RSTP role
	port function	—	0	disabled
			1	access port
			2	port mirror
			3	RIO network port
	RSTP role	—	0	alternate
			1	backup
			2	designated
3			root	
NTP_UPDATE		UINT	—	elapsed time (100 ms) since last update from NTP server
MAX_PACKET_INTERVAL		UINT	—	maximum packet interval (ms) for output packets (from scanner to adapter)

Name	Type	Bit	Description
IN_BYTES	UINT	—	number of bytes (octets) received on interface
IN_ERRORS	UINT	—	number of inbound packets that contain detected errors
OUT_BYTES	UINT	—	number of bytes (octets) sent on interface
OUT_ERRORS	UINT	—	number of outbound packets that contain detected errors
SOE_UNCERTAIN	BOOL	—	The sequence of events SOE in the local drop event buffer is not known. The SOE_UNCERTAIN is reset when the sequence of events is OK.

### Main States of the Time Stamp Source

The TS\_EVENTS\_STATE byte reports the main state of the source of the time stamp events:

Byte Value (hex)	Description
20	wait for client
31	ValuesSynchro requested and waiting for buffer below the threshold
32	ValuesSynchro started
40	event Stamping

### Device DDT Types for I/O Modules

Refer to the following user guides for specific I/O module device DDT types:

I/O Module	User Guide Reference
Modicon X80 discrete input/output	<i>Modicon M340 Using Unity Pro Discrete Input/Output Modules User Manual</i>
Modicon X80 analog input/output	<i>Modicon M340 with Unity Pro Analog Input/Output Modules User Manual</i>
BMXEHC0800	<i>Modicon M340 with Unity Pro Counting Module BMXEHC0800 User Manual</i>
BMXEHC0200	<i>Modicon M340 with Unity Pro Counting Module BMXEHC0200 User Manual</i>
BMXNOM0200	<i>Modicon M340 with Unity Pro Serial Link User Manual</i>
BMXERT1604T	<i>BMXERT1604T M340 ERT Module User Manual</i>

# Implicit and Explicit Messaging

## Explicit Messaging

### Use of Explicit Messaging

The CPU uses explicit messaging for request-and-reply communications for non-real-time information (like configuration and diagnostic data).

EtherNet/IP uses the TCP/IP and UDP/IP protocols to implement explicit messaging over the high capacity daisy chain ring used in a Modicon M580 system.

## Implicit I/O Exchanges

### Task Management

This topic explains implicit I/O and the relationship between the task configuration and the RIO implicit exchanges.

Implicit messaging maintains open connections for real-time communications of a predefined nature between consumers and producers. Implicit I/O exchanges contain control data and a connection identifier.

EtherNet/IP uses the TCP/IP and UDP/IP protocols to implement implicit messaging.

### M580 Implicit Messaging Communication Parameters

M580 implicit messaging communication parameters are automatically configured when you add a module to a project. To complete the configuration of implicit I/O exchanges to RIO modules, you need to assign a task to each I/O module. The availability of tasks that you can assign to a module – MAST, FAST, AUX0 or AUX1 – depends on:

- the location of the module (see EcoStruxure™ Control Expert, Program Languages and Structure, Reference Manual) (i.e. if it is placed on a local rack, is part of an RIO drop, or is a distributed device), and
- the tasks supported by the adapter module used in an RIO drop, page 14.

### Access the MAST Configuration

To view the **Properties of MAST**:



Step	Action
1	Go to the <b>Properties of MAST</b> dialog box in Control Expert ( <b>Tools &gt; Project Browser &gt; Project &gt; Program &gt; Tasks &gt; MAST</b> ).
2	Right-click <b>MAST &gt; Properties</b> to open the <b>Properties of MAST</b> dialog.
3	Configure the parameters as needed.

## Access the FAST Configuration

To view the **Properties of FAST**:

Step	Action
1	Go to the <b>Properties of FAST</b> dialog box in Control Expert ( <b>Tools &gt; Project Browser &gt; Project &gt; Program &gt; Tasks &gt; FAST</b> ).
2	Right-click <b>FAST &gt; Properties</b> to open the <b>Properties of FAST</b> dialog.
3	Configure the parameters as needed.

## Access the AUX0 Configuration

To view the **Properties of AUX0**:

Step	Action
1	Go to the <b>Properties of AUX0</b> dialog box in Control Expert ( <b>Tools &gt; Project Browser &gt; Project &gt; Program &gt; Tasks &gt; AUX0</b> ).
2	Right-click <b>AUX0 &gt; Properties</b> to open the <b>Properties of AUX0</b> dialog.
3	Configure the parameters as needed.

## Access the AUX1 Configuration

To view the **Properties of AUX1**:

Step	Action
1	Go to the <b>Properties of AUX1</b> dialog box in Control Expert ( <b>Tools &gt; Project Browser &gt; Project &gt; Program &gt; Tasks &gt; AUX1</b> ).
2	Right-click <b>AUX1 &gt; Properties</b> to open the <b>Properties of AUX1</b> dialog.
3	Configure the parameters as needed.

## Periodic and Cyclic Modes

The effect that periodic and cyclic modes have on implicit I/O is explained in the description of the connection parameters, page 54.

## I/O Management for Implicit I/O Exchanges

There are no state RAM addresses for (e)X80 I/O modules in RIO drops in an M580 system.

**NOTE:** State RAM is supported in Unity Pro v11.0 (and later) in M580 applications that contain Quantum RIO drops.

# Diagnostics

## Overview

This chapter describes the diagnostics for the Modicon M580 modules. For details on diagnostics at the system level, refer to the systems diagnostics topic in your system planning guide.

## Service Port Management

### Service Port Configuration

#### Introduction

A BME•58••40 RIO scanner module and an RIO adapter modules (BM•CRA31210) support the configuration of the SERVICE port without requiring you to rebuild or download your application.

#### Adapter Modules

You can send explicit messages with an EtherNet/IP tool for the configuration of the SERVICE port on the BM•CRA31210 modules. For details, refer to information about EtherNet/IP CIP objects in your system hardware reference manual and SERVICE port configuration for adapter modules, page 52.

#### Cycling Power

The online configuration of the SERVICE port is volatile. The following may result when power is cycled to the adapter module while the application is being applied:

- The configuration can be lost.
- The configuration in the application can be applied to the SERVICE port.

# Diagnostics Available through the CPU

## System Diagnostics

### Introduction

System diagnostics are performed by using:

- system bits (%S) and system words (%SW)
- Modbus/TCP, page 70 or EtherNet/IP CIP, page 71 requests
- diagnostic parameters in the T\_CRA\_EXT\_IN, page 59 DDT.

### RIO Drop Diagnostics

Certain Ethernet RIO drop diagnostics are accessible for the entire drop within system bits and words in the PAC (%S, %SW). Each drop is animated with a health bit display of the health bit status for:

- a drop node
- a module in a remote drop

The CPU I/O scanner monitors RIO drops and module health. The adapter modules in the RIO drops transmit detected errors in the drop modules to the CPU via implicit messages, page 64. The detected errors are stored in the global diagnostic buffers of the CPU and in the diagnostic buffer of the individual drop modules.

The CPU updates the detected error buffers. Health bits are updated in the CPU only if the adapter of the concerned drop communicates with the CPU. If these modules cannot communicate, the concerned health bits are set to 0.

### System Bits and Words

This table describes the system bits and words for M580 that represent detected errors:

System Bits/Words	Symbol	Description
%S117	EIOERR	detected RIO error
%SW101	EIO_CCOTF_COUNT	CCOTF counting status register
%SW108	FORCED_DISCRETE_COUNT	forced bit counting status register
%SW109	FORCED_ANALOG_COUNT	forced bit counting status register

**NOTE:** Refer to the *Unity Pro Program Languages and Structure Reference Manual* complete explanations of the system bits and words.

## Ethernet Diagnostics Using MB/TCP Requests

Ethernet Diagnostics from the BM•CRA312•0 adapter:

- Data rate on the Ethernet TCP/IP network<sup>(1)(2)</sup>: This is the link speed in Mbps.
- Ethernet Activity information<sup>(1)(2)</sup>: This is the counter of Ethernet frames transmitted and received by the BM•CRA312•0 adapter.
- Ethernet link status<sup>(1)</sup>: For each Ethernet port, is its link up (1) or down (2). See also Duplicate IP Address Checking, page 44.
- redundancy\_owner: This provides information about the presence of a redundant owner in *Hot Standby* systems.
- redundant\_power\_supply\_status: This provides information about the redundancy of the power supply.
- Port 502 Status<sup>(1)</sup>: Modbus port
- Half / Full duplex mode<sup>(1)(2)</sup>: This is the mode of the RIO network.
- Ethernet backplane configuration error<sup>(1)</sup>: This is set 1 if either:
  - there is a detected error in the Ethernet backplane configuration
  - the Ethernet backplane firmware version is lower than the one required by the application

Legend:

**(1)** Accessible through explicit Modbus/TCP, page 70 requests

**(2)** Accessible through explicit EtherNet/IP CIP, page 71 requests

## Viewing Diagnostics in Control Expert

The bus editor in Control Expert uses color animation to display the status of each drop, rack, or module on the **EIO Bus**.

The slot number of the drop/rack/module appears in red when a detected error is associated with that slot.

For a module, the red display indicates the module is missing, inoperable, or improperly configured.

This table relates a drop, rack, or module to its language object:

Drop	Status	Language Object	i	j
	drop (d)	%SWi.j	$152 + [(d-1)/31]$	$(d-1)/31$
BM• CRA 312 •0	rack (r), drop (d)	%SWi	$641 + [(d-1)*2] + r$	
	module (m), rack (r), drop (d)	%SWi.j	$641 + [(d-1)*2] + r$	30-m

**NOTE:** Remember:

- The slots in a drop are numbered 0...n.
- The rack numbers are used in remote drops:
  - 0: main rack in the RIO drop
  - 1: extended rack in the RIO drop

## Diagnostics Available through Modbus/TCP

### Modbus Diagnostic Codes

#### Supported Diagnostic Codes

The following Modicon M580 modules support these Modbus diagnostic codes:

- CPU with Ethernet I/O scanner service
- RIO adapter modules:
  - BMECRA31210
  - BMXCRA31210
  - BMXCRA31200

### Diagnostic

**Function code 8, subcode 22:** Modbus function code 08 provides a variety of diagnostic functions:

Operation Code	Diag. Control	Description
0x01	0x0100	Network diagnostic data
	0x0200	Read the Ethernet port diagnostic data from the switch manager.
	0x0300	Read the Modbus TCP/port 502 diagnostic data from the Modbus server.
	0x0400	Read the Modbus TCP/port 502 connection table from the Modbus server.
	0x07F0	Read the data structure offset data from the Modbus server.
0x02	0x0100	Clears the basic network diagnostic data. <b>NOTE:</b> Only specific parameters of basic network diagnostic data are used to clear requests.
	0x0200	Clears the Ethernet port diagnostic data. <b>NOTE:</b> Only specific parameters of basic network diagnostic data are used to clear requests.

Operation Code	Diag. Control	Description
	0x0300	Clears the Modbus TCP/port 502 diagnostic data. <b>NOTE:</b> Only specific parameters of Modbus port 502 diagnostic data are used to clear requests.
	0x0400	Clears the Modbus TCP/port 502 connection table. <b>NOTE:</b> Only specific parameters of Modbus port 502 connection data are used to clear requests.
0x03	0	Clears the diagnostic data. <b>NOTE:</b> Only specific parameters of each diagnostic data are used to clear requests.

## Diagnostics Available through EtherNet/IP CIP Objects

### At a Glance

M580 applications use CIP within a producer/consumer model to provide communication services in an industrial environment. This section describes the available CIP objects for X80 modules in an M580 system.

### About CIP Objects

#### Overview

The remote I/O adapter module can access CIP data and services located in connected devices. The CIP objects and their content depend on the design of each device.

CIP object data and content are exposed and accessed hierarchically in the following nested levels:



**NOTE:** You can use explicit messaging to access these items:

- Access a collection of instance attributes by including only the class and instance values for the object in the explicit message.
- Access a single attribute by adding a specific attribute value to the explicit message with the class and instance values for the object.

When the local slave service for the adapter is activated, remote devices on the remote I/O drop can send explicit messages to the CIP object structure of the module. Then you can access module data or execute module commands.

This chapter describes the CIP objects that the adapter exposes to remote devices.

## Identity Object

### Class ID

01

### Instance IDs

The Identity object presents 2 instances:

- 0: class
- 1: instance

### Attributes

Identity object attributes are associated with each instance, as follows:

Instance ID = 0 (class attributes):

Attribute ID	Description	GET	SET
01	Revision	X	—
02	Max Instance	X	—
X = supported — = not supported			

Instance ID = 1 (instance attributes):

Attribute ID		Description	Type	GET	SET
hex	dec				
01	01	Vendor ID	UINT	X	—
02	02	Device type	UINT	X	—
03	03	Product code	UINT	X	—
04	04	Revision	STRUCT	X	—



Attribute ID		Description	Type	GET	SET
hex	dec				
		Major	USINT		
		Minor	USINT		
05	05	Status bit 2: 0x01=the module is configured bits 4-7: 0x03=no I/O connections established 0x06=at least 1 I/O connection in run mode 0x07=at least 1 I/O connection established, all in IDLE mode	Word	X	—
06	06	Serial number	UDINT	X	—
07	07	Product name	STRING	X	—
18	24	Modbus identity	STRUCT	X	—
X = supported — = not supported					

## Services

The Identity object supports the following services:

Service ID		Description	Class	Instance	Notes
hex	dec				
01	01	Get_Attributes_All	X	X	Returns: <ul style="list-style-type: none"> <li>all class attributes (instance = 0)</li> <li>instance attributes 1 to 7 (instance = 1)</li> </ul>
0E	14	Get_Attribute_Single	X	X	Returns the value of the specified attribute.
X = supported — = not supported					

## Assembly Object

### Overview

You can send an explicit message to the Assembly object only when no other connections have been established that read from or write to this object. For example, you can send an explicit message to the Assembly object if a local slave instance is enabled, but no other module is scanning that local slave.

### Class ID

04

### Instance IDs

The Assembly object presents the following instance identifiers:

- 0: class
- 101, 102, 111, 112, 121, 122: instance

### Attributes

The Assembly object consists of the following attributes:

Instance ID = 0 (class attributes):

Attribute ID	Description	GET	SET
01	Revision	X	—
02	Max Instance	X	—
03	Number of Instances	X	—
X = supported — = not supported			

Instance attributes:

Instance ID	Attribute ID	Description	Type	GET	SET
101	03	Local slave 1: T->O input data	Array of BYTE	X	—
102		Local slave 1: O>T	Array of BYTE	X	X
111		Local slave 2: T->O input data	Array of BYTE	X	—
112		Local slave 2: O>T	Array of BYTE	X	X

Instance ID	Attribute ID	Description	Type	GET	SET
121		Local slave 3: T->O input data	Array of BYTE	X	—
122		Local slave 3: O>T	Array of BYTE	X	X
X = supported — = not supported					

## Services

The Assembly object supports the following services:

Service ID		Description	Class	Instance	Notes
hex	dec				
0E	14	Get_Attribute_Single	X	X	Returns the value of the specified attribute.
10	16	Set_Attribute_Single <sup>(1)</sup>	—	X	Returns these values: 0E = attribute not settable: assembly is not o->T type 0F = permission denied: assembly is being used by an active connection 13 = config too small: the Set_Attribute_Single command contains partial data 15 = data too big: the Set_Attribute_Single command contains too much data
<p><b>(1)</b> When valid, the size of the data written to the Assembly object using the Set_Attribute_Single service equals the size of the Assembly object as configured in the target module.</p> X = supported — = not supported					

## Connection Manager Object

### Class ID

06

### Instance IDs

The Connection Manager object presents 2 instance values:

- 0: class

- 1: instance

## Attributes

Connection Manager object attributes are associated with each instance, as follows:

Instance ID = 0 (class attributes):

Attribute ID	Description	GET	SET
01	Revision	X	—
02	Max Instance	X	—
X = supported			
— = not supported			

Instance ID = 1 (instance attributes):

Attribute ID		Description	Type	GET	SET	Value
hex	dec					
01	01	Open Requests	UINT	X	X	Number of Forward Open service requests received.
02	02	Open Format Rejects	UINT	X	X	Number of Forward Open service requests that were rejected due to bad format.
03	03	Open Resource Rejects	UINT	X	X	Number of Forward Open service requests that were rejected due to lack of resources.
04	04	Open Other Rejects	UINT	X	X	Number of Forward Open service requests that were rejected for reasons other than bad format or lack of resources.
05	05	Close Requests	UINT	X	X	Number of Forward Close service requests received.
06	06	Close Format Requests	UINT	X	X	Number of Forward Close service requests that were rejected due to bad format.
07	07	Close Other Requests	UINT	X	X	Number of Forward Close service requests that were rejected for reasons other than bad format.
08	08	Connection Timeouts	UINT	X	X	Total number of connection timeouts that occurred in

Attribute ID		Description	Type	GET	SET	Value
hex	dec					
						connections controlled by this connections manager
09	09	Connection Entry List	STRUCT	X	—	0 (Unsupported optional item)
0B	11	CPU_Utilization	UINT	X	—	0 (Unsupported optional item)
0C	12	MaxBuffSize	UDINT	X	—	0 (Unsupported optional item)
0D	13	BufSize Remaining	UDINT	X	—	0 (Unsupported optional item)
X = supported — = not supported						

## Services

The Connection Manager object supports the following services:

Service ID		Description	Class	Instance	Notes
hex	dec				
01	01	Get_Attributes_All	X	X	Returns the value of all attributes.
0E	14	Get_Attribute_Single	X	X	Returns the value of the specified attribute.
X = supported — = not supported					

## Quality of Service (QoS) Object

### Overview

The QoS object implements the Differentiated Services Code Point (DSCP or *DiffServe*) values to prioritize Ethernet messages.

### Class ID

48 (hex), 72 (decimal)

## Instance IDs

The QoS object presents 2 instance values:

- 0: class
- 1: instance

## Attributes

The QoS object consists of the following attributes:

Instance ID = 0 (class attributes):

Attribute ID	Description	GET	SET
01	Revision	X	—
02	Max Instance	X	—
X = supported — = not supported			

Instance ID = 1 (instance attributes):

Attribute ID	Description	Type	GET	SET	Value
04	DSCP Urgent	USINT	X	X	For CIP transport class 0/1 Urgent priority messages, default value = 55.
05	DSCP Scheduled	USINT	X	X	For CIP transport class 0/1 Scheduled messages, default value = 47.
06	DSCP High	USINT	X	X	For CIP transport class 0/1 High priority messages, default value = 43.
07	DSCP Low	USINT	X	X	For CIP transport class 0/1 Low priority messages, default value = 31.
08	DSCP Explicit	USINT	X	X	For CIP explicit messages (transport class 2/3 and UCMM), default value = 27.
X = supported — = not supported					

**NOTE:** A change in the instance attribute value takes effect on device restart, for configurations made from flash memory.

## Services

The QoS object supports the following services:

Service ID		Description	Class	Instance
hex	dec			
0E	14	Get_Attribute_Single	X	X
10	16	Set_Attribute_Single	—	X
X = supported — = not supported				

## TCP/IP Interface Object

### Class ID

F5 (hex), 245 (decimal)

### Instance IDs

The TCP/IP interface object presents 2 instance values:

- 0: class
- 1: instance

### Attributes

TCP/IP interface object attributes are associated with each instance, as follows:

Instance ID = 0 (class attributes):

Attribute ID	Description	GET	SET
01	Revision	X	—
02	Max Instance	X	—
X = supported — = not supported			

Instance ID = 1 (instance attributes):

Attribute ID	Description	Type	GET	SET	Value
01	Status	DWORD	X	—	0x01
02	Configuration capability	DWORD	X	—	0x01 = from BootP 0x11 = from flash 0x00 = other
03	Configuration control	DWORD	X	X	0x01 = out-of-box default
04	<b>Physical Link Object</b>	<b>STRUCT</b>	X	—	
	Path size	UINT			
	Path	Padded EPATH			
05	<b>Interface Configuration</b>	<b>STRUCT</b>	X	X	0x00 = out-of-box default
	IP address	UDINT			
	Network mask	UDINT			
	Gateway address	UDINT			
	Name server	UDINT			
	Name server 2	UDINT			
	Domain name	STRING			
06	Host name	STRING	X	—	
X = supported — = not supported					

## Services

The TCP/IP interface object supports the following services:

Service ID		Description	Class	Instance	Notes
hex	dec				
01	01	Get_Attributes_All	X	X	Returns the value of all attributes.
0E	14	Get_Attribute_Single	X	X	Returns the value of the specified attribute.
10	16	Set_Attribute_Single <sup>1</sup>	—	X	Sets the value of the specified attribute.



Service ID		Description	Class	Instance	Notes
hex	dec				
X = supported — = not supported					
1. The Set_Attribute_Single service can execute only when these preconditions are satisfied: <ul style="list-style-type: none"> <li>• Configure the Ethernet communication module to obtain its IP address from flash memory.</li> <li>• Confirm that the PAC is in stop mode.</li> </ul>					

## Ethernet Link Object

### Class ID

F6 (hex), 246 (decimal)

### Instance IDs

The Ethernet Link object presents the following instance values (for an BMECRA31210):

- 0: class
- 1: port (ETH1, page 17)
- 2: port (ETH2)
- 3: port (ETH3)
- 4: port (Internal backplane port 255)

### Attributes

The Ethernet Link object presents the following attributes:

Instance ID = 0 (class attributes):

Attribute ID	Description	GET	SET
01	Revision	X	—
02	Max Instance	X	—
03	Number of Instances	X	—
X = supported — = not supported			

Instance ID = 1 (instance attributes):

Attribute ID		Description	Type	GET	SET	Value
hex	dec					
01	01	Interface speed	UDINT	X	—	Valid values include: 0, 10000000, 100000000
02	02	Interface flags	DWORD	X	—	Bit 0: link status 0 = Inactive 1 = Active
						Bit 1: duplex mode 0 = half duplex 1 = full duplex
						Bits 2—4: negotiation status 3 = successfully negotiated speed and duplex 4 = forced speed and link
						Bit 5: manual setting requires reset 0 = automatic 1 = device need reset
						Bit 6: local hardware detected error 0 = no event 1 = event detected
03	03	<b>Physical Address</b>	<b>ARRAY of 6 USINT</b>	X	—	module MAC address
04	04	<b>Interface Counters</b>	<b>STRUCT of</b>	X	—	
		In bytes	UDINT			bytes received on the interface
		In Ucast packets	UDINT			unicast packets received on the interface
		In NUcast packets	UDINT			non-unicast packets received on the interface
		In discards	UDINT			inbound packets received on the interface, but discarded
		In detected errors	UDINT			inbound packets with detected errors (does not include in discards)

Attribute ID		Description	Type	GET	SET	Value
hex	dec					
		In Unknown Protocols	UDINT			inbound packets with unknown protocol
		Out bytes	UDINT			bytes sent on the interface
		Out Ucast packets	UDINT			unicast packets sent on the interface
		Out NUcast packets	UDINT			non-unicast packets sent on the interface
		Out discards	UDINT			outbound packets discarded
		Out detected errors	UDINT			outbound packets with detected errors
05	05	<b>Media Counters</b>	<b>STRUCT</b> of	X	—	
		Detected alignment errors	UDINT			frames that are not an integral number of bytes in length
		Detected FCS errors	UDINT			incorrect CRC: frames received do not pass the FCS check
		Single collisions	UDINT			successfully transmitted frames that experienced exactly 1 collision
		Multiple collisions	UDINT			successfully transmitted frames that experienced more than 1 collision
		SQE test errors	UDINT			number of times the SQE test error is generated
		Deferred transmissions	UDINT			frames for which first transmission attempt is delayed because the medium is busy
		Late collisions	UDINT			number of times a collision is detected later than 512-bit times into the transmission of a packet
		Excessive collisions	UDINT			frames that do not transmit due to excessive collisions
		MAC transmit detected errors	UDINT			frames that do not transmit due to a detected internal MAC sublayer transmit detected error
		Frame too long	UDINT			frames received that exceed the maximum permitted frame size
05	05	Detected MAC receive errors	UDINT	X	—	frames not received on an interface due to a detected internal MAC sublayer detected receive error

Attribute ID		Description	Type	GET	SET	Value
hex	dec					
		Carrier sense detected errors	UDINT			times that the carrier sense condition was lost or not asserted when attempting to transmit a frame
06	06	<b>Interface Control</b>	<b>STRUCT</b> of	X	X	API of the connection
		Control bits	WORD			Bit 0: Auto-negotiation 0 = disabled 1 = enabled  <b>Note:</b> When auto-negotiation is enabled, 0x0C (object state conflict) is returned when attempting to set either: <ul style="list-style-type: none"> <li>forced interface speed</li> <li>forced duplex mode</li> </ul>
		Forced interface speed	UINT			Bit 1: forced duplex mode (if auto-negotiation bit = 0) 0 = half duplex 1 = full duplex  Valid values include: 10000000, 100000000  <b>Note:</b> Attempting to set any other value returns the detected error 0x09 (invalid attribute value)
10	16	Interface label	SHORT_STRING	X	—	A fixed textual string identifying the interface that should include 'internal' for internal interfaces. Maximum number of characters is 64.
X = supported — = not supported						

## Services

The Ethernet Link object supports the following services:

Service ID		Description	Class	Instance
hex	dec			
01	01	Get_Attributes_All	X	X
10	16	Set_Attribute_Single	—	X
0E	14	Get_Attribute_Single	X	X
4C	76	Get_and_Clear	—	X
X = supported — = not supported				

## EtherNet/IP Interface Diagnostics Object

### Class ID

350 (hex), 848 (decimal)

### Instance IDs

The EtherNetP/IP Interface object presents 2 instance values:

- 0: class
- 1: instance

### Attributes

EtherNet/IP Interface Diagnostics object attributes are associated with each instance, as follows:

Instance ID = 0 (class attributes):

Attribute ID	Description	GET	SET
01	Revision	X	—
02	Max Instance	X	—
X = supported — = not supported			

Instance ID = 1 (instance attributes):

Attribute ID	Description	Type	GET	SET	Values
01	Protocols Supported	UINT	X	—	0: supported 1: not supported <ul style="list-style-type: none"> <li>• Bit 1: Modbus TCP/IP</li> <li>• Bit 2: Modbus SL</li> <li>• Bits 3-15: Reserved</li> </ul>
02	<b>Connection Diagnostics</b>	<b>STRUCT</b> of	X	—	
	Max CIP I/O connections opened	UINT			Number of Class 1 connections opened since the last reset
	Current CIP I/O connections	UINT			Number of Class 1 connections currently opened.
	Max CIP explicit connections opened	UINT			Number of Class 3 connections opened since the last reset.
	Current CIP explicit connections	UINT			Number of Class 3 connections currently opened.
	CIP connections opening detected errors	UINT			Increments each time a Forward Open is not successful (Originator and Target).
	CIP connections timeout detected errors	UINT			Increments when a connection times out (Originator and Target).
	Max EIP TCP connections opened	UINT			Number of TCP connections (used for EIP as client or server) opened since the last reset.
	Current EIP TCP connections	UINT			Number of TCP connections (used for EIP as client or server) currently open.
03	<b>I/O Messaging Diagnostics</b>	<b>STRUCT</b> of	X	X	
	I/O production counter	UDINT			Increments each time a Class 0/1 message is sent.
	I/O consumption counter	UDINT			Increments each time a Class 0/1 message is received.
	I/O productions send detected error counter	UINT			Increments each time a Class 0/1 message is not sent.
	I/O consumptions receive detected error counter	UINT			Increments each time a consumption is received with a detected error.
04	<b>Explicit Messaging Diagnostics</b>	<b>STRUCT</b> of	X	X	
	Class 3 message sent counter	UDINT			Increments each time a Class 3 message is sent (client and server).
	Class 3 message received counter	UDINT			Increments each time a Class 3 message is received (client and server).

Attribute ID	Description	Type	GET	SET	Values
	UCMM message received counter	UDINT			Increments each time an UCMM message is sent (client and server).
	UCMM message received counter	UDINT			Increments each time an UCMM message is received (client and server).
X = supported — = not supported					

## Services

The EtherNet/IP Interface Diagnostics object supports the following services:

Service ID		Description	Class	Instance	Notes
hex	dec				
01	01	Get_Attributes_All	X	X	Returns the value of all attributes.
0E	14	Get_Attribute_Single	—	X	Returns the value of the specified attribute.
4C	76	Get_and_Clear	—	X	Returns and clears the values of all instance attributes.
X = supported — = not supported					

## I/O Connection Diagnostics Object

### Class ID

352 (hex), 850 (decimal)

### Instance IDs

The I/O Connection Diagnostics object presents the following instance values:

- 0: class
- 1...256: instances

**NOTE:** The Instance ID number = the Connection ID. For M580 specifically, you can look up the Connection ID on the DTM Device List screen.

## Attributes

I/O Connection Diagnostics object attributes are associated with each instance, as follows:

Instance ID = 0 (class attributes):

Attribute ID	Description	GET	SET
01	Revision	X	—
02	Max Instance	X	—
X = supported — = not supported			

Instance ID = 1 to 256 (instance attributes):

Attribute ID	Description	Type	GET	SET	Value
01	<b>I/O Communication Diagnostics</b>	<b>STRUCT</b> of	X	X	
	I/O production counter	UDINT			Increments at each production.
	I/O consumption counter	UDINT			Increments at each consumption.
	I/O production sent detected error counter	UINT			Increments each time a production is not sent.
	I/O consumption received detected errors counter	UINT			Increments each time a consumption is received with a detected error.
	CIP connection timeout detected errors	UINT			Increments when a connection times out.
	CIP connection opening detected errors	UINT			Increments each time a connection is unable to open.
	CIP connection state	UINT			State of the connection bit
	CIP last detected error general status	UINT			General status of the last error detected on the connection
	CIP last detected error extended status	UINT			Extended status of the last error detected on the connection
	Input communication status	UINT			Communication status of the inputs (see table, below)
	Output communication status	UINT			Communication status of the outputs (see table, below)
02	<b>Connection Diagnostics</b>	<b>STRUCT</b> of	X	X	
	Production connection ID	UDINT			Connection ID for production
	Consumption connection ID	UDINT			Connection ID for consumption



Attribute ID	Description	Type	GET	SET	Value
	Production RPI	UDINT			RPI for production (ms)
	Production API	UDINT			API for production
	Consumption RPI	UDINT			RPI for consumption
	Consumption API	UDINT			API for consumption
	Production connection parameters	UDINT			Connection parameters for production
	Consumption connection parameters	UDINT			Connection parameters for consumption <b>NOTE:</b> Refer to the ODVA standard: The CIP Networks Library Vol. 1: Common Industrial Protocol Publication number: PUB00001
	Local IP	UDINT			—
	Local UDP port	UINT			—
	Remote IP	UDINT			—
	Remote UDP port	UINT			—
	Production multicast IP	UDINT			Multicast IP address used for production. If unused, it is 0.
	Consumption multicast IP	UDINT			Multicast IP address used for consumption. If unused, it is 0.
	Protocols supported	UDINT			Protocols supported on the connection: 1 = EtherNet/IP

X = supported  
 — = not supported

The following values describe the structure of the instance attributes: *CIP connection state*, *Input Communication status*, and *Output communication status*:

Bit Number	Description	Values
15...3	<i>Reserved</i>	0
2	Idle	0 = no idle notification 1 = idle notification

Bit Number	Description	Values
1	Consumption inhibited	0 = consumption started 1 = no consumption
0	Production inhibited	0 = production started 1 = no production

## Services

The EtherNet/IP Interface Diagnostics object supports the following services:

Service ID		Description	Class	Instance	Notes
hex	dec				
01	01	Get_Attributes_All	X	X	Returns the value of all attributes.
0E	14	Get_Attribute_Single	—	X	Returns the value of the specified attribute.
4C	76	Get_and_Clear	—	X	Returns and clears the values of all instance attributes.
X = supported — = not supported					

## EtherNet/IP Explicit Connection Diagnostics Object

### Overview

The EtherNet/IP Explicit Connection Diagnostics object presents the instances, attributes and services described below.

### Class ID

353 (hex), 851 (decimal)

### Instance IDs

The EtherNet/IP Explicit Connection Diagnostics object presents two instance values:

- 0: class
- 1...N: instance (N = maximum concurrent number of explicit connections)

## Attributes

EtherNet/IP Explicit Connection Diagnostics object attributes are associated with each instance, as follows:

Instance ID = 0 (class attributes):

Attribute ID hex	Description	Value	GET	SET
01	Revision	1	X	—
02	Max Instance	0...N	X	—
X = supported — = not supported				

Instance ID = 1 to N (instance attributes):

Attribute ID hex	Description	Type	GET	SET	Value
01	Originator connection ID	UDINT	X	—	Originator to target connection ID
02	Originator IP	UINT	X	—	
03	Originator TCP Port	UDINT	X	—	
04	Target connection ID	UDINT	X	—	Target to originator connection ID
05	Target IP	UDINT	X	—	
06	Target TCP Port	UDINT	X	—	
07	Msg Send Counter	UDINT	X	—	Incremented each time a Class 3 CIP message is sent on the connection
08	Msg Receive counter	UDINT	X	—	Increments each time a Class 3 CIP message is received on the connection
X = supported — = not supported					

## Services

The EtherNet/IP Explicit Connection Diagnostics object performs the following services upon the listed object type:

Service ID		Description	Class	Instance	Notes
hex	dec				
01	01	Get_Attributes_All	X	X	Returns the value of all attributes.
X = supported — = not supported					

## EtherNet/IP Explicit Connection Diagnostics List Object

### Overview

The EtherNet/IP Explicit Connection Diagnostics List object presents the instances, attributes and services described below.

### Class ID

354 (hex), 852 (decimal)

### Instance IDs

The EtherNet/IP Explicit Connection Diagnostics List object presents two instance values:

- 0: class
- 1: instance

### Attributes

EtherNet/IP Explicit Connection Diagnostics List object attributes are associated with each instance, as follows:

Instance ID = 0 (class attributes):

Attribute ID	Description	GET	SET
01	Revision	X	—
02	Max Instance	X	—
X = supported — = not supported			

Instance ID = 1 to 2 (instance attributes):

Attribute ID	Description	Type	GET	SET	Value
01	Number of connections	UINT	X	—	Total number of opened explicit connections
02	Explicit Messaging Connections Diagnostic List	ARRAY of STRUCT	X	—	
	Originator connection ID	UDINT			O->T connection ID
	Originator IP	UINT			—
	Originator TCP port	UDINT			—
	Target connection ID	UDINT			T->O connection ID
	Target IP	UDINT			—
	Target TCP port	UDINT			—
	Msg Send counter	UDINT			Increments each time a Class 3 CIP message is sent on the connection
	Msg Receive counter	UDINT			Increments each time a Class 3 CIP message is received on the connection
X = supported — = not supported					

## Services

The EtherNet/IP Explicit Connection Diagnostics object performs the following services upon the listed object types:

Service ID		Description	Class	Instance	Notes
hex	dec				
01	01	Get_Attributes_All	X	—	Returns the value of all attributes.
08	08	Create	X	—	—
09	09	Delete	—	X	—
4B	75	Explicit_Connections_Diagnostic_Read	—	X	—
X = supported — = not supported					

## RSTP Diagnostics Object

### Class ID

355 (hex), 853 (decimal)

### Instance IDs

The RSTP Diagnostics object presents these instance values:

- 0: class
- 1... N: instance

### Attributes

RSTP Diagnostics object attributes are associated with each instance.

Instance ID = 0 (class attributes):

Attribute ID	Description	Type	GET	SET
01	Revision: This attribute specifies the current revision of the RSTP Diagnostic object. The revision is increased by 1 at each new update of the object.	UINT	X	—
02	Max Instance: This attribute specifies the maximum number of instances that may be created for this object on a per device basis (for example, an RSTP bridge). There is 1 instance for each RSTP port on a device.	UINT	X	—
X = supported — = not supported				

Instance ID = 1 to N (instance attributes):

Attribute ID	Description	Type	GET	CLEAR	Value
01	<b>Switch status</b>	<b>STRUCT</b> of	X	—	—
	Protocol specification	UINT	X	—	Refer to RFC-4188 for attribute definitions and value range. In addition, the following value is defined: [4]: the protocol is IEEE 802.1D-2004 and IEEE 802.1W.
	Bridge priority	UDINT	X	—	Refer to RFC-4188 for attribute definitions and value range.
	Time since topology change	UDINT	X	—	

Attribute ID	Description	Type	GET	CLEAR	Value
	Topology change count	UDINT	X	—	Refer to RFC-4188 for attribute definitions and value range.
	Designated root	String	X	—	
	Root cost	UDINT	X	—	
	Root port	UDINT	X	—	
	Maximum age	UINT	X	—	
	Hello time	UINT	X	—	
	Hold time	UDINT	X	—	
	Forward delay	UINT	X	—	
	Bridge maximum age	UINT	X	—	
	Bridge hello time	UINT	X	—	
	Bridge forward delay	UINT	X	—	
02	<b>Port status</b>	STRUCT	X	X	—
	Port	UDINT	X	X	Refer to RFC-4188 for attribute definitions and value range.
	Priority	UDINT	X	X	
	State	UINT	X	X	
	Enable	UINT	X	X	
	Path cost	UDINT	X	X	
	Designated root	String	X	X	
	Designated cost	UDINT	X	X	
	Designated bridge	String	X	X	
	Designated port	String	X	X	
	Forward transitions count	UDINT	X	X	
03	<b>Port mode</b>	STRUCT of	X	—	—
	Port number	UINT	X	—	This attribute indicates the port number for a data query. The value range is

Attribute ID	Description	Type	GET	CLEAR	Value
					configuration-dependent. For a 4-port Ethernet device, as an instance, the valid range is 1...4.
	Admin edge port	UINT	X	—	This attribute indicates if this is a user-configured edge port: <ul style="list-style-type: none"> <li>• 1: true</li> <li>• 2: false</li> </ul> Other values are not valid.
	Operator edge port	UINT	X	—	This attribute indicates if this port is an edge port: <ul style="list-style-type: none"> <li>• 1: true</li> <li>• 2: false</li> </ul> Other values are not valid.
	Auto edge port	UINT	X	—	This attribute indicates if this port is a dynamically determined edge port: <ul style="list-style-type: none"> <li>• 1: true</li> <li>• 2: false</li> </ul> Other values are not valid.
X = supported — = not supported					

## Services

The RSTP Diagnostics object performs these services:

Service ID		Description	Class	Instance	Notes
hex	dec				
01	01	Get_Attributes_All	X	X	This service returns: <ul style="list-style-type: none"> <li>• all attributes of the class</li> <li>• all attributes of the instance of the object</li> </ul>
02	02	Get_Attribute_Single	X	X	This service returns: <ul style="list-style-type: none"> <li>• the contents of a single attribute of the class</li> <li>• the contents of the instance of the object as specified</li> </ul> Specify the attribute ID in the request for this service.



Service ID		Description	Class	Instance	Notes
hex	dec				
32	50	Get_and_Clear	—	X	This service returns the contents of a single attribute of the instance of the object as specified. Then the relevant counter-like parameters within the specified attribute are cleared. (Specify the attribute ID in the request for this service.)
X = supported — = not supported					

## Service Port Control Object

### Class ID

400 (hex), 1024 (decimal)

### Instance IDs

The Service Port Control object presents these instance values:

- 0: class
- 1: instance

### Attributes

Service Port Control object attributes are associated with each instance.

Required class attributes (instance 0):

Attribute ID	Description	Type	Get	Set
01	Revision	UINT	X	—
02	Max Instance	UINT	X	—
X = supported — = not supported				

Required instance attributes (instance 1):

Attribute ID		Description	Type	Get	Set	Value
hex	dec					
01	01	Port control	UINT	X	X	0 (default): disabled 1: access port 2: port mirroring 3: extended port
02	02	Mirror	UINT	X	X	bit 0 (default): ETH2 port bit 1: ETH3 port bit 2: ETH4 port bit 3: internal port
X = supported — = not supported						

**NOTE:**

- If the SERVICE port is not configured for port mirroring, the mirror attribute is ignored. If the value of a parameter request is outside the valid range, the service request is ignored.
- In port mirroring mode, the SERVICE port acts like a read-only port. That is, you cannot access devices (ping, connection to Control Expert, and so on) through the SERVICE port.

## Services

The Service Port Control object supports these services:

Service ID		Name	Class	Instance	Description
hex	dec				
01	01	Get_Attributes_All	X	X	Get all attributes in a single message.
02	02	Set_Attributes_All	—	X	Set all attributes in a single message.
0E	14	Get_Attribute_Single	X	X	Get a single specified attribute.
10	16	Set_Attribute_Single	—	X	Set a single specified attribute.
X = supported — = not supported					

## SNTP Diagnostics Object

### Class ID

405 (hex), 1029 (decimal)

### Instance IDs

The SNTP diagnostics list object presents the following instance values:

- 0: class
- 1: instance

### Attributes

SNTP diagnostics object attributes are associated with each instance.

Instance ID = 0 (class attributes):

Attribute ID	Description	GET	SET
01	Revision: Increased by 1 at each new update of the object	X	—
02	Max Instance: Maximum number of instances of the object	X	—
<p><b>NOTE:</b> All attributes are required in the implementation.</p> <p>X = supported</p> <p>— = not supported</p>			

Instance ID = 1 (instance attribute):

Attribute ID (hex)	Description	Type	GET	SET	Value
01	<b>Network Time Service Configuration</b>	<b>STRUCT</b> of:	X	—	
	Primary NTP server IP address	UDINT			
	Polling period	USINT			In seconds
	Update CPU with module time	USINT			<ul style="list-style-type: none"> <li>• 0: Do not update CPU time.</li> <li>• 1: Update CPU time.</li> </ul>
	Time zone	UDINT			Depends on the operating system of the configuration software. Refer to reference DTM Requirements.

Attribute ID (hex)	Description	Type	GET	SET	Value
	Time zone offset	INT			In minutes
	Daylight saving time bias	USINT			
	Daylight saving start date - month	USINT			
	Daylight saving start date-week, day of week	USINT			MSB (4 bits): week number LSB (4 bits): <ul style="list-style-type: none"> <li>• 0: Sunday</li> <li>• 1: Monday</li> <li>• ...</li> <li>• 6: Saturday</li> </ul>
	Daylight saving start time	UDINT			Seconds elapsed since midnight
	Daylight saving end date - month	USINT			
	Daylight saving end date - week, day of week	USINT			MSB (4 bits): week number LSB (4 bits): <ul style="list-style-type: none"> <li>• 0: Sunday</li> <li>• 1: Monday</li> <li>• ...</li> <li>• 6: Saturday</li> </ul>
	Daylight saving end time	UDINT			Seconds elapsed since midnight
	Reserved	UDINT[15]			
2	Network time service status	UDINT	X	—	<ul style="list-style-type: none"> <li>• 1: Idle</li> <li>• 2: Operational</li> </ul>
3	Link to NTP server status	UDINT	X	—	<ul style="list-style-type: none"> <li>• 1: NTP server cannot be reached.</li> <li>• 2: NTP server can be reached.</li> </ul>
4	Current NTP server IP address	UDINT	X	—	
5	NTP server type	UDINT	X	—	Corresponds to the server identified in attribute 3: <ul style="list-style-type: none"> <li>• 1: Primary</li> <li>• 2: Secondary</li> </ul>
6	NTP server time quality	UDINT	X	—	Current jitter of the clock/time in microseconds/second
7	Number of NTP requests sent	UDINT	X	—	

Attribute ID (hex)	Description	Type	GET	SET	Value
8	Number of detected communication detected errors	UDINT	X	—	
9	Number of NTP responses received	UDINT	X	—	
A	Last detected error	UINT	X	—	<ul style="list-style-type: none"> <li>0: NTP_NO_ERROR</li> <li>1: NTP_ERROR_CONF_BAD_PARAM</li> <li>2: NTP_ERROR_CONF_BAS_CONF</li> <li>3: NTP_ERROR_CREATE_SERVICE</li> <li>4: NTP_ERROR_WRONG_STATE</li> <li>5: NTP_ERROR_NO_RESPONSE</li> </ul>
B	Current date and time	DATE_AND_TIME	X	—	{time_of_day UDINT, date UINT} (see CIP specification)
C	Daylight savings status	UDINT	X	—	<ul style="list-style-type: none"> <li>1: Daylight savings are enabled and the current date/time is within the applicable period.</li> <li>2: NTP daylight savings are not enabled or enabled but not within the applicable period.</li> </ul>
D	Time since last update	DINT	X	—	Amount of time elapsed since a valid response from the NTP server (in 100 ms increments) -1: not updated
<p><b>NOTE:</b> All attributes are required in the implementation.</p> <p>X = supported</p> <p>— = not supported</p>					

## Services

The SNTP diagnostics object support the following services:

Service ID		Description	Class	Instance	Notes
hex	dec				
01	01	Get_Attributes_All	Required	Required	To gather all attributes into one message
0E	14	Get_Attribute_Single	Required	Required	To get a single specified attribute

Service ID		Description	Class	Instance	Notes
hex	dec				
32	50	Clear_All	—	Required	Clears data in attributes: 6, 7, 8, 9, 10, 13
X = supported — = not supported					

## Ethernet Backplane Diagnostics Object

### Class ID

407 (hex), 1031(decimal)

### Instance IDs

The Ethernet Backplane Diagnostics object presents the following instance values:

- 0: class
- 1: instance

### Attributes

Ethernet Backplane Diagnostics object attributes are associated with each instance, as follows:

Instance ID = 0 (class attributes):

Attribute ID hex	Needed in Implementation	Description	Value	Data Type	GET
01	Required	Revision of this object	The current value assigned to this attribute is 1.	UNIT	X
02	Conditional <sup>(1)</sup>	Maximum instances	The largest number of instances of a created object at this class hierarchy level.	UNIT	X
03	Conditional <sup>(1)</sup>	Number of instances	The number of object instances at this class hierarchy level.	UNIT	X

<sup>(1)</sup> Required if the number of instances is greater than 1

X = supported

Instance ID = 1 (instance attributes):

Attribute ID hex	Needed in Implementation	Description	Type	NV	GET	Value
01	Required	Backplane Ethernet port status (link status/health of each module on the backplane)	UINT	V	X	Refer to Attribute 1 below.
02	Required	Extended health (status) of Ethernet backplane	UINT	V	X	Refer to Attribute 2 below.
02	Conditional <sup>(1)</sup>	<b>Connection Diagnostics</b>	<b>STRUCT of</b>		X	
		Maximum CIP I/O connections opened	UINT			Number of Class 1 connections opened since the last reset
	Needed in implementation	Current CIP I/O connections	UINT			Number of Class 1 connections currently opened.
	Required	Maximum CIP explicit connections opened	UINT			Number of Class 3 connections opened since the last reset.
	Conditional <sup>(1)</sup>	Current CIP explicit connections	UINT			Number of Class 3 connections currently opened.
	Conditional <sup>(1)</sup>	CIP detected connections opening errors	UINT			Increments each time a Forward Open is not successful (Originator and Target).
		CIP detected connection timeout errors	UINT			Increments when a connection times out (Originator and Target).
	Needed in implementation	Maximum EIP TCP connections opened	UINT			Number of TCP connections (used for EIP as client or server) opened since the last reset.
	Required	Current EIP TCP connections	UINT			Number of TCP connections (used for EIP as client or server) currently open.
03	Conditional <sup>(1)</sup>	<b>I/O Messaging Diagnostics</b>	<b>STRUCT of</b>		X	

Attribute ID hex	Needed in Implementation	Description	Type	NV	GET	Value
	Conditional <sup>(1)</sup>	I/O production counter	UDINT			Increments each time a Class 0/1 message is sent.
		I/O consumption counter	UDINT			Increments each time a Class 0/1 message is received.
	Needed in implementation	I/O detected production sent errors counter	UINT			Increments each time a Class 0/1 message is not sent.
	Required	I/O detected consumption receive errors counter	UINT			Increments each time a consumption is received with a detected error.
04	Conditional <sup>(1)</sup>	<b>Explicit Messaging Diagnostics</b>	<b>STRUCT</b> of		X	
	Conditional <sup>(1)</sup>	Class 3 messages sent counter	UDINT			Increments each time a Class 3 message is sent (client and server).
		Class 3 messages received counter	UDINT			Increments each time a Class 3 message is received (client and server).
	Needed in implementation	UCMM messages sent counter	UDINT			Increments each time a UCMM message is sent (client and server).
	Required	UCMM messages received counter	UDINT			Increments each time a UCMM message is received (client and server).
<p><b>(1)</b> Required if the number of instances is greater than 1                      X = supported</p>						



# Diagnostics Available through Control Expert

## Introduction to Control Expert Diagnostics

### Introduction

The Modicon M580 modules support online actions.

### Tasks

Use online actions to perform these tasks:

- Display EtherNet/IP objects for a remote EtherNet/IP device.
- Ping the CPU remote I/O scanner module, a remote EtherNet/IP, or a Modbus TCP device to confirm it is active on the Ethernet network.
- Connect to a remote device to perform these actions:
  - View the remote device's default parameter settings.
  - View the remote device's current parameter settings.
  - Edit and download to the remote device its editable parameter settings.

## Displaying I/O Memory Consumption

### Displaying Memory Consumption

In Control Expert you can monitor the I/O memory consumption by viewing the adapter properties. In the **Project Browser**, double-click **Configuration > EIO Bus > Modicon M580 remote drop**. Then right-click **Modicon M580 remote drop** and select **Properties**.

This is an example of an **IO-Memory** tab:

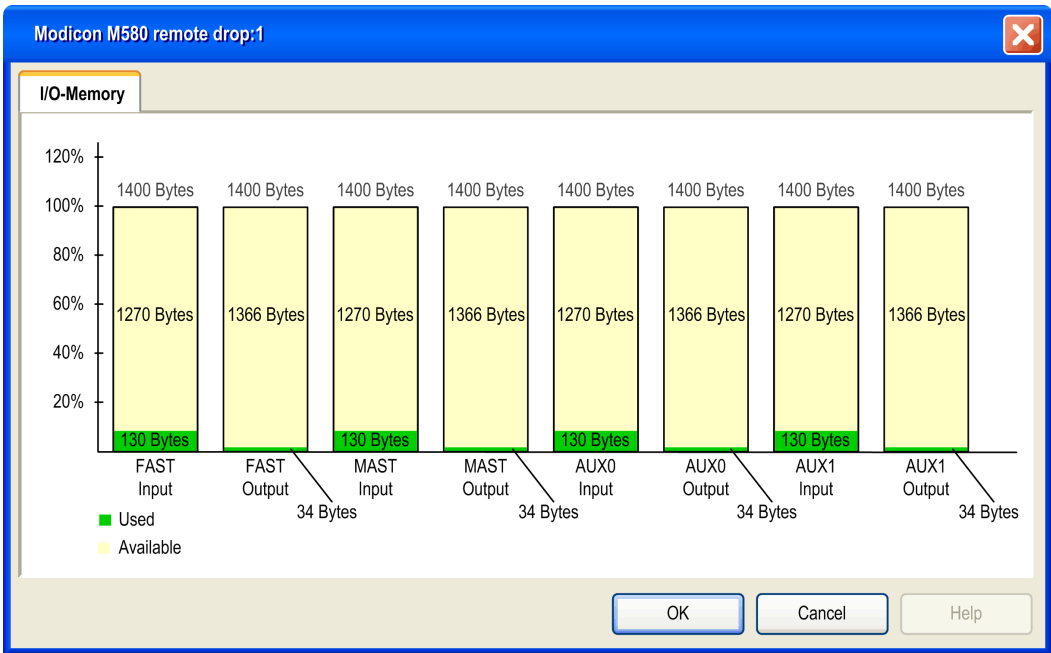

**NOTE:** Quantum 140CRA31200 adapter modules *do not* support FAST and AUX0/AUX1 tasks. BMCRA312•0 adapter modules do.

### Exceeding EIO Limitations

Control Expert displays a detected **error** in the log window if one of these events occurs:

- The size of the RIO drop memory for the MAST task exceeds 1400 input bytes or 1400 output bytes.
- The size of the RIO drop memory for the FAST task exceeds 1400 input bytes or 1400 output bytes.
- The size of the RIO drop memory for an AUX task exceeds 1400 input bytes or 1400 output bytes.

**NOTE:** Modicon M580 BMCRA312•0 adapter modules support FAST and AUX• tasks (see Quantum EIO, Remote I/O Modules, Installation and Configuration Guide). Quantum 140CRA31200 adapter modules do not.

# Firmware Update

## Introduction

This chapter describes the steps for updating the firmware for your adapter module.

## Firmware Update with Automation Device Maintenance

### Overview

The EcoStruxure™ Automation Device Maintenance is a standalone tool that allows and simplifies the firmware update of devices in a plant (single or multiple).

The tool supports the following features:

- Automatic device discovery
- Manual device identification
- Certificate management
- Firmware update for multiple devices simultaneously

**NOTE:** For a description of the download procedure, refer to the *EcoStruxure™ Automation Device Maintenance, User Guide*.

## EIO Adapter Firmware Update with Unity Loader

### Overview

Use these procedures to update the firmware for the EIO adapter:

Stage	Description
1	Download and install Unity Loader software.
2	Configure and store IP parameters (optional).
3	Connect your configuration PC to the EIO adapter.
4	Transfer the firmware update to the EIO adapter or the Ethernet backplane.

The minimum required version of Unity Loader is V8.0.

These instructions apply to the BMXCRA31200, BMXCRA31210, BMECRA31210, and 140CRA31908 modules.

## Downloading and Installing Unity Loader

Download the Unity Loader software to your PC:

Step	Action
1	Enter the web address for Schneider Electric ( <a href="http://www.se.com">www.se.com</a> ) in an Internet browser.
2	In the <b>Search from input field</b> , enter the phrase <b>Unity Loader</b> and press <code>Enter</code> .
3	Examine the search results and select the appropriate entry for the Unity Loader software.
4	Follow the on-screen instructions to download both the Unity Loader installation software and any necessary installation instructions.
5	Run the Unity Loader setup file and follow the instructions (on the screen and in the downloaded documentation) to install Unity Loader.

## Default Address Configurations

If the CRA IP address is not configured, you can temporarily use its default IP address by setting the rotary switch to Stored. This default IP address is overwritten when you configure and store valid IP parameters.

The adapter uses these default address configurations:

Parameter	Description
Default IP Address	The default IP address starts with 10.10 and uses the last 2 bytes of the MAC address. As an example, a device with the MAC address of 00:00:54:10:8A:05 has a default IP address of 10.10.138.5 (0x8A=138, 0x05=5).
Default Sub-Network Mask	The default mask is 255.0.0.0 (a class A mask).
Default Gateway Address	The default gateway address is identical to the default IP address.

The default address is based on the adapter MAC address. This makes it possible for several Schneider Electric devices to use their default network configurations on the same network.

To configure and store IP parameters that are not the default values for the remote drop adapter:

Step	Action
1	Start or re-start the adapter with the rotary switch set to <b>Stored</b> .
2	Store the IP address by sending an explicit message to the TCP/IP Interface Object, page 79 (Attribute ID 05: Interface Configuration).

**NOTE:** The adapter uses the stored IP parameters only after a power cycle.

## Connect the Configuration PC to the EIO Adapter

Connect your configuration PC (that is running Unity Loader) directly to the adapter module via an Ethernet port.

Verify that communications are established between the PC and the adapter by issuing a ping command from the PC:

Step	Action	Comment
1	Open a command window on the PC.	<b>Start &gt; Run.</b>
2	In the <b>Run</b> dialog, type in <b>cmd</b> .	
3	Click <b>OK</b> .	
4	At the command prompt, type in the ping command and the device IP address.	Example: C:\>ping 192.168.21.38:
5	The command window verifies that a connection is established.	Example: Reply from 192.168.21.38...

## Update Procedure

Do not interrupt the firmware download process by:

- allowing an interruption to the power or communications
- closing the Unity Loader software

If the firmware download process is interrupted, the new firmware is not installed and the adapter continues to use the old firmware. If an interruption occurs, restart the process.

**NOTE:** If the download is not completed, there is a message saying that the update was unsuccessful.

To update the firmware for the EIO adapter:

Step	Action
1	Open Unity Loader on your PC. ( <b>Start &gt; Programs &gt; Schneider Electric &gt; Unity Loader</b> ) <b>Result:</b> Unity Loader opens and displays the <b>Project</b> tab.
2	At the bottom of the tab in the <b>Connection</b> area, connect to the module: <ul style="list-style-type: none"> <li>• In the <b>Media</b> list, select <b>Ethernet</b>.</li> <li>• In the <b>Address</b> field, type in the IP address of the adapter, which is either:                             <ul style="list-style-type: none"> <li>◦ <i>configured</i>: The adapter is already communicating on the network and the IP address for the module is configured in the application in the BME•58••40 CPU module.</li> <li>◦ <i>default</i>: The adapter rotary switch position is <b>Stored</b> and you did not already store valid IP parameters.</li> </ul> </li> <li>• Click <b>Connect</b>.</li> </ul>
3	After Unity Loader has connected to the module, click the <b>Firmware</b> tab in the <b>Unity Loader</b> dialog.
4	In the <b>PC</b> area, click the ellipsis (...) button to open a dialog where you can navigate to and select the firmware file for the adapter module. The firmware is contained in a Unity Loader file (.LDX extension). <b>NOTE:</b> When using the BMECRA31210, you can also update firmware for a BMEXBP••00. After you select the firmware file and close the dialog, the selected revision of this firmware is displayed in the list on the left, and the current version of the firmware is displayed in the list on the right.
5	When the arrow in the middle of the <b>Unity Loader</b> dialog is green, click <b>Transfer</b> . <b>NOTE:</b> Only click <b>Transfer</b> if the arrow is green. A yellow arrow indicates that the firmware file on your computer is the same version or newer than the file selected for transfer; a red arrow indicates that the firmware on the computer is not compatible with the EIO adapter.
6	Click <b>Yes</b> on the 2 dialogs that appear.
7	The <b>Transferring data to PLC</b> opens, which indicates the transfer status with the blue bars at the bottom of the screen.
8	After the transfer is complete, click <b>Close</b> .
9	In the Unity Loader software, click <b>Disconnect</b> and close the window.
10	Reboot the module to finalize the firmware update.

From 1 instance of Unity Loader, you can only update 1 device. To update several devices at the same time, open additional instances of Unity Loader. In this case, additional dialogs. Click **Yes** to close each dialog.

The update process takes approximately 3 minutes:

- firmware update (approximately 2 minutes)
- reboot, reestablish I/O connections (1 minute)

During the firmware update, the I/O communication with the adapter module is interrupted. After the hold up time, page 54 expires, the output modules move to the pre-configured fallback setting (a value of 0, 1, or hold last value).

---

# Glossary

## A

### **adapter:**

An adapter is the target of real-time I/O data connection requests from scanners. It cannot send or receive real-time I/O data unless it is configured to do so by a scanner, and it does not store or originate the data communications parameters necessary to establish the connection. An adapter accepts explicit message requests (connected and unconnected) from other devices.

### **AUX:**

An (AUX) task is an optional, periodic processor task that is run through its programming software. The AUX task is used to execute a part of the application requiring a low priority. This task is executed only if the MAST and FAST tasks have nothing to execute. The AUX task has two sections:

- IN: Inputs are copied to the IN section before execution of the AUX task.
- OUT: Outputs are copied to the OUT section after execution of the AUX task.

## B

### **broadcast:**

A message sent to all devices in a broadcast domain.

## C

### **CCOTF:**

*(change configuration on the fly)* A feature of Control Expert that allows a module hardware change in the system configuration while the system is operating. This change does not impact active operations.

### **CIP™:**

*(common industrial protocol)* A comprehensive suite of messages and services for the collection of manufacturing automation applications (control, safety, synchronization, motion, configuration and information). CIP allows users to integrate these manufacturing applications with enterprise-level Ethernet networks and the internet. CIP is the core protocol of EtherNet/IP.

**CPU:**

(*central processing unit*) The CPU, also known as the processor or controller, is the brain of an industrial manufacturing process. It automates a process as opposed to relay control systems. CPUs are computers suited to survive the harsh conditions of an industrial environment.

**D****DDT:**

(*derived data type*) A derived data type is a set of elements with the same type (`ARRAY`) or with different types (structure).

**determinism:**

For a defined application and architecture, you can predict that the delay between an event (change of value of an input) and the corresponding change of a controller output is a finite time  $t$ , smaller than the deadline required by your process.

**DRS:**

(*dual-ring switch*) A ConneXium extended managed switch that has been configured to operate on an Ethernet network. Predefined configuration files are provided by Schneider Electric to be downloaded to a DRS to support the special features of the main ring / sub-ring architecture.

**E****EtherNet/IP™:**

A network communication protocol for industrial automation applications that combines the standard internet transmission protocols of TCP/IP and UDP with the application layer common industrial protocol (CIP) to support both high speed data exchange and industrial control. EtherNet/IP employs electronic data sheets (EDS) to classify each network device and its functionality.

**Ethernet:**

A 10 Mb/s, 100 Mb/s, or 1 Gb/s, CSMA/CD, frame-based LAN that can run over copper twisted pair or fiber optic cable, or wireless. The IEEE standard 802.3 defines the rules for configuring a wired Ethernet network; the IEEE standard 802.11 defines the rules for configuring a wireless Ethernet network. Common forms include 10BASE-T, 100BASE-TX, and 1000BASE-T, which can utilize category 5e copper twisted pair cables and RJ45 modular connectors.



**explicit messaging:**

TCP/IP-based messaging for Modbus TCP and EtherNet/IP. It is used for point-to-point, client/server messages that include both data, typically unscheduled information between a client and a server, and routing information. In EtherNet/IP, explicit messaging is considered class 3 type messaging, and can be connection-based or connectionless.

**F****FAST:**

A FAST task is an optional, periodic processor task that identifies high priority, multiple scan requests, which is run through its programming software. A FAST task can schedule selected I/O modules to have their logic solved more than once per scan. The FAST task has two sections:

- IN: Inputs are copied to the IN section before execution of the FAST task.
- OUT: Outputs are copied to the OUT section after execution of the FAST task.

**I****implicit messaging:**

UDP/IP-based class 1 connected messaging for EtherNet/IP. Implicit messaging maintains an open connection for the scheduled transfer of control data between a producer and consumer. Because an open connection is maintained, each message contains primarily data, without the overhead of object information, plus a connection identifier.

**IP address:**

The 32-bit identifier, consisting of both a network address and a host address assigned to a device connected to a TCP/IP network.

**M****MAST:**

A master (MAST) task is a deterministic processor task that is run through its programming software. The MAST task schedules the RIO module logic to be solved in every I/O scan. The MAST task has two sections:

- IN: Inputs are copied to the IN section before execution of the MAST task.
- OUT: Outputs are copied to the OUT section after execution of the MAST task.

**multicast:**

A special form of broadcast where copies of the packet are delivered to only a specified subset of network destinations. Implicit messaging typically uses multicast format for communications in an EtherNet/IP network.

## P

### **PAC:**

*programmable automation controller*. The PAC is the brain of an industrial manufacturing process. It automates a process as opposed to relay control systems. PACs are computers suited to survive the harsh conditions of an industrial environment.

### **port 502:**

Port 502 of the TCP/IP stack is the well-known port that is reserved for Modbus TCP communications.

### **port mirroring:**

In this mode, data traffic that is related to the source port on a network switch is copied to another destination port. This allows a connected management tool to monitor and analyze the traffic.

## R

### **RIO drop:**

One of the three types of RIO modules in an Ethernet RIO network. An RIO drop is an M580 rack of I/O modules that are connected to an Ethernet RIO network and managed by an Ethernet RIO adapter module. A drop can be a single rack or a main rack with an extended rack.

### **RIO network:**

An Ethernet-based network that contains 3 types of RIO devices: a local rack, an RIO drop, and a ConneXium extended dual-ring switch (DRS). Distributed equipment may also participate in an RIO network via connection to DRSs or BMENOS0300 network option switch modules.

### **RSTP:**

*(rapid spanning tree protocol)* Allows a network design to include spare (redundant) links to provide automatic backup paths if an active link stops working, without the need for loops or manual enabling/disabling of backup links.

---

## S

### service port:

A dedicated Ethernet port on the M580 RIO modules. The port may support these major functions (depending on the module type):

- port mirroring: for diagnostic use
- access: for connecting HMI/Control Expert/ConneXview to the CPU
- extended: to extend the device network to another subnet
- disabled: disables the port, no traffic is forwarded in this mode

## T

### TCP/IP:

Also known as *internet protocol suite*, TCP/IP is a collection of protocols used to conduct transactions on a network. The suite takes its name from two commonly used protocols: transmission control protocol and internet protocol. TCP/IP is a connection-oriented protocol that is used by Modbus TCP and EtherNet/IP for explicit messaging.

### TCP:

(*transmission control protocol*) A key protocol of the internet protocol suite that supports connection-oriented communications, by establishing the connection necessary to transmit an ordered sequence of data over the same communication path.

### trap:

A trap is an event directed by an SNMP agent that indicates one of these events:

- A change has occurred in the status of an agent.
- An unauthorized SNMP manager device has attempted to get data from (or change data on) an SNMP agent.

## U

### UDP:

(*user datagram protocol*) A transport layer protocol that supports connectionless communications. Applications running on networked nodes can use UDP to send datagrams to one another. Unlike TCP, UDP does not include preliminary communication to establish data paths or provide data ordering and checking. However, by avoiding the overhead required to provide these features, UDP is faster than TCP. UDP may be the preferred protocol for time-sensitive applications, where dropped datagrams are preferable to delayed datagrams. UDP is the primary transport for implicit messaging in EtherNet/IP.



# Index

140CRA31908	
grounding.....	38
installation.....	38
<b>A</b>	
assembly object.....	74
AUX0 task.....	64
AUX1 task.....	64
<b>B</b>	
backplane considerations.....	36
BMECRA31210	
Control Expert configuration.....	47, 50, 53
description.....	14, 21
external features.....	17
firmware update.....	107
firmware upgrade.....	107
functionality.....	16
grounding.....	38
installation.....	35, 38
Modbus diagnostic codes.....	70
NTP configuration.....	14
rack extension.....	37
BMECRA31210C	
description.....	14
BMXCRA31200	
Control Expert configuration.....	47, 50, 53
description.....	14, 21
firmware update.....	107
firmware upgrade.....	107
functionality.....	16
grounding.....	38
installation.....	35, 38
Modbus diagnostic codes.....	70
NTP configuration.....	14
rack extension.....	37
BMXCRA31210	
Control Expert configuration.....	47, 50, 53
description.....	14, 21
external features.....	17
firmware update.....	107
firmware upgrade.....	107
functionality.....	16
grounding.....	38
installation.....	35, 38
Modbus diagnostic codes.....	70
NTP configuration.....	14
rack extension.....	37
firmware upgrade.....	107
functionality.....	16
grounding.....	38
installation.....	35, 38
Modbus diagnostic codes.....	70
NTP configuration.....	14
rack extension.....	37
BMXCRA31210C	
description.....	14
BMXNGD0100	
global data.....	26
<b>C</b>	
CANopen modules	
X80.....	26
certifications.....	34
CIP objects.....	71
communication modules	
X80.....	26
connection manager object.....	75
<b>D</b>	
device DDT	
RIO adapters.....	58
T_M_CRA_EXT_IN.....	58
diagnostic module	
X80.....	29
diagnostics	
Modbus codes.....	70
system.....	68
<b>E</b>	
ethernet backplane diagnostics object.....	102
ethernet link object.....	81
Ethernet remote I/O	
Control Expert configuration.....	47
diagnostics.....	67
Ethernet RIO	
cabling.....	42
EtherNet/IP	
explicit messaging.....	64
implicit messaging.....	64
interface diagnostics object.....	85

EtherNet/IP explicit connection  
 diagnostics object ..... 90, 92  
 exchange  
 implicit I/O ..... 64

**F**  
 FAST task ..... 64  
 fiber cable converter modules  
 X80 ..... 26  
 firmware  
 update ..... 107  
 upgrade ..... 107

**G**  
 global data  
 BMXNGD0100 ..... 26  
 grounding ..... 38

**I**  
 identity object ..... 72  
 implicit I/O exchanges ..... 64  
 installation ..... 38  
 I/O  
 exchanges, implicit ..... 64  
 I/O connection diagnostics object ..... 87  
 I/O modules ..... 24

**M**  
 MAST task ..... 64  
 mounting a module ..... 40

**O**  
 online diagnostics ..... 105

**P**  
 PMESWT0100 ..... 29  
 PMXCDA0400 ..... 29  
 PMXNOW0300 ..... 29

**Q**  
 QoS object ..... 77

**R**  
 replacing module ..... 40  
 rotary switches ..... 41  
 RSTP diagnostics object ..... 94

**S**  
 setting rotary switches ..... 41  
 SNTP diagnostics object ..... 99  
 standards ..... 34

**T**  
 T\_M\_CRA\_EXT\_IN ..... 58  
 TCP/IP interface object ..... 79  
 time stamping ..... 56  
 BMXERT1604 module ..... 57  
 RIO drop adapters ..... 56  
 time stamping modules  
 X80 ..... 29

**U**  
 update  
 firmware ..... 107  
 upgrade  
 firmware ..... 107

**W**  
 weighing module  
 X80 ..... 29  
 wireless module  
 X80 ..... 29

**X**  
 X80  
 CANopen modules ..... 26  
 communication modules ..... 26

---

diagnostic module.....	29
fiber cable converter modules .....	26
time stamping modules .....	29
weighing module.....	29
wireless module.....	29
X80 I/O modules .....	24
analog .....	24
discrete.....	26
intelligent .....	29
special purpose .....	29

Schneider Electric  
35 rue Joseph Monier  
92500 Rueil Malmaison  
France

+ 33 (0) 1 41 29 70 00

[www.se.com](http://www.se.com)

As standards, specifications, and design change from time to time, please ask for confirmation of the information given in this publication.

© 2022 Schneider Electric. All rights reserved.

EIO0000001584.12