

Product Data Sheet

GW10341AB

CHORUSMART - Domestic range

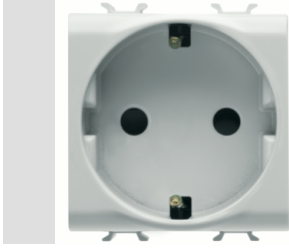

A range of ChoruSmart modular devices and plates made of antibacterial technopolymer in a glossy white finish, suitable for use in hospitals, nursing homes, schools and wherever cleanness and hygiene are essential. The effective silver-ion antibacterial treatment can reduce bacterial growth by 99% within 24 hours and has been verified by certified laboratory testing in accordance with standard ISO 22196 (analysis of major strains of Staphylococcus aureus and E. coli bacterial species).

Category	Dual amperage socket-outlet	Description	2P+E - 16A
Colour	Glossy white	Voltage	250 V ac
Standard	German	Characteristics	With safety shields
For plug pins	Ø 4.8 mm	Wiring terminals	Screws with front tightening terminals
Standard	IEC 60884-1; DIN VDE 0620-1; UNE 20315-1-1	Resistance at test voltage	2000 V at 50 Hz for 1 minute
Insulation resistance	> 5 MOhm	Prolonged operation socket (no.of position changes)	10.000 at In 250 V ac cosØ=0,8
Thermo-pressure with ball	125 °C	Glow Wire Test	850 °C
Terminal grip on cable traction	> 50 N	Terminal tightening capacity stranded cables (mm ²)	min. 0,75 - max. 2x4
Terminal tightening capacity solid cables (mm ²)	min. 0,5 - max. 2x2,5	No. modules	2
Electrocod	0131	Material	Antibacterial tecnopolymer

DIMENSIONAL

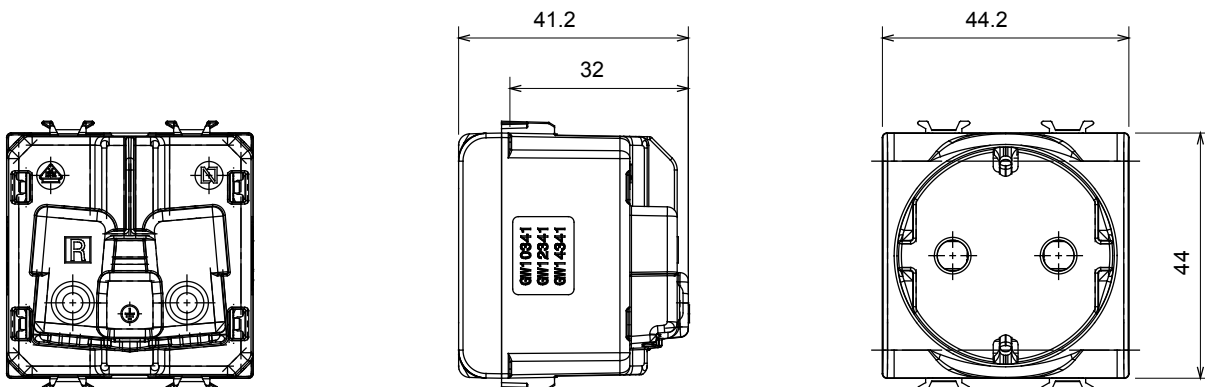

TECHNICAL SYMBOLOGY



STANDARDS/APPROVALS

