

Water Leak Detector 61F-WL

Set Sensitivity Freely to Suit the Liquid to Detect

- Sensitivity can be adjusted for an operating resistance of 0 to 50 kΩ
- Compact form allows space-saving design
- Free power supply makes design/inventory management easy
- Easy to replace during maintenance due to compatibility with the 61F-GPN-V50 series

 Refer to *Safety Precautions* on page 5.



For the most recent information on models that have been certified for safety standards, refer to your OMRON website.

Model Number Legend

61F - WL - CP □ - N R A
 (1) (2) (3) (4) (5) (6)

- | | | | | | |
|---|---|--|--------------------------------------|------------------------------|--|
| (1)Control Applications
WL: Water leak detector | (2)Structure
CP: Compact, plug-in | (3)No. of Pins
11: 11 pins
08: 8 pins | (4)Function
N: Normal type | (5)Output
R: Relay | (6)Supply Voltage
A: 100 - 240 VAC |
|---|---|--|--------------------------------------|------------------------------|--|

Ordering Information

Type	Model
Water leak detector	61F-WL-CP11-NRA
	61F-WL-CP08-NRA
Sensing Band	Refer to F03-16PE/-16PT/-15/-16PS/-16SF/-16SFC.
Sensing Band Protective Cover	

Accessories (Order Separately)

Connections Sockets

Connectable model	Type	Model
61F-WL-CP11-□	Front Connecting Type	PF113A
61F-WL-CP08-□		PF083A

Specifications

Ratings

	61F-WL-CP□-NRA
Supply voltage/frequency	100 VAC - 240 VAC 50/60 Hz
Operating voltage range	85% to 110% of rated voltage
Operating frequency range	±5 Hz of the rated frequency
Power consumption	3.2 VA max.
Contact ratings	3 A at 250 VAC (Resistive load ($\cos\phi = 1$)) 1 A at 250 VAC (Inductive load ($\cos\phi = 0.4$)) Minimum applicable load 5 VDC, 1 mA (reference value)
Ambient temperature	-10 to +55°C
Ambient humidity	25 to 85% RH
Ambient storage temperature	-10 to +55°C
Ambient storage humidity	25 to 85% RH
Weight	Approx. 100 g
Accessories	PFC-N8

Characteristics

	61F-WL-CP□-NRA
Operation resistance	Variable (0 to 50 kΩ)
Operation resistance error	Scale 0: 0 to 10 kΩ *1 Scale 50: 50 ±10 kΩ
Release resistance	Operation resistance + 50 kΩ or less
Interelectrode voltage	5 VAC
Response time	Operate: 80 ms max. Release: 160 ms max.
Startup lock time	3 s after turning on the power supply (The LED blinks during the startup lock time)
Insulation resistance *2	100 MΩ min. (at 500 VDC)
Dielectric strength *2	2000 VAC, 50/60 Hz for 1 min.
Life expectancy	Electrical: 100,000 operations min. Mechanical: 5,000,000 operations min.
Approved standards	UL61010-1, CAN/CSA C22.2 No.61010-1 CE, RCM EN61010-1, EN61326-1 Industrial electromagnetic environment

*1. The Detector may not operate around the setting value of "0".
Adjust the sensitivity depending on the actual application.

*2. The insulation resistance and dielectric strength indicate values between power terminals and Electrode terminals, between power terminals and contact terminals, and between Electrode terminals and contact terminals. Refer to *Safety Precautions* on page 5.

Nomenclature

61F-WL-CP□

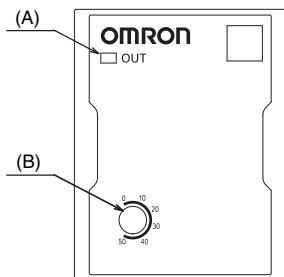

Symbol	Name	Function
(A)	[OUT] indicator (red)	Lit: Indicates that water has been detected. Unlit: Indicates standby state. Blinking: Indicates that power has turned on. (3 seconds when power is turned on)
(B)	Sensitivity adjustment volume	Sets operation resistance between 0 and 50 kΩ.

Connections

Water Leak Detector

61F-WL-CP08

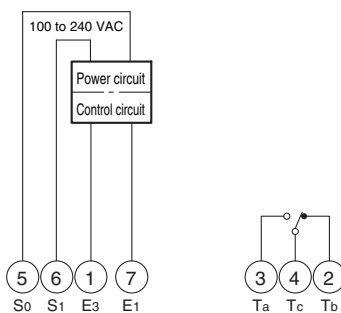

61F-WL-CP11

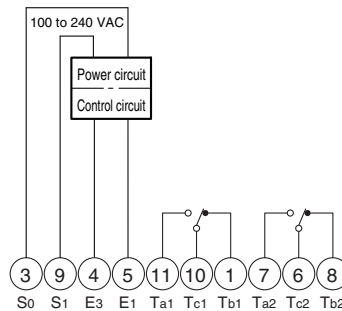

Operating Principle

When the two conductive cores of the Sensing Band are contacted by a liquid, a weak alternating current flows across the cores. This current is amplified to operate a relay. In practice, leakage will be detected if water drops are present between the core wire and the Electrode (F03-15 Sensing Band) or detecting section (F03-16PE Sensing Band).

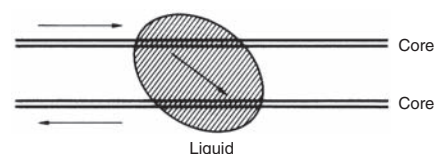

Dimensions

**Water Leak Detector
61F-WL-CP**

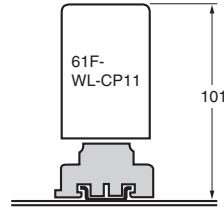
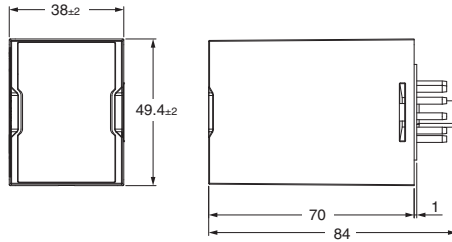

PF113A (Sold Separately)
PFC-N8 Mounting Bracket
(provided with 61F-WL)

Use a PFC-N8 Mounting Bracket to mount the Level Controller to a PF113A Rail-mounted Socket.

PFC-N8

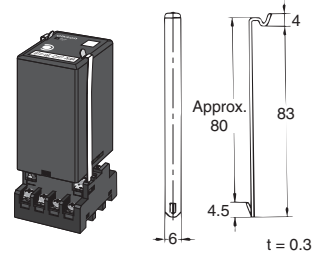

Note: PFC-N8 Mounting Bracket (provided with the Level Controller)

Use a PFC-N8 Mounting Bracket to mount the Level Controller to a PF083A Rail-mounted Socket.

PFC-N8

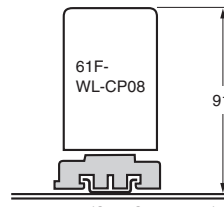
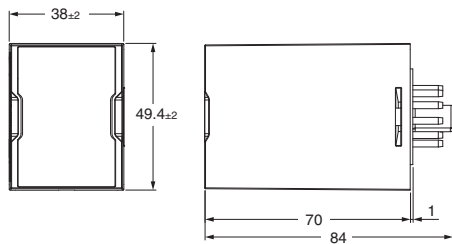

PF083A (Sold Separately)
PFC-N8 Mounting Bracket
(provided with 61F-WL)

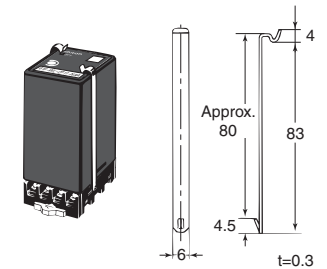

Note: PFC-N8 Mounting Bracket (provided with the Level Controller)

**Liquid Leakage Point Sensor
F03-16PS
F03-16PS-F**

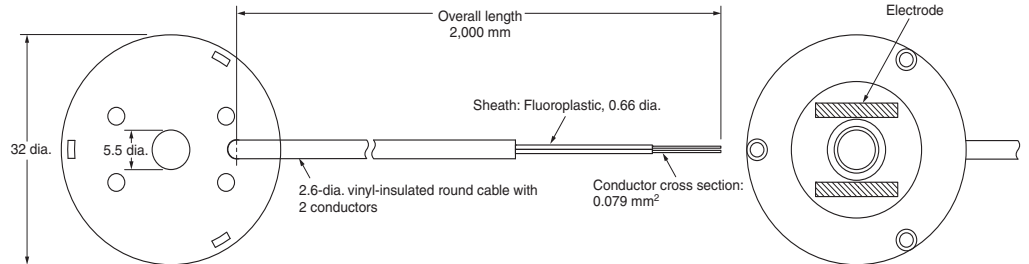
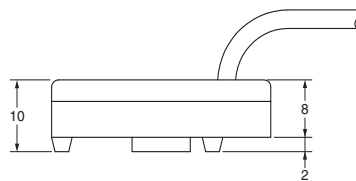

Note: Operation may not be possible with small amounts of liquid.

61F-WL

Point Sensor Mounting Bracket F03-26PS

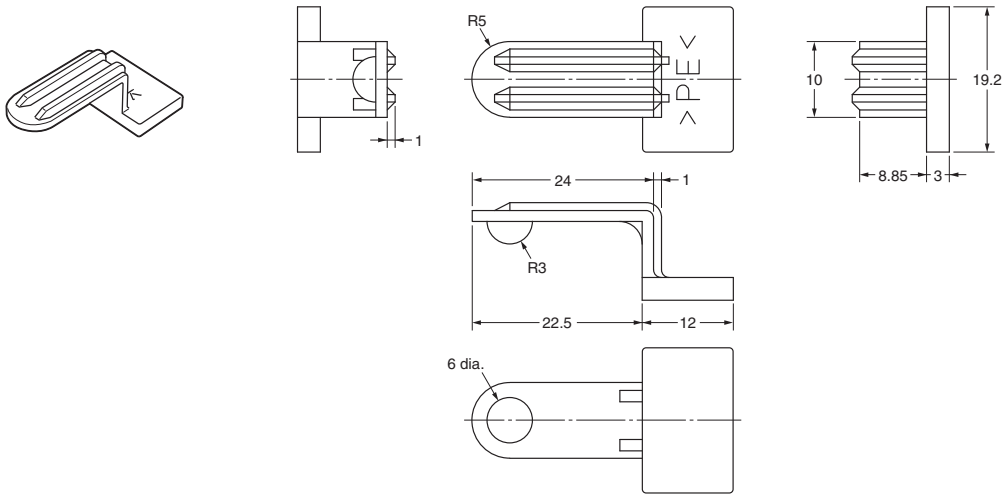

* Secure the Sockets with M3 screws at a torque of 0.78 to 1.18 N·m.

■ Replacement for the water leak detectors 61F-GPN-V50 and 61F-GP-N8-V50 is as follows.

Previous	New
61F-GPN-V50 AC□□V	61F-WL-CP11-NRA
61F-GP-N8-V50 AC□□V	61F-WL-CP08-NRA

Note: Take note that in case of 61F-WL-CP11-NRA or 61F-WL-CP08-NRA after turning on the power supply, there is a startup lock time of 1 to 3 seconds and the product cannot be operated during this time.





Safety Precautions

Be sure to read the precautions for all models in the website at the following URL: <http://www.ia.omron.com/>.

Meanings of the warning indications

 CAUTION	It may result in minor to moderate injury or property damage due to this risk if the product is not handled correctly.
Precautions for Safe Use	It indicates the actions that should be taken or avoided in order to use the product safely.
Precautions for Correct Use	It indicates the actions that should be taken or avoided to prevent product inoperability, malfunction, or adverse effects on its performance or functions.

Meanings of graphic symbols

	<p>● Caution on electric shock A notice that warns of the possibility of electric shock under certain conditions.</p>
	<p>● Prohibition symbol A general and non-specific notice of prohibition.</p>
	<p>● No disassembly A notice of prohibition where disassembly of the equipment may cause injury such as electric shock.</p>
	<p>● General forced action symbol A graphic symbol indicating the general action of an unspecified user.</p>

CAUTION

Minor injury may be caused by electric shock in rare cases. Turn off the power supply when wiring, and do not touch the terminals while the power is on. Do not touch the product with wet hands.



Slight electric shock, ignition, or equipment failure may occur in rare cases. Do not allow metal, wires, or chips from installation process to enter the product.



If the contact output is suddenly switched due to a failure in the product, physical damage to the facility, equipment, etc. connected to this product may occur in rare cases. Please be sure to conduct periodic inspections on this product.



Minor injury may be caused by explosion in rare cases. Do not use this product under presence of flammable or explosive gases.



Slight electric shock, ignition, or equipment failure may occur in rare cases. Do not disassemble, modify or repair this product, or touch its interior parts.



Precautions for Safe Use

Please be sure to thoroughly read and understand this manual before handling the product.

- Do not use or store this product under the following environments:
 - Any outdoor environment or one that comes under direct sunlight
 - Any environment where it may be splashed with water or oil
 - Any environment where it is exposed to the weather
 - Any environment where there is significant vibration and impact
 - Any environment where the temperature changes are drastic
 - Any environment where there is a risk of freezing or condensation
 - Any environment where there is dust or corrosive gas (especially sulfide gas, ammonia gas, etc.)
 - Any environment where it may be affected by static electricity or noise
 - Any environment where there are insects or small animals
 - Any environment where it may be splashed with flammable or soluble liquid
 - Any environment where it is exposed to sea breeze
- Install the product as far away as possible from equipment that generates strong high frequency or surge voltage.
- Do not place the product on an unstable surface. It poses a risk of the product falling and becoming damaged, or hitting someone and causing injury.
- Do not use the product if the product is dropped by mistake, as the inside of the product may be damaged.
- Install a switch or circuit breaker and provide an appropriate indication so that the operator can turn OFF the power immediately.
- Install the product in the correct orientation.
- Use the power supply voltage and load within the specifications and ratings.
- Use a power supply that will reach the rated voltage within 1second after the power is turned ON.
- Do not connect anything to unused terminals.
- This product should be handled by a specialist with knowledge about electricity.
- When using the equipment, make sure to check the wiring before turning on the power.
- It may be prone to radio disturbance. Do not use any radio wave receivers near the product.
- Use or store the product while keeping the ambient temperature and humidity within the specification range. In particular, do not install the product close to other heating equipment (equipment containing coil or winding). Implement forced cooling if necessary.
- It cannot be used for types of oil, etc. that have high specific resistance of liquid and conduct little electricity.
- Install the product while ensuring not to apply any load on the main body.
- Check that the output contacts are operating properly. Depending on the operating environment, deterioration of the internal relay may be accelerated and result in malfunction.
- Check that the indicator LED is operating properly. Depending on the operating environment, deterioration of the LED may be accelerated and result in indication failure.
- Use the setting volume within the following torque value range:

Rotation torque	Rotation stopping strength
20 mN·m	50 mN·m
- To prevent smoke generation and ignition, check the rating of the wires and use the wires that are listed below.

Type of wire	Wire material	Recommended wire diameter
Single wire/ stranded wire	Copper	0.25 to 2.0 mm ² AWG24 to AWG16
- To clean, use commercially available alcohol and no thinners.
- Dispose of this product as industrial waste.

Precautions for Correct Use

1. It cannot be used for flammable liquids such as gasoline, kerosene, and heavy oil.
2. When measuring the insulation resistance, never conduct megger tests between the electrode terminals.
3. This product requires a certain response time during operation and recovery. Employ caution regarding designs that require subtle timing for sequence control. For details, please check the product specifications for the model to be used.
4. As for the water leakage detection band, please use the electrode rod and the water leakage detection band that are used in 61F float-less switch, which our company manufactures.
Detection bands manufactured by our company: Model F03-15, Model F03-16PE, Model F03-16PT
5. If the distance from the water leakage detector main body to the water leakage detection band is long, use it by wiring the specified wire from the main body to the detection band.
Although this product is designed with sufficient consideration for noise resistance, install the water leakage detector main body and detection band as close to each other as possible to minimize the effect of noise, etc., and route the power supply and output at a distance if the location to be monitored is far away.

Model	Item	Specifications	Detection band
61F-WL-□		0 m *1	200 m at maximum
		10 m to 150 m *1	150 m at maximum
		200 m to 300 m *1	100 m at maximum
		350 m to 400 m *1	50 m at maximum

*1. For 2 mm²

6. Install the socket and DIN rail with screws to prevent loosening. If the screws are loose, vibration, impact, etc. may cause the DIN rail, socket, product main body, or wiring to come off.
7. When attaching a crimped terminal to a terminal screw, tighten it with the tightening torque within the range from 0.45 to 0.6 N·m.

Terms and Conditions Agreement

Read and understand this catalog.

Please read and understand this catalog before purchasing the products. Please consult your OMRON representative if you have any questions or comments.

Warranties.

(a) Exclusive Warranty. Omron's exclusive warranty is that the Products will be free from defects in materials and workmanship for a period of twelve months from the date of sale by Omron (or such other period expressed in writing by Omron). Omron disclaims all other warranties, express or implied.

(b) Limitations. OMRON MAKES NO WARRANTY OR REPRESENTATION, EXPRESS OR IMPLIED, ABOUT NON-INFRINGEMENT, MERCHANTABILITY OR FITNESS FOR A PARTICULAR PURPOSE OF THE PRODUCTS. BUYER ACKNOWLEDGES THAT IT ALONE HAS DETERMINED THAT THE PRODUCTS WILL SUITABLY MEET THE REQUIREMENTS OF THEIR INTENDED USE.

Omron further disclaims all warranties and responsibility of any type for claims or expenses based on infringement by the Products or otherwise of any intellectual property right. (c) Buyer Remedy. Omron's sole obligation hereunder shall be, at Omron's election, to (i) replace (in the form originally shipped with Buyer responsible for labor charges for removal or replacement thereof) the non-complying Product, (ii) repair the non-complying Product, or (iii) repay or credit Buyer an amount equal to the purchase price of the non-complying Product; provided that in no event shall Omron be responsible for warranty, repair, indemnity or any other claims or expenses regarding the Products unless Omron's analysis confirms that the Products were properly handled, stored, installed and maintained and not subject to contamination, abuse, misuse or inappropriate modification. Return of any Products by Buyer must be approved in writing by Omron before shipment. Omron Companies shall not be liable for the suitability or unsuitability or the results from the use of Products in combination with any electrical or electronic components, circuits, system assemblies or any other materials or substances or environments. Any advice, recommendations or information given orally or in writing, are not to be construed as an amendment or addition to the above warranty.

See <http://www.omron.com/global/> or contact your Omron representative for published information.

Limitation on Liability; Etc.

OMRON COMPANIES SHALL NOT BE LIABLE FOR SPECIAL, INDIRECT, INCIDENTAL, OR CONSEQUENTIAL DAMAGES, LOSS OF PROFITS OR PRODUCTION OR COMMERCIAL LOSS IN ANY WAY CONNECTED WITH THE PRODUCTS, WHETHER SUCH CLAIM IS BASED IN CONTRACT, WARRANTY, NEGLIGENCE OR STRICT LIABILITY.

Further, in no event shall liability of Omron Companies exceed the individual price of the Product on which liability is asserted.

Suitability of Use.

Omron Companies shall not be responsible for conformity with any standards, codes or regulations which apply to the combination of the Product in the Buyer's application or use of the Product. At Buyer's request, Omron will provide applicable third party certification documents identifying ratings and limitations of use which apply to the Product. This information by itself is not sufficient for a complete determination of the suitability of the Product in combination with the end product, machine, system, or other application or use. Buyer shall be solely responsible for determining appropriateness of the particular Product with respect to Buyer's application, product or system. Buyer shall take application responsibility in all cases.

NEVER USE THE PRODUCT FOR AN APPLICATION INVOLVING SERIOUS RISK TO LIFE OR PROPERTY OR IN LARGE QUANTITIES WITHOUT ENSURING THAT THE SYSTEM AS A WHOLE HAS BEEN DESIGNED TO ADDRESS THE RISKS, AND THAT THE OMRON PRODUCT(S) IS PROPERLY RATED AND INSTALLED FOR THE INTENDED USE WITHIN THE OVERALL EQUIPMENT OR SYSTEM.

Programmable Products.

Omron Companies shall not be responsible for the user's programming of a programmable Product, or any consequence thereof.

Performance Data.

Data presented in Omron Company websites, catalogs and other materials is provided as a guide for the user in determining suitability and does not constitute a warranty. It may represent the result of Omron's test conditions, and the user must correlate it to actual application requirements. Actual performance is subject to the Omron's Warranty and Limitations of Liability.

Change in Specifications.

Product specifications and accessories may be changed at any time based on improvements and other reasons. It is our practice to change part numbers when published ratings or features are changed, or when significant construction changes are made. However, some specifications of the Product may be changed without any notice. When in doubt, special part numbers may be assigned to fix or establish key specifications for your application. Please consult with your Omron's representative at any time to confirm actual specifications of purchased Product.

Errors and Omissions.

Information presented by Omron Companies has been checked and is believed to be accurate; however, no responsibility is assumed for clerical, typographical or proofreading errors or omissions.

Note: Do not use this document to operate the Unit.

OMRON Corporation Industrial Automation Company

Kyoto, JAPAN

Contact : www.ia.omron.com

Regional Headquarters

OMRON EUROPE B.V.

Wegalaan 67-69, 2132 JD Hoofddorp
The Netherlands
Tel: (31) 2356-81-300 Fax: (31) 2356-81-388

OMRON ELECTRONICS LLC

2895 Greenspoint Parkway, Suite 200
Hoffman Estates, IL 60169 U.S.A.
Tel: (1) 847-843-7900 Fax: (1) 847-843-7787

OMRON ASIA PACIFIC PTE. LTD.

438B Alexandra Road, #08-01/02 Alexandra
Technopark, Singapore 119968
Tel: (65) 6835-3011 Fax: (65) 6835-3011

OMRON (CHINA) CO., LTD.

Room 2211, Bank of China Tower,
200 Yin Cheng Zhong Road,
PuDong New Area, Shanghai, 200120, China
Tel: (86) 21-6023-0333 Fax: (86) 21-5037-2388

Authorized Distributor:

©OMRON Corporation 2022-2024 All Rights Reserved.
In the interest of product improvement,
specifications are subject to change without notice.

CSM_2_3

Cat. No. N232-E1-05 0324 (0322)