

Compact CANopen HMI Controller SCU System User Guide

03/2015



The information provided in this documentation contains general descriptions and/or technical characteristics of the performance of the products contained herein. This documentation is not intended as a substitute for and is not to be used for determining suitability or reliability of these products for specific user applications. It is the duty of any such user or integrator to perform the appropriate and complete risk analysis, evaluation and testing of the products with respect to the relevant specific application or use thereof. Neither Schneider Electric nor any of its affiliates or subsidiaries shall be responsible or liable for misuse of the information contained herein. If you have any suggestions for improvements or amendments or have found errors in this publication, please notify us.

No part of this document may be reproduced in any form or by any means, electronic or mechanical, including photocopying, without express written permission of Schneider Electric.

All pertinent state, regional, and local safety regulations must be observed when installing and using this product. For reasons of safety and to help ensure compliance with documented system data, only the manufacturer should perform repairs to components.

When devices are used for applications with technical safety requirements, the relevant instructions must be followed.

Failure to use Schneider Electric software or approved software with our hardware products may result in injury, harm, or improper operating results.

Failure to observe this information can result in injury or equipment damage.

© 2015 Schneider Electric. All rights reserved.

Table of Contents



	Safety Information	7
	About the Book	11
Chapter 1	General Information	17
	Introduction	18
	Deliverables	19
Chapter 2	System Architecture	21
	Architecture Related Safety Information	22
	System Architecture	24
Chapter 3	Safety & Safety Requirements	27
	Safety Evolution Structure for the System User Guides	28
	Evolution of Legal Framework	29
	Risk Assessment	32
	Functional Safety Standards	36
	Standard EN ISO 13849-1 Machinery Safety - Safety-Related Parts of Control System	37
	Standard EN/IEC 62061 Machinery Safety - Safety-Related Parts of Control System	45
	Selecting the Applicable Standard	52
	More Information Regarding Safety	53
	Functional Safety Measures Implemented in this Architecture	55
Chapter 4	Hardware	59
4.1	Electrical Distribution and Monitoring	60
	PowerPact H-Frame Circuit Breaker - Hardware	61
	Multi-9 C60 (UL 1077) Circuit Breaker - Hardware	63
	Multi-9 C60 (UL 489) Circuit Breaker - Hardware	65
	Phaseo Power Supply Universal - Hardware	66
	iEM31xx Energy Meter Series - Hardware	68
4.2	Safety Modules	72
	Preventa XPSAF Safety Module - Hardware	73
	Preventa Detection and Dialog - Hardware	75
4.3	HMI	76
	Harmony XB5S - Hardware	77
	Harmony Control and Signaling - Hardware	80

4.4	Controller	81
	Magelis SCU HMI - Hardware	82
	Modicon OTB - Hardware	89
	Modicon TM2 Modules - Hardware	92
4.5	Communication	95
	ConneXium Ethernet Switch (Unmanaged) - Hardware	95
4.6	Motor Control	97
	TeSys D Contactor - Hardware	98
	TeSys U LU2B Motor Starter- Hardware	100
	TeSys GV2 Motor Circuit Breakers - Hardware	104
	Altivar 32 Variable Speed Drive - Hardware	106
	Lexium 28 Servo Drive - Hardware	110
	Lexium 32i Servo Drive - Hardware	118
4.7	Detection	122
	OsiSense Industrial Sensors - Hardware	122
Chapter 5	Communication Topology and Wiring Guide	123
5.1	Introduction to System Communication	124
	Introduction	124
5.2	CANopen/CANmotion Network	125
	CANopen Network Topology	126
	CANopen Network Wiring	127
	Magelis SCU HMI - CANopen Wiring	132
	TeSys U Communication Module LULC08 - CANopen Wiring	133
	Altivar 32 Variable Speed Drive - CANopen Wiring	135
	Lexium 28 - CANopen Wiring	137
	Lexium 32i Servo Drive - CANopen Wiring	139
	Modicon OTB - CANopen Wiring	142
5.3	Ethernet Network	145
	Ethernet Network Topology	146
	Ethernet Wiring	147
	Magelis SCU HMI - Ethernet Wiring	149
5.4	Modbus Serial Line Network	150
	Modbus SL Network Topology	151
	Modbus SL Wiring	152
	Magelis SCU HMI - Modbus SL Wiring	153
	iEM31xx Energy Meter - Modbus SL Wiring	155

Chapter 6	Implementation	157
6.1	Software Requirements	158
	Software Requirements	158
6.2	Access the SoMachine Project Template	159
	Access the SoMachine Project Template	159
6.3	Project	160
	HMI Controller	161
	Devices	163
	Application	170
	Vijeo-Designer	172
Chapter 7	System Setup	173
7.1	Setup Controller and HMI	175
	Setup Controller and HMI	175
7.2	Setup Other Devices	177
	Network and Device Parameter Settings	178
	TeSys U Motor Starter - CANopen Setup	179
	Altivar 32 Variable Speed Drive - CANopen Setup	180
	Lexium 28 Servo Drive - CANopen Setup	183
	Lexium 32i Servo Drive - CANopen Setup	185
	iEM3150 Energy Meter - Modbus SL Setup	186
Chapter 8	Adapt TVDA Template	189
8.1	Adapt SoMachine Project Template	190
	Introduction	191
	Device Modules in General	192
	Device Modules Used in This Project Template	193
	Add Device Modules	194
	Remove Device Module	196
8.2	Adapt HMI Application	197
	Introduction	197
Chapter 9	Bill of Material (BOM)	199
	Bill of Material (BOM)	199
Glossary	205
Index	211

Safety Information



Important Information

NOTICE

Read these instructions carefully, and look at the equipment to become familiar with the device before trying to install, operate, or maintain it. The following special messages may appear throughout this documentation or on the equipment to warn of potential hazards or to call attention to information that clarifies or simplifies a procedure.



The addition of this symbol to a “Danger” or “Warning” safety label indicates that an electrical hazard exists which will result in personal injury if the instructions are not followed.



This is the safety alert symbol. It is used to alert you to potential personal injury hazards. Obey all safety messages that follow this symbol to avoid possible injury or death.

DANGER

DANGER indicates a hazardous situation which, if not avoided, **will result in** death or serious injury.

WARNING

WARNING indicates a hazardous situation which, if not avoided, **could result in** death or serious injury.

CAUTION

CAUTION indicates a hazardous situation which, if not avoided, **could result in** minor or moderate injury.

NOTICE

NOTICE is used to address practices not related to physical injury.

PLEASE NOTE

Electrical equipment should be installed, operated, serviced, and maintained only by qualified personnel. No responsibility is assumed by Schneider Electric for any consequences arising out of the use of this material.

A qualified person is one who has skills and knowledge related to the construction and operation of electrical equipment and its installation, and has received safety training to recognize and avoid the hazards involved.

BEFORE YOU BEGIN

Do not use this product on machinery lacking effective point-of-operation guarding. Lack of effective point-of-operation guarding on a machine can result in serious injury to the operator of that machine.

WARNING

UNGUARDED EQUIPMENT

- Do not use this software and related automation equipment on equipment which does not have point-of-operation protection.
- Do not reach into machinery during operation.

Failure to follow these instructions can result in death, serious injury, or equipment damage.

This automation equipment and related software is used to control a variety of industrial processes. The type or model of automation equipment suitable for each application will vary depending on factors such as the control function required, degree of protection required, production methods, unusual conditions, government regulations, etc. In some applications, more than one processor may be required, as when backup redundancy is needed.

Only you, the user, machine builder or system integrator can be aware of all the conditions and factors present during setup, operation, and maintenance of the machine and, therefore, can determine the automation equipment and the related safeties and interlocks which can be properly used. When selecting automation and control equipment and related software for a particular application, you should refer to the applicable local and national standards and regulations. The National Safety Council's Accident Prevention Manual (nationally recognized in the United States of America) also provides much useful information.

In some applications, such as packaging machinery, additional operator protection such as point-of-operation guarding must be provided. This is necessary if the operator's hands and other parts of the body are free to enter the pinch points or other hazardous areas and serious injury can occur. Software products alone cannot protect an operator from injury. For this reason the software cannot be substituted for or take the place of point-of-operation protection.

Ensure that appropriate safeties and mechanical/electrical interlocks related to point-of-operation protection have been installed and are operational before placing the equipment into service. All interlocks and safeties related to point-of-operation protection must be coordinated with the related automation equipment and software programming.

NOTE: Coordination of safeties and mechanical/electrical interlocks for point-of-operation protection is outside the scope of the Function Block Library, System User Guide, or other implementation referenced in this documentation.

START-UP AND TEST

Before using electrical control and automation equipment for regular operation after installation, the system should be given a start-up test by qualified personnel to verify correct operation of the equipment. It is important that arrangements for such a check be made and that enough time is allowed to perform complete and satisfactory testing.

CAUTION

EQUIPMENT OPERATION HAZARD

- Verify that all installation and set up procedures have been completed.
- Before operational tests are performed, remove all blocks or other temporary holding means used for shipment from all component devices.
- Remove tools, meters, and debris from equipment.

Failure to follow these instructions can result in injury or equipment damage.

Follow all start-up tests recommended in the equipment documentation. Store all equipment documentation for future references.

Software testing must be done in both simulated and real environments.

Verify that the completed system is free from all short circuits and temporary grounds that are not installed according to local regulations (according to the National Electrical Code in the U.S.A, for instance). If high-potential voltage testing is necessary, follow recommendations in equipment documentation to prevent accidental equipment damage.

Before energizing equipment:

- Remove tools, meters, and debris from equipment.
- Close the equipment enclosure door.
- Remove all temporary grounds from incoming power lines.
- Perform all start-up tests recommended by the manufacturer.

OPERATION AND ADJUSTMENTS

The following precautions are from the NEMA Standards Publication ICS 7.1-1995 (English version prevails):

- Regardless of the care exercised in the design and manufacture of equipment or in the selection and ratings of components, there are hazards that can be encountered if such equipment is improperly operated.
- It is sometimes possible to misadjust the equipment and thus produce unsatisfactory or unsafe operation. Always use the manufacturer's instructions as a guide for functional adjustments. Personnel who have access to these adjustments should be familiar with the equipment manufacturer's instructions and the machinery used with the electrical equipment.
- Only those operational adjustments actually required by the operator should be accessible to the operator. Access to other controls should be restricted to prevent unauthorized changes in operating characteristics.

About the Book



At a Glance

Document Scope

This document describes a generic architecture based on Magelis SCU HMI Controller.

This document is intended to provide a quick introduction to the described system.

It is not intended to replace any specific product documentation, nor any of your own design documentation. On the contrary, it offers additional information to the product documentation for installing, configuring, and implementing the system.

The architecture described in this document is not a specific product in the normal commercial sense. It describes an example of how Schneider Electric and third-party components may be integrated to fulfill an industrial application.

A detailed functional description or the specification for a specific user application is not part of this document. Nevertheless, the document outlines some typical applications where the system could be implemented.

Your specific application requirements may be different and will require additional and/or different components. In this case, you will have to adapt the information provided in this document to your particular needs. To do so, you will need to consult the specific product documentation of the components that you are substituting in this architecture.

Pay particular attention in conforming to any safety information, different electrical requirements, and normative standards that would apply to your adaptation.

There are some major components in the architecture described in this document that cannot be substituted without completely invalidating the architecture, descriptions, instructions, wiring diagrams, and compatibility between the various software and hardware components specified herein.

Be aware of the consequences of component substitution in the architecture described in this document as substitutions may impair the compatibility and interoperability of software and hardware.

Validity Note

This document has been updated with the release of SoMachine V4.1 SP1 Lexium 28 add-on.

Related Documents

Title of Documentation	Reference Number
PowerPact Multistandard, Catalogue	LVPEd212023EN
The essential guide for power supplies and transformers	DIA3ED2070412EN
Multi 9 System, Catalog	0860CT0201
Phaseo power supplies and transformers, Catalogue Pages	14082-EN
iEM3100 series / iEM3200 series, Energy Meters, User Manual	DOCA0005EN
Control and protection components	MKTED210011EN
Preventa, Machine Safety Products	MKTED208051EN
The essential guide: Preventa machine safety	DIA4ED2041204EN
ATV32 - Safety integrated functions manual	S1A45606
Control and signaling components	MKTED208031EN
Magelis SCU HMI Controller, Hardware Manual	EIO0000001232
Magelis SCU, SoMachine, Programming Guide	EIO0000001240
Magelis SCU, SoMachine PLCSystem, Library Guide	EIO0000001246
ConneXium Ethernet Switches, TCSESU0••F•N0, Quick Reference Guide	31007950
Modicon TM2, Analog I/O Modules, Hardware Guide	EIO0000000034
Modicon TM2, Digital I/O Modules, Hardware Guide	EIO0000000028
Modicon TM2, High Speed Counter Modules, Hardware Guide	EIO0000000022
Advantys OTB CANopen, Remote Inputs and Outputs, User Manual	1606384
CANopen, Hardware Setup Manual	35010857
TeSys U, Starter-controllers, Catalogue	DIA1ED2081003EN
Altivar 32, Variable speed drives for synchronous and asynchronous motors, Installation manual	S1A28686 (ENG)
Altivar 32, Variable speed drives for synchronous and asynchronous motors, Programming manual	S1A28692 (ENG)
LXM32iCAN BMi, Lexium 32 Integrated, Product manual	0198441113950 (ENG)
LXM28A and BCH2, Servo drive system, Product manual	0198441114054-EN
LXM28 Library Function Blocks Software Manual	0198441114079 (ENG)
Electromechanical and solid-state relays, Zelio relay, Catalog	DIA5ED2120404EN
Detection for automation solutions OsiSense	MKTED210041EN
The essential guide of Detection	DIA4ED2041203EN
Transparent Ready, User Guide	31006929

Title of Documentation	Reference Number
Modbus Serial Line, Planning and Installation Guide	33003925
SoMachine Programming Guide	EIO0000000067 (ENG)

You can download these technical publications and other technical information from our website at www.schneider-electric.com.

Product Related Information

DANGER

HAZARD OF ELECTRIC SHOCK, EXPLOSION OR ARC FLASH

- Disconnect all power from all equipment including connected devices prior to removing any covers or doors, or installing or removing any accessories, hardware, cables, or wires except under the specific conditions specified in the appropriate hardware guide for this equipment.
- Always use a properly rated voltage sensing device to confirm the power is off where and when indicated.
- Replace and secure all covers, accessories, hardware, cables, and wires and confirm that a proper ground connection exists before applying power to the unit.
- Use only the specified voltage when operating this equipment and any associated products.

Failure to follow these instructions will result in death or serious injury.

Some of the equipment constituted by the architectures presented herein have been designed to operate outside of any hazardous location. Therefore, only install the equipment herein in zones known to be free of a hazardous atmosphere.

DANGER

POTENTIAL FOR EXPLOSION

Install and use this equipment in non-hazardous locations only.

Failure to follow these instructions will result in death or serious injury.

Consult the individual product documentation of the equipment described in the present document for specific safety information.

WARNING

LOSS OF CONTROL

- The designer of any control scheme must consider the potential failure modes of control paths and, for certain critical control functions, provide a means to achieve a safe state during and after a path failure. Examples of critical control functions are emergency stop and overtravel stop, power outage and restart.
- Separate or redundant control paths must be provided for critical control functions.
- System control paths may include communication links. Consideration must be given to the implications of unanticipated transmission delays or failures of the link.
- Observe all accident prevention regulations and local safety guidelines.¹
- Each implementation of this equipment must be individually and thoroughly tested for proper operation before being placed into service.

Failure to follow these instructions can result in death, serious injury, or equipment damage.

¹ For additional information, refer to NEMA ICS 1.1 (latest edition), "Safety Guidelines for the Application, Installation, and Maintenance of Solid State Control" and to NEMA ICS 7.1 (latest edition), "Safety Standards for Construction and Guide for Selection, Installation and Operation of Adjustable-Speed Drive Systems" or their equivalent governing your particular location.

WARNING

UNINTENDED EQUIPMENT OPERATION

- Only use software approved by Schneider Electric for use with this equipment.
- Update your application program every time you change the physical hardware configuration.

Failure to follow these instructions can result in death, serious injury, or equipment damage.

Applicable Terminology

The products described in the present document are designed to specific standards and the technical terms, terminology and the corresponding descriptions in this manual are intended to use the terms or definitions of those pertinent standards.

In the area of functional safety systems, drives and general automation, this may include, but is not limited to, terms such as "safety function", "safe state", "fault", "fault reset", "failure", "error", "error message", "dangerous", etc.

Among others, these standards include:

Standard	Description
EN 61131-2:2007	Programmable controllers, part 2: Equipment requirements and tests.
ISO 13849-1:2008	Safety of machinery: Safety related parts of control systems. General principles for design.
EN 61496-1:2013	Safety of machinery: Electro-sensitive protective equipment. Part 1: General requirements and tests.
IEC 61508-1:2010	Functional safety of electrical/electronic/programmable electronic safety-related systems: General requirements.
IEC 61508-2:2010	Functional safety of electrical/electronic/programmable electronic safety-related systems: Requirements for electrical/electronic/programmable electronic safety-related systems.
IEC 61508-3:2010	Functional safety of electrical/electronic/programmable electronic safety-related systems: Software requirements.
IEC 61784-3:2008	Digital data communication for measurement and control: Functional safety field buses.
IEC 62061:2005	Safety of machinery. Functional safety of safety-related electrical, electronic, and programmable electronic control systems
2006/42/EC	Machinery Directive
2004/108/EC	Electromagnetic Compatibility Directive
2006/95/EC	Low Voltage Directive

In addition, terms used in the present document may tangentially be used as they are derived from other standards such as:

Standard	Description
IEC 61800 series	Adjustable speed electrical power drive systems
IEC 61158 series	Digital data communications for measurement and control – Fieldbus for use in industrial control systems

Finally, the term "zone of operation" may be used in conjunction with the description of specific hazards, and is defined as it is for a "hazard zone" or "danger zone" in the EC Machinery Directive (EC/2006/42) and ISO 12100-1:2010.

Chapter 1

General Information

What Is in This Chapter?

This chapter contains the following topics:

Topic	Page
Introduction	18
Deliverables	19

Introduction

Overview

With **Tested Validated Documented Architectures** (TVDAs), Schneider Electric provides complete controlling system proposals applicable for a wide range of applications.

TVDAs are meant to help you to

- quickly find cost efficient controlling solutions,
- optimize the system implementation time,
- gain a competitive advantage and optimize overall costs for your machine.

With detailed component lists, wiring diagrams, commissioning guides, controller, and HMI applications the effort to assemble and setup the system becomes significantly reduced.

For a high level of reliability and robustness each TVDA is subjected to extensive system validation. Specific performance requirements as well as installation constraints are considered in the system design.

TVDAs provide a high level of openness for adaptations. With a clear separated project template structure and dedicated functions embedded in SoMachine and SoMachine Basic, required modifications can be realized quickly.

WARNING

UNINTENDED EQUIPMENT OPERATION

Thoroughly read and understand any and all device manuals for the characteristics and properties of the devices employed before attempting to modify parameters that may alter those characteristics and properties.

Failure to follow these instructions can result in death, serious injury, or equipment damage.

Deliverables

SoMachine Project Template

The SoMachine Project Template is comprised of a ready-to-use controller project covering the complete system configuration. Within the project template, you can find preconfigured application code to operate field devices, to monitor the system status, and to handle errors that are detected.

HMI Application

The HMI application is a ready-to-use interface that can:

- Control the main functionalities of the system
- Indicate the system status
- Visualize the system errors that are detected

System User Guide (SUG)

The System User Guide provides:

- System documentation with a focus on installation, commissioning, and adaptation of the system
- Bill of Material (BOM), including power distribution components
- Detailed installation information for each component
- Guidance on how to commission the complete system
- Introduction of available ranges and key features of each component used within the architecture
- Guidance on how to adapt the system efficiently by making use of dedicated functions provided within SoMachine software

Wiring Diagram

The wiring diagrams provide detailed guidance on the system wiring, and are reusable as a base to generate final technical documentation of the controlling system.

The wiring diagrams are provided for download on the Schneider Electric web page www.schneider-electric.com and are available in the following file formats:

- EPLAN Electric P8 V2.4 project archive
- *.pdf (generated with EPLAN)
- *.dwg (generated with EPLAN)

Chapter 2

System Architecture

What Is in This Chapter?

This chapter contains the following topics:

Topic	Page
Architecture Related Safety Information	22
System Architecture	24

Architecture Related Safety Information

Remote Devices

Remote control operating devices may lead to unintended equipment operation by:

- incorrect operation
- insufficient view on the machine during operation
- unintentional manipulation

The manufacturer or the operating company of the machine must take precautions to avoid unintentional equipment operation that may be caused by remote control.

WARNING

UNINTENDED EQUIPMENT OPERATION

- Place operator devices of the control system near the machine or in a place where you have full view of the machine.
- Protect operator commands against unauthorized access.
- If remote control is a necessary design aspect of the application, ensure that there is a local, competent, and qualified observer present when operating from a remote location.
- Configure and install the Run/Stop input for the application so that local control over the starting or stopping of the controller can be maintained regardless of the remote commands sent to any controller.

Failure to follow these instructions can result in death, serious injury, or equipment damage.

Wireless Devices

Data transmission between wireless devices can be influenced by environmental conditions. Especially for portable devices, such as wireless and batteryless push-buttons, the quality of the wireless communication is changing depending on the position of the device to the receiver.

WARNING

LOSS OF CONTROL

- Do not use wireless equipment as the only means of control for critical control functions such as motor start/stop or power disconnect.
- Provide separate or redundant control paths for critical control functions.
- Provide a means to achieve a safe state during and after a path failure for critical control functions such as emergency stop and overtravel stop.
- Improve the reliability of the wireless network by the use of repeater(s).

Failure to follow these instructions can result in death, serious injury, or equipment damage.

Communication

Fieldbuses or network communication may lead to loss of control by:

- Communication disturbance by external influences (for example wiring or EMC)
- Delay during communication
- Interruption of communication
- Inaccurate communication

WARNING

LOSS OF CONTROL

- The designer of any control scheme must consider the potential failure modes of control paths and, for certain critical control functions, provide a means to achieve a safe state during and after a path failure. Examples of critical control functions are emergency stop and overtravel stop, power outage and restart.
- Separate or redundant control paths must be provided for critical control functions.
- System control paths may include communication links. Consideration must be given to the implications of unanticipated transmission delays or failures of the link.
- Observe all accident prevention regulations and local safety guidelines.¹
- Each implementation of this equipment must be individually and thoroughly tested for proper operation before being placed into service.

Failure to follow these instructions can result in death, serious injury, or equipment damage.

¹ For additional information, refer to NEMA ICS 1.1 (latest edition), "Safety Guidelines for the Application, Installation, and Maintenance of Solid State Control" and to NEMA ICS 7.1 (latest edition), "Safety Standards for Construction and Guide for Selection, Installation and Operation of Adjustable-Speed Drive Systems" or their equivalent governing your particular location.

System Architecture

Overview

The architecture is arranged into the optimized performance class and is distinguished by the following characteristics:

- Magelis SCU small HMI controller for simple machines
- Energy metering
- CANopen fieldbus with 7 nodes
- Modbus serial line communication
- Application of machine safety
- 60 digital inputs (16 local and 44 distributed)
- 42 digital outputs (10 local and 32 distributed)
- 6 analog inputs (distributed)
- 1 analog output (distributed)
- Harmony XB5S biometric USB switch

The following devices are linked to the CANopen fieldbus and are controlled and monitored by the HMI controller:

- 6 coordinated drives:
 - 2 Altivar 32
 - 1 TeSys U
 - 2 Lexium 28
 - 1 Lexium 32i
- 1 Advantys OTB distributed I/O module

Layout

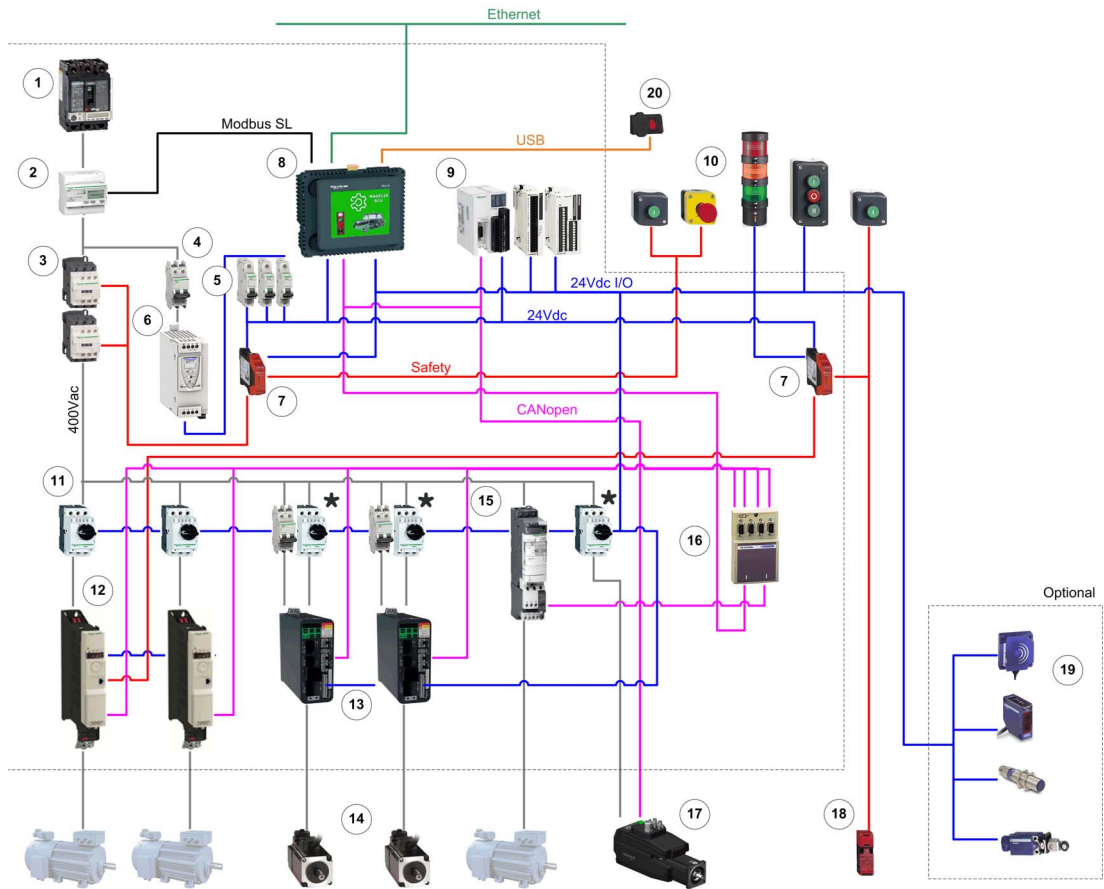

1	PowerPact H-Frame circuit breaker	11	TeSys GV2 motor circuit breaker
2	iEM3150 energy meter	12	Altivar 32 variable speed drive
3	TeSys D contactor	13	Lexium 28 servo drive
4	Multi 9 C60 (UL 489) circuit breaker	14	Lexium BCH2 servo motor
5	Multi 9 C60 (UL 1077) circuit breaker	15	TeSys U motor-starter controller
6	Phaseo power supply 24 Vdc	16	CANopen tap
7	Preventa XPS safety module	17	Lexium 32i servo drive
8	Magelis SCU HMI Controller	18	Preventa safety door guard

9	Advantys OTB distributed I/O island	19	OsiSense sensors and switches
10	Harmony signaling/control devices	20	Harmony XB5S biometric USB switch
*	<p>Conformance to standard UL 508C requires that fuses as per UL248 or circuit breakers as per UL489 are used for the branch circuit protection in place of the motor circuit breakers depicted above in front of the Lexium servo drives.</p> <p>For more information, refer to</p> <ul style="list-style-type: none"> ● LXM28A and BCH2, Servo drive system, Product manual, 0198441114054-EN ● LXM32iCAN BMi, Lexium 32 Integrated, Product manual, 0198441113950 (ENG) 		

Chapter 3

Safety & Safety Requirements

What Is in This Chapter?

This chapter contains the following topics:

Topic	Page
Safety Evolution Structure for the System User Guides	28
Evolution of Legal Framework	29
Risk Assessment	32
Functional Safety Standards	36
Standard EN ISO 13849-1 Machinery Safety - Safety-Related Parts of Control System	37
Standard EN/IEC 62061 Machinery Safety - Safety-Related Parts of Control System	45
Selecting the Applicable Standard	52
More Information Regarding Safety	53
Functional Safety Measures Implemented in this Architecture	55

Safety Evolution Structure for the System User Guides

Overview

1. Evolution of legal framework (*see page 29*)
2. Risk assessment (*see page 32*)
3. Functional safety standards overview (*see page 36*)
4. Standard EN ISO 13849-1 machinery safety (*see page 37*)
5. Standard EN/IEC 62061 machinery safety (*see page 45*)
6. Selecting the applicable standard (*see page 52*)
7. Where to get more information regarding safety (*see page 53*)
 - a. Safety guide
 - b. Sistema
 - c. Sistema library
8. Concept used on specific TVDA

Evolution of Legal Framework

EC Directive

Legal instrument to harmonize the legislation of the European member states

- Defines the essential health and safety requirements (EHSRs).
- Transposed into national law (act, decree, order, regulations).

Standard

A standard is a technical specification approved by a recognized standardization body for repeated or continuous application, with which compliance is not compulsory.

Harmonized Standard

A standard becomes harmonized when published throughout the member states.

Presumption of Conformity

- When a product conforms to a harmonized European standard, the reference to which has been published in the official journal of the European Union for a specific directive, and which covers one or more of the essential safety requirements, the product is presumed to comply with those essential safety requirements of the directive.
- In many cases European standards (ENs) are technically similar to international (IEC or ISO) standards. However only European standards include a list of which EHSRs are covered, so only European standards can confer a presumption of conformity.

European Directives and Safety Standards

Link between some of the main safety standards and the European directives according with the sectors of activity.

Fundamental rights from EU	Free circulation (CE mark)	Workers Protection	Environment Protection
European Union Directive	Machinery 2006/42/EC	Use of Work Equipment 89/391/EC	Seveso II 2008/99/EC96/82/EC
Sector of Activity	Machine Builder	End User System Integrator	End User System Integrator
Safety Standards			
Generic Standard EN/IEC 61508	Harmonized Standards EN ISO 13849-1 EN/IEC 62061	EN ISO 13849-1 EN/IEC 62061 EN/IEC 61508	EN/IEC 61511

A list of such standards can be accessed at:

<http://www.newapproach.org/Directives/DirectiveList.asp>

A, B and C Standards

When a type C standard deviates from one or more provisions dealt with by a type A standard or by a type B standard, the type C standard takes precedence. EN ISO 12100 is type A standards.

European standards for the machinery safety form the following structure:

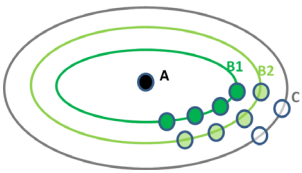
<p>Type A standards Basic safety standards giving basic concepts, principles for design, and general aspects that can be applied to all machinery.</p>	
<p>Type B standards Generic safety standards dealing with one safety aspect or one type of safeguard that can be used across a wide range of machinery:</p> <ul style="list-style-type: none"> ● Type B1 standards on particular safety aspects (for example, safety distances, surface temperature, noise) ● Type B2 standards on safeguards (for example, two-hand controls, interlocking devices, pressure sensitive devices, guards) 	
<p>Type C standards Machine safety standards dealing with detailed safety requirements for a particular machine or group of machines.</p>	

Some examples of these types of standards are:

Name	Type	Description
EN ISO 12100	A	2010 Safety of machinery - General principles for design - Risk assessment and risk reduction
EN ISO 13850	B	Emergency stop - Principles for design
EN/IEC 62061	B	Functional safety of safety-related electrical, electronic, and electronic programmable control systems
EN ISO 13849-1	B	Safety of machinery - safety-related parts of control systems - Part 1 general principles for design
EN 349	B	Minimum gaps to avoid crushing of parts of the human body
EN ISO 13857	B	Safety of machinery - safety distances to prevent hazard zones being reached by upper and lower limbs
EN 60204-1	B	Safety of machinery - Electrical equipment of machines - Part 1: General requirements
EN 1088/ISO 14119	B	Interlocking devices associated with guards - Principles for design and selection

Manufacturers' Responsibilities

Manufacturers placing machines on the market within the European Economic Area (EEA) must comply with the requirements of the machinery directive. Note that "placing on the market" includes an organization supplying a machine to itself, that is, building or modifying machines for its own use, or importing machines into the EEA.

Users' Responsibilities

Users of machines need to ensure that newly purchased machines are CE marked, and accompanied by a declaration of conformity to the machinery directive. Machines must be used in accordance with the manufacturer's instructions.

Existing machines taken into service before the machinery directive came into force do not need to comply, although they need to comply with the regulations resulting from the use of work equipment directive and be safe and fit for purpose.

Modification of machines can be considered as manufacture of a new machine, even if for use in-house, and the company modifying a machine needs to be aware that it might need to issue a declaration of conformity and CE marking.

Risk Assessment

European Legislation

Machines are sources of potential risk and the machinery directive requires a risk assessment to ensure that any potential risk is reduced to less than the acceptable risk.

Standard EN/ISO 12100 defines risk as follows: risk is the severity multiplied by the possibility of occurrence. It defines an iterative process for achieving machine safety, which states that the risks for each potential hazard can be determined in 4 stages.

1. Risk assessment
2. Determination of machine limits
3. Identification of the potential hazard
4. Risk evaluation

This method provides the basis for the requisite risk reduction.

Risk Assessment

Risk assessment consists of a series of logic steps which make it possible to analyze and evaluate machinery-related risks systematically.

Risk assessment is followed, whenever necessary, by a reduction of the risk.

This definition taken from standard EN/ISO 12100 is based on an iterative process represented in the diagram opposite.

Definition of risk

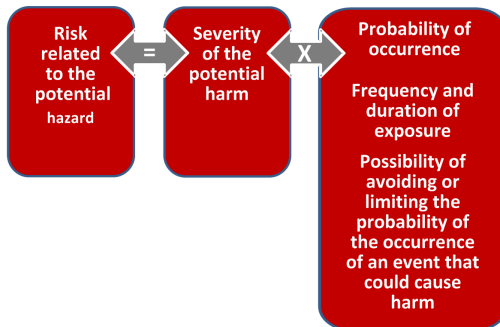

Determination of Machine Limits

Risk assessment starts by determining the limits of the machine at all stages of its life cycle:

- Transport, assembly, installation
- Commissioning
- Use
- De-commissioning, dismantling

The use limitations must then be specified:

- Operating modes
- Level of training required
- Space limits (amplitude, movement...)
- Time limits (life cycle, frequency of maintenance...)

Logic steps for risk analysis

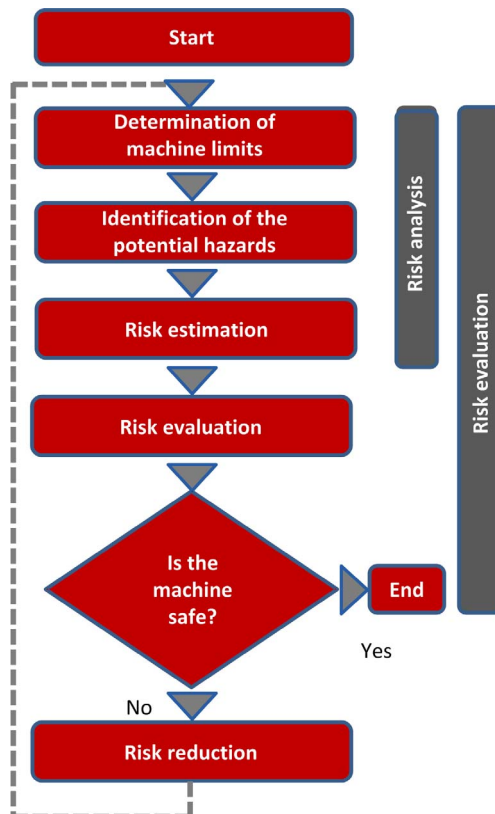

Identification of the Potential Hazard

If a potential hazard exists, a hazardous phenomenon will cause harm if measures are not taken. All the tasks associated with the life cycle of a machine must be identified, such as:

- Assembly, transport, and installation
- Adjustment, testing
- Learning, programming
- Tool changing
- Feeding, removal of product from the machine
- Starting, stopping
- Emergency stops, restarting after an unexpected stop
- Maintenance, cleaning, and so on.

The risk is a function of the severity of the harm and the probability that this harm will occur. The severity of the harm takes into account:

- The severity of injuries (slight, serious, death)
- The extent of the harm (number of persons)

The probability of the harm occurring takes into account:

- Exposure to the hazard (nature of access, time spent in the hazardous zone, number of persons exposed, frequency of access)
- The occurrence of a hazardous event (accident history, comparison of risks, ...)
- The possibility of avoiding or limiting the harm (experience, awareness of the risk, ...)

Elements of the risk

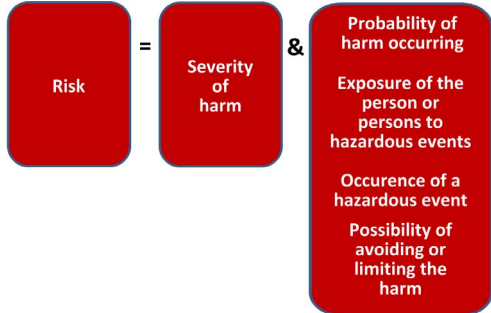

Risk Evaluation

Based on the risk assessment, the designer has to define the safety-related control system. To achieve that, the designer will choose one of the 2 standards appropriate to the application:

- either standard EN ISO 13849-1, which defines performance levels (PL)
- or standard EN/IEC 62061, which defines safety integrity level (SIL)

Risk Reduction

The process of risk reduction for dangerous events starts by:

- intrinsic prevention (inherently safe design)
- definition of the appropriate protective means (guards, carters, fix fences, ...)
- personnel training

If the selected preventive measure depends on a safety-related control system, the designer has to perform an iterative process for the design of the safety relative control system. The first stage is to define the necessary safety-related control functions:

- either through the choice of components
- or by adapting the control system architecture. Redundancy (double circuit components), for example, significantly increases the reliability of the solution

Once the limits of available technologies have been reached; it will not be possible to further reduce the rate of dangerous failures. To achieve the required level of safety, it will be necessary to use a diagnostic system that allows dangerous failures to be detected.

Functional Safety Standards

Overview

The functional safety standards are intended to encourage designers to focus more on the functions that are necessary to reduce each individual risk, and on the performance required for each function, rather than simply relying on particular components. These standards make it possible to achieve greater levels of safety throughout the life of a machine.

- Under the previous standard, EN 954-1, categories (B, 1, 2, 3 and 4) dictated how a safety-related electrical control circuit must behave under fault conditions. Designers can follow either EN ISO 13849-1 or EN/IEC 62061 to demonstrate conformity with the machinery directive. These 2 standards consider not only whether a fault will occur, but also how likely it is to occur.
- This means that there is a quantifiable, probabilistic element in compliance: machine builders must be able to determine whether their safety circuit meets the required safety integrity level (SIL) or performance level (PL). Panel builders and designers should be aware that manufacturers of the components used in safety circuits (such as safety detection components, safety logic solvers, and output devices like contactors) must provide detailed data on their products.

Standard EN ISO 13849-1 Machinery Safety - Safety-Related Parts of Control System

Overview

Standard EN ISO 13849-1 is an evolution of standard EN 954-1.

Field of Application of the Standard

This standard gives safety requirements and advice relating to principles for the design and integration of safety-related parts of control systems (SRP/CS), including software design.

For these parts, it specifies the characteristics, including the performance level, needed to achieve these safety functions. It applies to the SRP/CS of all types of machine, regardless of the technology and type of energy used (electric, hydraulic, pneumatic, mechanical, and so on).

Process

The risk assessment leads to decisions on risk reduction measures.

It defines a 6-stage design process:

1. Selection of the essential safety functions that SRP/CS must perform. For each safety function, specify the required characteristics.
2. Determine the required performance level (PLr).
3. Design and technical creation of safety functions: identify the parts that perform the safety function.
4. Evaluate the performance level PL for each safety-related part.
5. Check that the performance level PL achieved is greater than or equal to the required level (PLr).
6. Check that all requirements are satisfied.

The above 6 stages will be illustrated taking as an example a safety function where a severe injury can be caused by a horizontal movement on a machine not stopping where an operator maybe exposed to this dangerous situation. The machine is sometimes accessed by production workers and monitored during operation.

Stage 1 - Selection of Safety Functions

The diagram below shows a safety function which consists of several parts:

- The input actuated by opening of the guard (SRP/CSa)
- The control logic, limited in this example to opening or closing of a contactor coil (SRP/CSb)
- The power output that controls the motor (SRP/CSc)
- The connections (Iab, Ibc)

Representation of the safety function

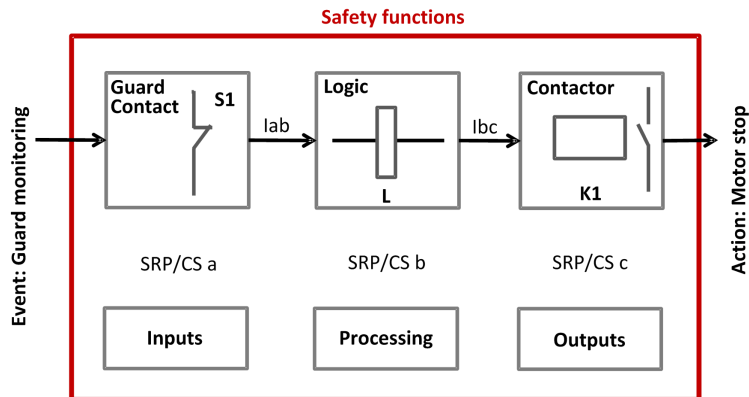

Stage 2 - Estimation of Required Performance Level (PLr)

Considering the example of the person coming into area where the machine is operating, the risk is estimated using the risk graph.

The parameters to be considered are:

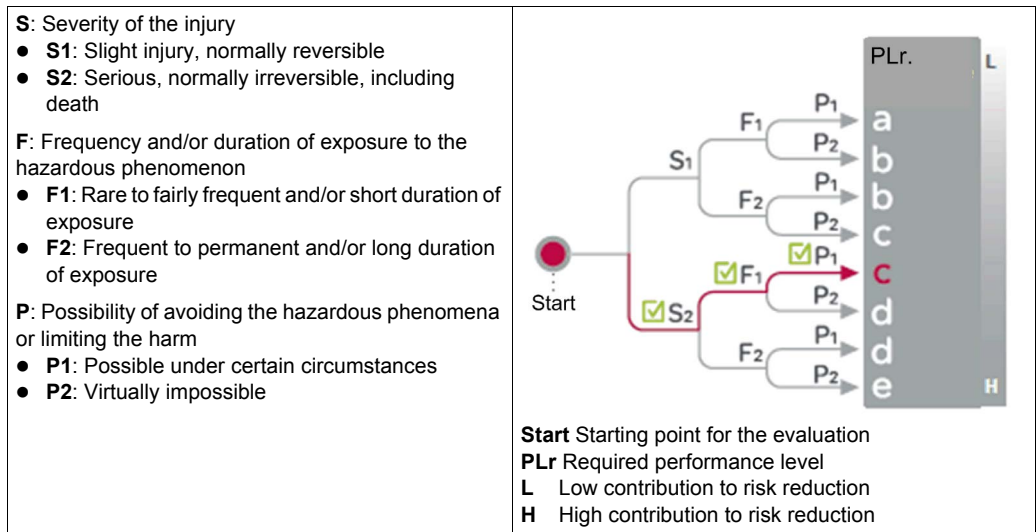

For the example: a serious injury **S2** can be caused by being exposed near the machine as if there is no safe guarding to ensure that the movement will stop the horizontal movement with a load may continue until collision.

After considering the severity of the injury investigate the frequency and/or duration of the possible entry to the dangerous area. Here you define the frequency of exposure to the hazard is low **F1** (occasional presence).

The last step is based upon the possibility to avoid the hazard and limiting the harm. To evaluate this, take into consideration that it is possible to avoid the harm as the visibility around the dangerous machine is monitored by the operator and in this case there is a possibility to avoid the harm under certain conditions so define it as **P1**.

The result of the estimation gives a required performance level **PLr = c**.

Stage 3 - Design and Creation of the Safety Functions

There is a need to describe the PL (performance level) calculation method.

For a SRP/CS (or a combination of SRP/CS), PL could be estimated with the figure after estimation of several factors such as:

- Hardware and software system structure (categories)
- Mechanism of failures, diagnostic coverage (DC)
- Components reliability, mean time to dangerous failure (MTTF_d)
- Common cause failure (CCF)

Categories (Cat.) and designated architectures

Summarized system behavior in the event of a failure and the principles used to achieve the safety, for the 5 categories defined.

Category	System Behavior	Designated Architecture
B	A fault can lead to loss of the safety function.	
1	As for category B but the probability of this occurrence is lower than for the category B.	
2	A fault can lead to loss of the safety function between 2 periodic inspections and loss of the safety function is detected by the control system at the next test.	
3	For a single fault, the safety function is always ensured. Only some faults will be detected. The accumulation of undetected faults can lead to loss of the safety function.	
4	When faults occur, the safety function is always ensured. Faults will be detected in time to prevent loss of the safety function.	
<p>Im Interconnecting means C Cross monitoring I, I1, I2 Input device, for example sensor L, L1, L2 Logic m Monitoring O, O1, O2 Output device, for example main contactor TE Test equipment OTE Output of TE</p>		

MTTF_d (mean time to dangerous failure)

The value of the MTTF_d of each channel is given in 3 levels (see table below) and shall be taken into account for each channel (for example, single channel, each channel of a redundant system) individually.

Reliability levels of components

Index	Range
Low	3 years \leq MTTF _d < 10 years
Medium	10 years \leq MTTF _d < 30 years
High	30 years \leq MTTF _d < 100 years

A MTTF_d of less than 3 years should never be found, because this would mean that after 1 year in operation, 30% of all those components in use would have failed to a dangerous state. The maximum value is limited to 100 years because devices dealing with a significant risk should not depend on the reliability of a single component. Additional measures such as redundancy and tests are required.

Diagnostic coverage (DC)

This term is expressed as a percentage and quantifies the ability to diagnose a dangerous failure.

For example, in the event of welding of a N/C contact in a relay, the state of the N/O contact could incorrectly indicate the opening of the circuit, unless the relay has mechanically linked N/O and N/C contacts, when the fault can be detected.

The standard recognizes 4 levels:

Denotation	Range
Nil	DC < 60%
Low	60% \leq DC < 90%
Medium	90% \leq DC < 99%
High	99% \leq DC

The relationship between categories, DC and MTTF_d of each channel and PL.

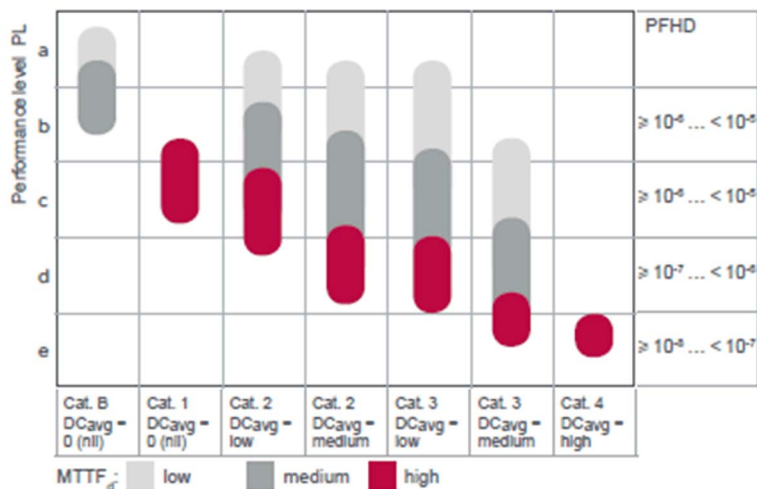

Using the above chart you can now select the most appropriate architecture, the required diagnostic coverage as well as ensure the products selected have the right MTTF_d values.

As the example requires PL=c the chart states as a minimum a category 1 architecture with a diagnostic coverage of 0 (Nil) and a MTTF_d of high is required.

It is possible to use architectures with higher categories to solve the safety function needs.

You start with determining the architecture required to solve the function. Use the following category 1 architecture:

Category	System Behavior	Designated Architecture
1	As for category B but the probability of this occurrence is lower than for the category B.	<pre> graph LR Event[Event] --> Input[Input] Input --> Processing[Processing] Processing --> Output[Output] Output --> Action[Action] </pre>

Knowing the architecture it is now possible to select the most appropriate products. Using the offer catalogs you define the products as illustrated below.

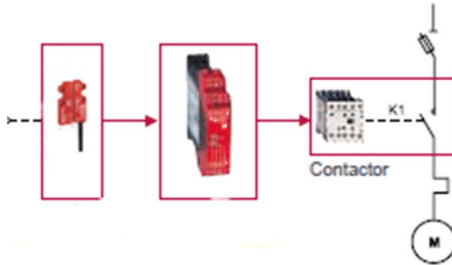

The selection of the right products may take several iterations as it is only possible to ensure that the right products are selected after calculations have been made.

Stage 4 - Evaluate the Performance Level (PL) for Each Safety-Related Part

Typically the data needed for the calculation of the performance level is being provided by the components supplier.

For safety processing devices the $MTTF_d$, DC and performance level values are provided.

For other non-safety components such as contactors, limit switches, and so on, which wear primary as a result of their mechanical actuation, B_{10d} values are provided by the supplier in some cases. When the B_{10d} values are not available, the annex C from the 13849-1 standard can be used.

Example	B_{10d} (Where 10% of the Population Fail to Dangerous Failure Mode)	$MTTF_d$	DC
SRP/CS _a : Magnetic switch	50000000	1578.28	-
SRP/CS _b : XPS AXE safety module	-	457	99.99%
SRP/CS _c : TeSys contactor	1369863	194	99%

To estimate the performance level of a safety function, the condition is that the $MTTF_d$, the DC, and the category from each component are known. The procedure to follow:

- Calculation of $MTTF_d$ and DC of the complete system
- Analysis of the category

For electromechanical products:

- The $MTTF_d$ is calculated based on the total number of operations that the product can perform, using B_{10d} values.

In this case, the machine operates for 220 days per year, 8 hours per day with a cycle of 90 s

- $N = 220 \times 8 \times (3600 / 90) = 70,400$ operations/year
- $MTTF_d = B_{10d} / (0.1 \times N)$

For the magnetic switch:

- The $MTTF_d = 1578$ years

For the contactors:

- The $MTTF_d = (1,369,863) / (0.1) \times 70,400 = 194$ years
- The $MTTF_d$ for each channel will then be calculated using the formula:

$$\frac{1}{MTTF_d} = \frac{1}{MTTF_{da}} + \frac{1}{MTTF_{db}} + \frac{1}{MTTF_{dc}}$$

that is, 284 years

A similar formula is used to calculate the diagnostic capability:

$$DC_{avg} = \frac{\frac{DC_a}{MTTF_{da}} + \frac{DC_b}{MTTF_{db}} + \frac{DC_c}{MTTF_{dc}}}{\frac{1}{MTTF_{da}} + \frac{1}{MTTF_{db}} + \frac{1}{MTTF_{dc}}}$$

The DC in the example is < 60%, for example nil.

Stage 5 - Checking That Required Performance Level Is Achieved

The result of the above calculations is summarized below:

- An architecture: category 1
- A mean time to failure > 30 years:
high $MTTF_d \gg$ a diagnostic capability < 60% (nil)

Looking at this table, confirms that PL level c is achieved:

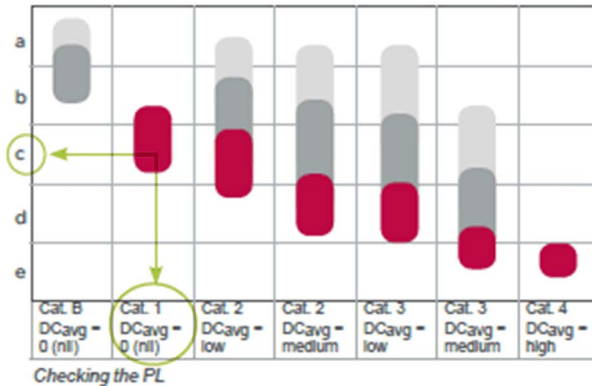

Stage 6 - Validation of the Required Performance Level

The design of SRP/CS must be validated and must show that the combination of SRP/CS performing each safety function satisfies all the applicable requirements of EN/ISO 13849.

Standard EN/IEC 62061 Machinery Safety - Safety-Related Parts of Control System

Overview

This standard is specific to the machine sector according to EN/IEC 61508. It gives rules for the integration of subsystems designed in accordance with EN/ISO 13849. It does not specify the operating requirements of non-electrical control components in machines (for example: hydraulic, pneumatic).

Functional Approach to Safety

As with EN/ISO 13849-1, the process using the EN/IEC 62061 starts with analysis of the risks (EN/ISO 12100) in order to be able to determine the safety requirements.

A particular feature of this standard is that it prompts you to make a functional analysis of the architecture; then split it into subfunctions and analyze their interactions before deciding on a hardware solution for them (the SRECS).

A functional safety plan must be drawn up and documented for each design project. It must include a specification of the safety requirements for the safety functions (SRCF) that is in 2 parts:

- Description of the functions and interfaces, operating modes, function priorities, frequency of operation, and so on.
- Specification of the safety integrity requirements for each function, expressed in terms of SIL (safety integrity level).

The structured and documented design process for safety-related electrical control systems (SRECS):

- The procedures and resources for recording and maintaining appropriate information.
- The process for management and modification of the configuration, taking into account organization and authorized personnel.
- The verification and validation plan

The decisive advantage of this approach is that of being able to offer a failure calculation method that incorporates all the parameters that can affect the reliability of electrical systems, whatever the technology used.

The method consists of assigning a SIL to each function, taking into account the following parameters:

1. The probability of a dangerous failure of the components (PFH_d)
2. The type of architecture; with or without redundancy, with or without diagnostic device making it possible to avoid some of the dangerous failures
3. Common cause failures (power cuts, overvoltage, loss of communication network, and so on) (CCF)
4. The probability of a dangerous transmission error where digital communication is used
5. Electromagnetic interference (EMC)

Process

Designing a system is split into 5 stages after having drawn up the functional safety plan:

1. Based on the safety requirements specification (SRS), assign a safety integrity level (SIL) and identify the basic structure of the safety-related electrical control system (SRECS), describe each related function (SRCF)
2. Break down each function into a function block structure (FB)
3. List the safety requirements for each function block and assign the function blocks to the subsystems within the architecture
4. Select the components for each subsystem
5. Design the diagnostic function and check that the specified safety integrity level (SIL) is achieved

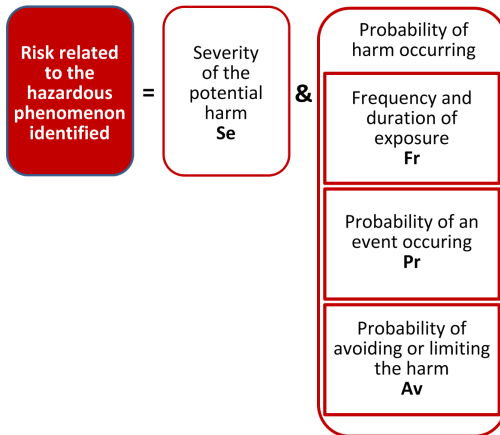

Stage 1 - Assign a Safety Integrity Level (SIL) and Identify the Structure of the SRECS

Based on the risk assessment performed in accordance with standard EN/ISO 12100, estimation of the required SIL is performed for each hazardous phenomenon and is broken down into parameters, see illustration below.

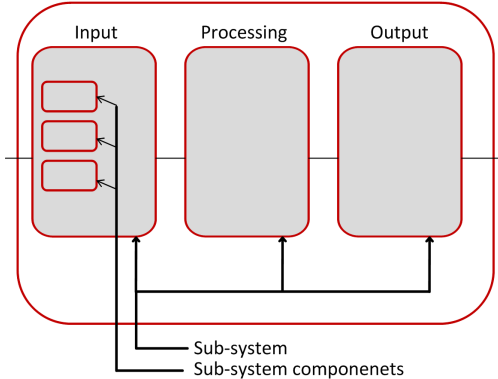

Severity Se

The severity of injuries or damage to health can be estimated by taking into account reversible injuries, irreversible injuries, and death.

Consequence	Severity Se
Irreversible: death, loss of an eye or an arm	4
Irreversible: shattered limb, loss of a finger	3
Reversible: requires the attention of a medical practitioner	2
Reversible: requires first aid	1

Probability of the harm occurring

Each of the 3 parameters Fr, Pr, Av must be estimated separately using the most unfavorable case. It is strongly recommended that a task analysis model is used in order to ensure that estimation of the probability of the harm occurring is correctly taken into account.

Frequency and duration of exposure Fr

The level of exposure is linked to the need to access the hazardous zone (normal operation, maintenance ...) and the type of access (manual feeding, adjustment...). It must then be possible to estimate the average frequency of exposure and its duration.

Frequency of Dangerous Exposure	Fr
≤1 hour	5
> 1 hour...≤1 day	4
>1 day=< 2 weeks	3

Frequency of Dangerous Exposure	Fr
2 weeks ≤1 year	2
> 1 year	1

Probability of occurrence of a hazardous event Pr

2 basic concepts must be taken into account:

- The predictability of the dangerous components in the various parts of the machine in its various operating modes (normal, maintenance, troubleshooting), paying particular attention to unexpected restarting
- The behavior of the persons interacting with the machine, such as stress, fatigue, inexperience, and so on.

Probability of Occurrence of a Dangerous Event	Pr
Very High	5
Probable	4
Possible	3
Almost impossible	2
Negligible	1

Probability of avoiding or limiting the harm Av

This parameter is linked to the design of the machine. It takes into account the suddenness of the occurrence of the hazardous event, the nature of the dangerous component (cutting, temperature, electrical) and the possibility for a person to identify a hazardous phenomenon.

Probability of Avoiding or Limiting the Harm	Av
Impossible	5
Almost impossible	3
Probable	1

Assignment of the SIL

Estimation is made with the help of the table below. In the example, the degree of severity is 4 because there is a risk of death; this value is shown in the first column of the table.

All the other parameters must be added together in order to select one of the classes (vertical columns in the table below), which gives:

- Fr = 5; access between 1 hour and a day
- Pr = 2; low probability of occurrence of the hazardous event (for example, operator monitoring)
- Av = 3; probability of avoiding almost impossible

Therefore a class CI = 5 + 2 + 3 = 10

A level of SIL 2 must be achieved by the safety-related electrical control systems (SRECS) on the machine.

Se	Class Cl				
	3-4	5-7	8-10	11-13	14-15
4	SIL 2	SIL 2	SIL 2	SIL 3	SIL 3
3	-	-	SIL 1	SIL 2	SIL 3
2	-	-	-	SIL 1	SIL 2
1	-	-	-	-	SIL 1

Basic structure of the SRECS

Without going into detail about the hardware components to be used, the system is broken down into subsystems. In the example, you find the 3 subsystems that will perform the input, processing, and output functions.

The figure below illustrates this stage, using the terminology given in the standard.

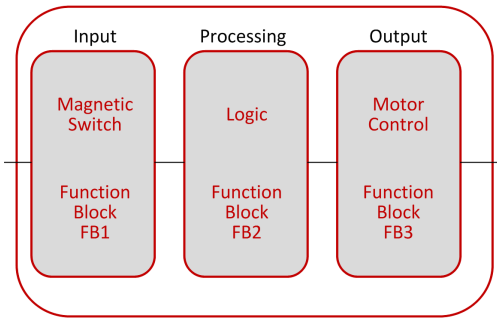

Stage 2 - Break down Each Function into a Function Block Structure (FB)

A function block (FB) is the result of a detailed breakdown of a safety-related function. The function block structure gives an initial concept of the SRECS architecture. The safety requirements of each block are deduced from the specification of the safety requirements of the system's function.

Stage 3 - List the Safety Requirements for Each Function Block and Assign the Function Blocks to the Subsystems

Each function block is assigned to a subsystem in the SRECS architecture. A failure of any subsystem will lead to the failure of the safety-related control function.

More than one function block may be assigned to each subsystem. Each subsystem may include subsystem elements and, if necessary, diagnostic functions in order to ensure that anomalies can be detected and the appropriate action taken.

These diagnostic functions (D) are considered as separate functions; they may be performed within the subsystem, by another internal or external subsystem.

Types of subsystem architectures

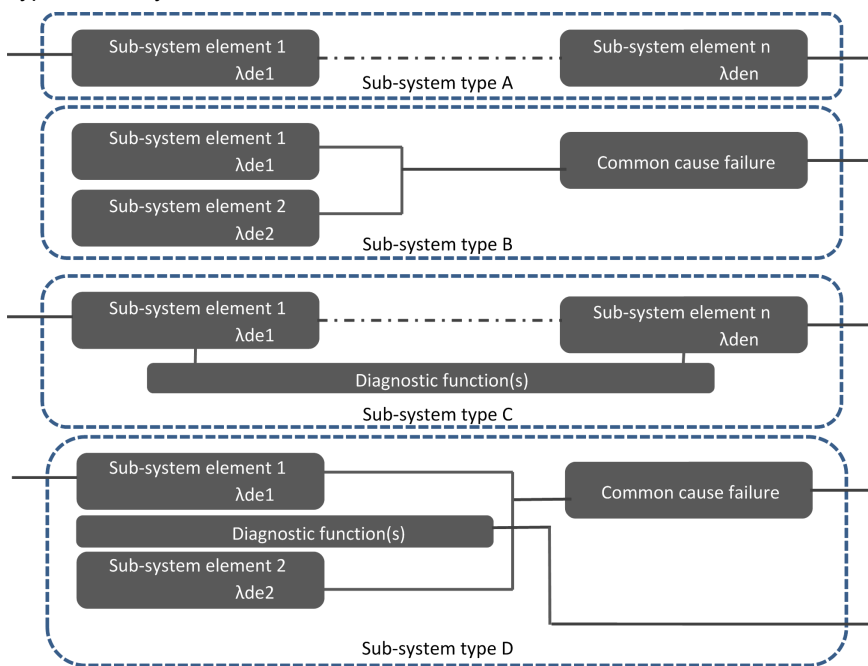

Stage 4 - Select the Components for Each Subsystem

As the safety integrity level required in the example mentioned above is SIL 2, each of the components must achieve this level. Once the targeted SIL is determined, the components constructing the system from safety-related subsystems (sensor/switch, logic, actuator) have to be selected. The components must have PFH_d (probability of dangerous failure per hour) equal to the required SIL rating needed.

Stage 5 - Design the Diagnostic Function

The SIL of the subsystem depends not only on the components, but also on the architecture selected. In EN 62061, a safety integrity requirement is expressed as a target failure value for the probability of dangerous failure per hour (PFH_d) of each safety-related control function (SRCF).

This can be calculated from reliability data for each component or subsystem, and is related to the SIL as shown in table 3 of the standard.

Relationship between SIL and PFH_d values

SIL	Probability of Dangerous Failures Per Hour (PFH _d)
3	$\geq 10^{-8} < 10^{-7}$
2	$\geq 10^{-7} < 10^{-6}$
1	$\geq 10^{-6} < 10^{-5}$

For each of the 4 logical architectures A to D presented above, there is a different formula to calculate the PFH_d. The calculation method is complex and will not be presented here (see EN/IEC 62061 for the formula and the parameters taken into account).

Selecting the Applicable Standard

Overview

In order to be able to select the applicable standard, a common table in both standards gives indications which are summarized below:

Technology Used	EN ISO 13849-1 Maximum PL	EN/IEC 62061 Maximum SIL
Non-electric only, for example, hydraulic	e	Not covered
Including some electromechanical, example: relays, and/or complex electronics	e (for designated architectures only)	3
Including complex electronics, for example programmable	D	3

Relationship between the performance level (PL) and the safety integrity level (SIL):

PL	SIL	Probability of Dangerous Failures Per Hour (1/h)
a	No correspondence	$\geq 10^{-5} < 10^{-4}$
b	1	$\geq 3 \times 10^{-6} < 10^{-5}$
c	1	$\geq 10^{-6} < 3 \times 10^{-6}$
d	2	$\geq 10^{-7} < 10^{-6}$
e	3	$\geq 10^{-8} < 10^{-7}$

More Information Regarding Safety

Overview

To know more about the relevant regulations, take a look to the safety guide:



<http://www.schneider-electric.com/download/ww/en/details/10101698-Machine-safety-guide/?reference=DIA4ED1100102EN>

Sistema

For support in creating the safety-related calculations in accordance to EN ISO 13849-1, refer to the free software as well as the related Schneider Electric Sistema offer library.

Sistema:

<http://www.dguv.de/bgja/en/prs/softwa/sistema/index.jsp>

Sistema library:

http://www2.schneider-electric.com/documents/original-equipment-manufacturers/SCHNEIDER-ELECTRIC-SAFETY-EN_2012_09.zip

Safety Chain Solutions

Schneider Electric offers a library of certified safety chain solutions.

Safety chain solutions provide you with a complete document explaining the concept, the used cases, the architecture, wiring diagram as well the complete calculation.

Each of the safety chain solutions is certified by TÜV enabling you to reuse the architectures for your machine and reusing the Sistema calculations as well as the documentation to help certify the machine to the European legislation.

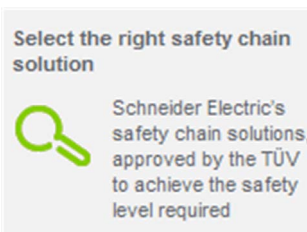

To find more information regarding the safety chain solutions:

<http://www2.schneider-electric.com/sites/corporate/en/solutions/oem/machine-safety/safety-selector.page>

Using the safety chain solutions provided by Schneider Electric to solve the existing architecture:

Step	Action	Comment
1	Perform a risk assessment of your machine.	A required performance level (PLr) must be specified for each intended safety function following a risk assessment in accordance to the standard EN ISO 12100.
2	Use the Safety Chain Selector * to find the most appropriated pre-certified architecture.	By answering the questions the most appropriated architectures will be proposed by the tool.
3	Adapt the proposed architecture to meet the needs of your machine risk assessment.	Select other devices to substitute those in the proposed architecture by examining the safety catalog.
4	Create the Systema file based on the used architecture within the Systema tool.	Each architecture, which is provided with the Safety Chain Selector is available as a template in the Systema tool.
5	Adapt the template in the Systema tool based on the adaptations to the architecture and/or substitution of devices done in step 3.	The safety library within the Systema tool contains numerous devices with all required parameters for the calculation.
6	Adapt the number of machine operations within the Systema file for your machine.	Within the template, default values were set and these have to be adapted in order to match the machine requirements.
7	Re-evaluate the achieved performance level.	Verify that the attained performance level by the control system is greater than or equal to the required performance level resulting from the risk assessment in step 1.
8	Document the relevant changes in the Systema file.	Specific information about the machine, the author, and so on, must be documented.
9	Print the Systema file to be used as part of the machine documentation.	It is necessary to provide the documentation about the risk assessment and the calculation of the machine.
* Safety Chain Selector: http://www2.schneider-electric.com/sites/corporate/en/solutions/oem/machine-safety/safety-selector.page		

Functional Safety Measures Implemented in this Architecture

Overview

Within the described architecture, there are 2 safety functions covering different risks. These will be described in the following sections.

NOTE: The safety functions proposed in this architecture do not provide a preferred safety chain solution for your machine. These are proposals as to how a safety function could be realized.

WARNING

UNINTENDED EQUIPMENT OPERATION

Ensure that a risk assessment is conducted and respected according to EN/ISO 12100 during the design of your machine.

Failure to follow these instructions can result in death, serious injury, or equipment damage.

Emergency Stop

In this TVDA, the safety function emergency stop is applied to disconnect the main power supply of all drives.

This safety architecture is conforming to category 4 EN ISO 13849-1:2008 and is using the stop category 0 in accordance with the standard IEC/EN 60204-1.

The architecture achieves a performance level (PL) of **e** and a safety integrity level (SIL) of **3**.

Used devices:



Device	Description
Input	2 channel emergency stop button Harmony XAL K
Logic	Preventa safety module XPSAF
Output	2 redundant contactors with feedback loop LC1D

Protective Door Monitoring

In this TVDA, the safety function protective door monitoring is applied to stop the motor driven by an Altivar 32. The uncontrolled stop of the motor is realized using the safety-related input STO (Safe Torque Off) of the Altivar 32.

The safety function STO (Safe Torque Off) only removes power to the motor. However, the drive itself remains under power. Further, the DC bus voltage is still present. If the door monitoring has been triggered because of, for example, the intention to do maintenance, you will need to remove main power even though power has been removed from the motor.

⚡ ⚠ **DANGER**

ELECTRIC SHOCK, EXPLOSION OR ARC FLASH

- Turn off the mains voltage using an appropriate switching device to remove power from the drive.
- After removing power, wait for 15 minutes to allow the DC bus capacitors to discharge in the drives.

Failure to follow these instructions will result in death or serious injury.

This safety architecture is conforming to category 3 EN ISO 13849-1:2008 and is using the stop category 0 in accordance with the standard IEC/EN 60204-1.

The architecture achieves a performance level (PL) of **d** and a safety integrity level (SIL) of **2**.

Used devices:



Device	Description	Comment
Input	2 channel guard switch Preventa XCS	-
Logic	Preventa safety module XPSAF	-
Output	Variable speed drive Altivar 32 with safety-related input	STO (Safe Torque Off) input of Altivar 32 to disconnect the power stage of the drive

NOTE: In this architecture the single channel input with safety function on the Altivar 32 is used. In order to reach a category 3 architecture, it is necessary to use a shielded cable for the wiring. The cable shield must be connected to the protective earth ground. Follow the wiring guidelines from the drive user manual.

The Altivar 32 drive incorporates additional safety-related functions which are not applied in this TVDA. For more information refer to ATV32 - Safety integrated functions manual, S1A45606.

Chapter 4

Hardware

Overview

This chapter provides general information about the hardware.

What Is in This Chapter?

This chapter contains the following sections:

Section	Topic	Page
4.1	Electrical Distribution and Monitoring	60
4.2	Safety Modules	72
4.3	HMI	76
4.4	Controller	81
4.5	Communication	95
4.6	Motor Control	97
4.7	Detection	122

Section 4.1

Electrical Distribution and Monitoring

What Is in This Section?

This section contains the following topics:

Topic	Page
PowerPact H-Frame Circuit Breaker - Hardware	61
Multi-9 C60 (UL 1077) Circuit Breaker - Hardware	63
Multi-9 C60 (UL 489) Circuit Breaker - Hardware	65
Phaseo Power Supply Universal - Hardware	66
iEM31xx Energy Meter Series - Hardware	68

PowerPact H-Frame Circuit Breaker - Hardware

Front View

PowerPact H-Frame circuit breaker (15...150 A)



Description

The PowerPact multistandard circuit breakers are designed to help protect electrical systems from damage caused by overloads and short circuits.

Multistandard circuit breakers are available with either thermal-magnetic or Micrologic electronic trip units. Multistandard circuit breakers with thermal-magnetic trip units contain individual thermal (overload) and immediate (short circuit) sensing elements in each pole.

PowerPact multistandard circuit breakers offer high performance and a wide range of interchangeable trip units to protect most applications. Electronic trip units provide highly accurate protection with wide setting ranges and can integrate measurement, metering, and communication functions. They can be combined with the front display module (FDM121) to provide functions similar to a power meter.

Industry-leading multistandard-compliant circuit breakers provide unrivalled reliability for heavy-duty applications. Common catalog numbers, standardized ratings, and a full range of field-installable accessories make product selection, installation, and maintenance easier than ever.

Features	<ul style="list-style-type: none"> ● Rated current 15...600 A ● Breaking capacity from 18...65 kA at 480 Vac ● 3-pole versions ● 3 frame sizes: PowerPact H (15...150 A), PowerPact J (150...250 A), and PowerPact L (250...600 A) ● Thermal-magnetic and electronic protection available for the entire range ● Common accessories and auxiliaries with Compact NSX range ● Suitable for isolation ● Switch-disconnector versions available ● Compliance with IEC 60947-2 and UL 489 ● Certifications: UL, CSA, CCC
Benefits	<ul style="list-style-type: none"> ● Multistandard compliant: IEC, UL, CSA, CCC ● Worldwide available with unique global part numbers ● Flexible and simple offer, with proven performance ● With direct access to energy metering and energy efficiency thanks to the Micrologic control units
Applications	<p>Feeder protection and circuit disconnect solutions when a multistandard approach for one global design machine is needed.</p> <ul style="list-style-type: none"> ● International & global multi-site OEMs applications ● Regional OEMs exporting to USA, with production in different countries, and in need of local support/maintenance.

For more information, refer to PowerPact Multistandard, Catalogue, LVPED212023EN.

Multi-9 C60 (UL 1077) Circuit Breaker - Hardware

Front View

Multi-9 C60 (UL 1077) miniature supplementary protectors



Description

The Multi-9 supplementary protector line from Schneider Electric is a modular system of supplementary protectors, accessories, and installation equipment that makes up the most complete product offering in its class.

These UL 1077 recognized supplementary protectors provide overcurrent protection in applications where branch circuit protection is either already provided or is not required.

- 0.5...63 A at 480Y/277 Vac
- Up to 10 k AIR
- 1-, 2-, 3-, and 4-pole versions
- Common tripping of all poles
- B-curve 3...5 in. (76.2...127 mm), C-curve 7...10 in. (177.8...254 mm), D-curve 10...14 in. (254...355.6 mm)
- Current limiting capability is standard
- Full line of accessories
- Only 0.71 in. (18 mm) width per pole
- Flush, surface, or DIN rail mountable
- UL 1077, IEC 60947-2, and CE marked

New accessories with UL ratings include the following:

- Comb bus bars - UL recognized comb bus bars for UL 1077 supplementary protectors simplify wiring. They are available in 1-, 2-, and 3-phase versions. They are fixed length of 12 poles and cannot be cut. (A wide variety of IEC rated comb bus bars is also available).
- Tooth caps for the unused teeth of the comb bus Bar are also available. They come in bags of 4 strips of 5 (for a total of 20 poles), but can be snapped apart to be used individually.
- Ring tongue terminal Kit: A field-installable kit provides isolation barriers and ring terminals to convert a standard box lug Multi-9 C60 (UL 1077) miniature supplementary protector.

For more information, refer to Multi 9 System, Catalog, 0860CT0201.

Multi-9 C60 (UL 489) Circuit Breaker - Hardware

Front View

Multi-9 C60 (UL 489) miniature circuit breakers



Description

The Multi-9 C60 (UL 489) miniature circuit breaker is a UL 489 version of the Schneider Electric Multi-9 C60 family of DIN rail mountable circuit protection devices.

UL 489 devices provide branch circuit protection while UL 1077 supplementary protectors do not.

Designed to meet global applications and code requirements, the UL listed Multi-9 breakers are the first product to carry UL 489, IEC 947-2, and CSA C22.2 ratings as well as the CE mark.

The Multi-9 breaker family features an extensive array of accessories.

- 1-, 2-, and 3-pole configurations
- 17 UL 489 ratings 0.5 A...35 A
- 2 trip curves available: C curve (7...10 times handle rating); D curve (10...14 times handle rating)
- Small size: less than 19.05 mm (0.75 in.) wide per pole
- Interrupting ratings 10K AIR standard
- System voltages include 120/240 Vac and 240 Vac; also DC ratings of 60 Vdc (1P) and 125 Vdc (2P)
- Ring terminals available (with finger-safe option)
- Padlock attachments for locking in the "OFF" position only
- Common tripping of all poles
- Variety of accessories including shunt trip, auxiliary switch, and under-voltage release. Same accessories can be used on both UL 1077 and UL 489 devices.
- Mounting base for 12...60 poles.

For more information, refer to Multi 9 System, Catalog, 0860CT0201.

Phaseo Power Supply Universal - Hardware

Front View

Phaseo ABL8RPS24100 power supply



Description

The Phaseo electronic switch mode power supply is designed to provide the DC voltage necessary for the controller and automation system equipment control circuits.

Conforming to IEC standards and UL, CSA, TÜV and C-Tick certified, they are suitable for industrial use.

The ABL8RPS/8WPS range of Phaseo power supplies covers power ratings 72...960 W in 24 Vdc and adapts to most power distribution systems used throughout the world. The same power supply can thus be connected phase to neutral or phase to phase for line supplies ranging 100...500 Vac nominal.

- Local or remote diagnostic functions
- Current limiting or stop in event of an overload
- Function modules to ensure continuity of service
- Power reserve for absorbing the transient current peaks

Standards and certifications	UL, CSA, TÜV, C-Tick
Power range	72...960 W
Voltage range	Input: 100...500 Vac Output: 24 Vdc
Degree of protection	IP 20 conforming to IEC 60529
Dimensions	6 different types (W x H x D): 44...165 x 143 x 120...155 mm (1.73...6.5 x 5.63 x 4.72...6.1 in.)

For more information, refer to :

- The essential guide for power supplies and transformers, DIA3ED2070412EN
- Phase0 power supplies and transformers, Catalogue Pages, 14082-EN

Wiring

Connection overview ABL8RPS24100

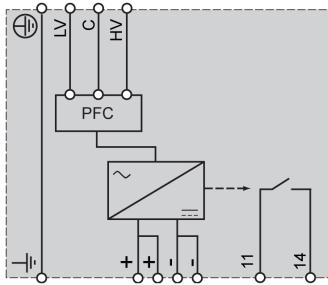

Wiring example: 200...500 V single phase

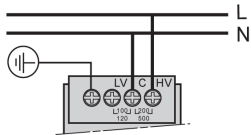

iEM31xx Energy Meter Series - Hardware

Front View

The graphic shows the front view of the energy meter iEM3110:



Description

The Acti 9 iEM3100 Energy Meter series offers a cost-attractive, competitive range of DIN rail-mounted energy meters ideal for subbilling and cost allocation applications. Combined with communication systems such as Smart Link, the Acti 9 iEM3100 series makes it easy to integrate electrical distribution measurements into your facility management systems. The Acti 9 iEM3100 series contains 8 versions of energy meter (for example, iEM3110 and iEM3150) to satisfy basic to advanced applications for buildings and industry, data centers, and networks, infrastructure, and so on.

- Graphical display for easy viewing
- Self-powered meters
- Direct measurement up to 63 A
- Onboard Modbus, LON, M-Bus or BACnet communication
- Commissioning safely with ease
- Compact size

Standards and certifications	IEC 61557-12, IEC 61036, IEC 61010, IEC 62053-21/22 class 1 and 0.5S, IEC 62053-23, EN50470-3
Current (max)	63 A
Models	iEM3100, iEM3110, iEM3115, iEM3135, iEM3150, iEM3155, iEM3165, iEM3175

Functions (depending on the model)	<ul style="list-style-type: none"> ● Active energy measurement ● Electrical measurements such as I, V, P, and so on. ● Alarm ● Digital output for pulse ● MID (legal metrology certification)
Degree of protection	<ul style="list-style-type: none"> ● front panel: IP40 ● casing: IP20
Dimensions	W x H x D: 90 x 95 x 69 mm (3.54 x 3.74 x 2.72 in.)

For more information, refer to iEM3100 series / iEM3200 series, Energy Meters, User Manual, DOCA0005EN.

Wiring

The graphic shows the wiring on three-phase systems for direct measurement of iEM31••

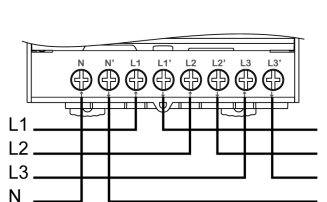

The graphic shows the connection diagram of iEM3100 / iEM3110 / iEM3115:

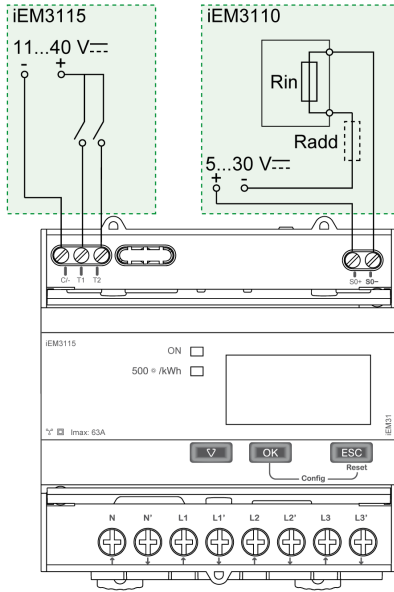

The figure shows the connection diagram of iEM3150 / iEM3155:

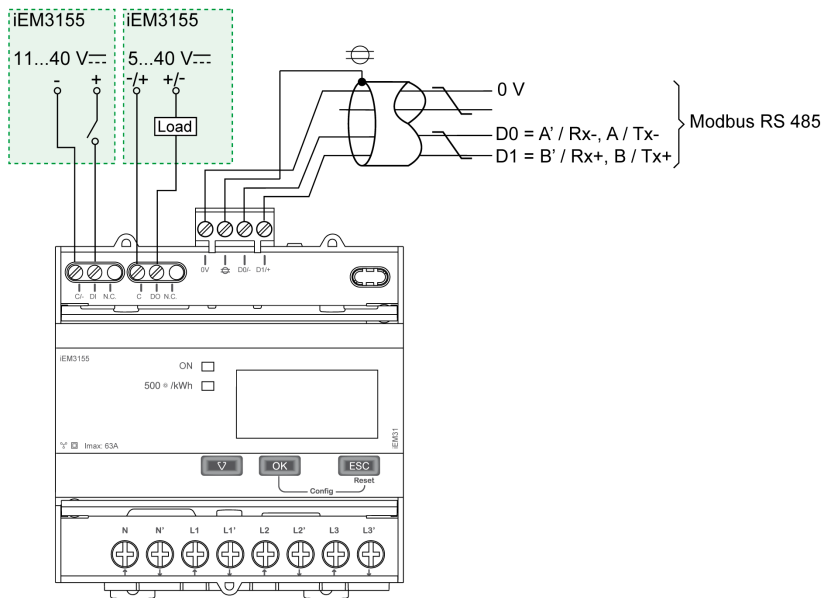

Section 4.2

Safety Modules

What Is in This Section?

This section contains the following topics:

Topic	Page
Preventa XPSAF Safety Module - Hardware	73
Preventa Detection and Dialog - Hardware	75

Preventa XPSAF Safety Module - Hardware

Front View

Preventa XPSAF safety module



Description

Safety module XPSAF is used for monitoring emergency stop circuits conforming to standards EN/ISO 13850 and EN 60204-1 and also meets the safety requirements for the electrical monitoring of switches on protection devices conforming to standard EN1088/ISO 14119.

- 3 LEDs which provide information on the monitoring circuit status
- Manual or automatic start
- 3 enabling paths, 1 signaling path
- Feedback loop to monitor external contactors

Maximum achievable safety integrity level	SILCL3 conforming to EN/IEC 62061, PL e/Category 4 conforming to EN/ISO 13849-1
Standards and certifications	EN 60204-1, Cat 4 EN954-1 ISO 13849-1, EN /ISO 14119, EN/ISO 13850, EN50082-2, EN/IEC 60947-5-1, UL, CSA, BG
Power supply	24 Vdc 24 Vac
Outputs	Relay immediate opening 3 NO, volt-free
Response time on input opening	< 40 ms
Degree of protection	Terminals: IP 20 Enclosure: IP 40
Dimensions	W x H x D: 22.5 x 99 x 114 mm (0.88 x 3.9 x 4.49 in.)
Options	Safety relay modules XPSECME and XPSECPE (for increasing the number of safety contacts)

For more information, refer to

- Preventa, Machine Safety Products, MKTED208051EN
- The essential guide: Preventa machine safety, DIA4ED2041204EN

Wiring

Wiring diagram for module XPSAF

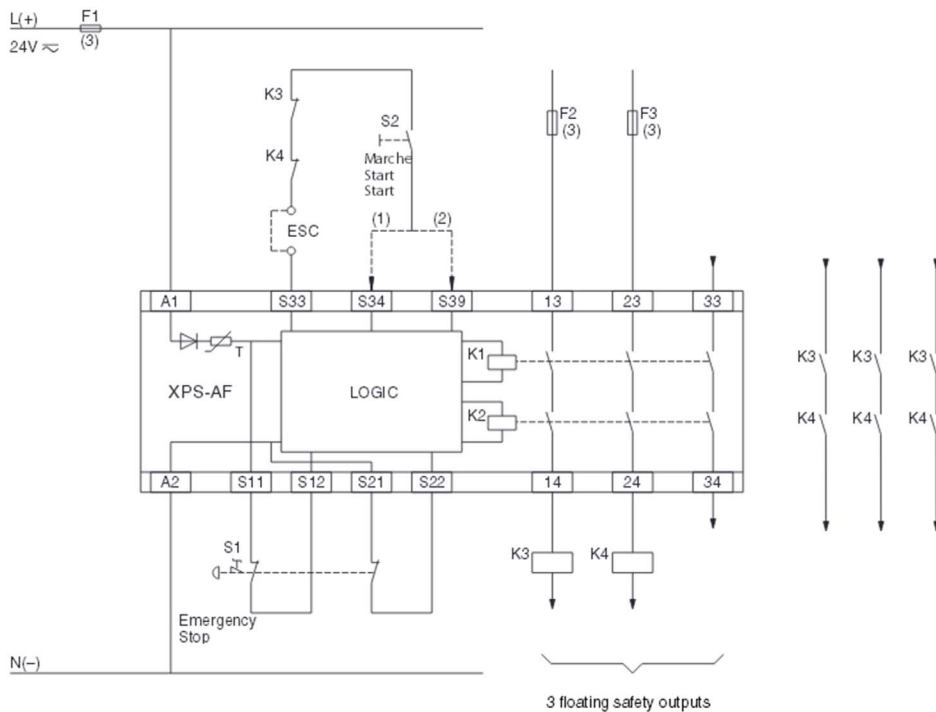

- (1) With monitoring of the start button
 - (2) Without monitoring of the start button
 - (3) See technical data for maximum fuse size
- ESC** External start conditions

Preventa Detection and Dialog - Hardware

Front View

Preventa product range



Description

The Preventa product range, offered under the Telemecanique Sensors brand, consists of safety detection products, safety dialog products, safety motor control products, safety automation products, and so on.

Preventa modules help to easily reach the required safety machinery and standards level in conformance with directives and standards.

The Preventa product range includes: Safety switches, limit switches, light curtains, emergency stop, foot switches, safety modules, and so on.

For more information, refer to

- Preventa solutions for efficient machine safety - catalogue, MKTED2140201EN
- The essential guide: Preventa machine safety, DIA4ED2041204EN

Section 4.3

HMI

What Is in This Section?

This section contains the following topics:

Topic	Page
Harmony XB5S - Hardware	77
Harmony Control and Signaling - Hardware	80

Harmony XB5S - Hardware

Front View

Front of the Harmony XB5S series



Description

Harmony XB5S is an innovative biometric switch that uses fingerprint authentication to control access to your machines, vehicles, and rooms. The database of authorized users can be managed directly on the device or externally via a PC or HMI interface. The USB switches communicate with the PC/HMI via the USB port.

The Harmony XB5S switch enables you to determine the level of access to different process areas and individual HMI menu tabs. It is designed for specific processes, servicing or setting-up processes, switching machine to maintenance mode, and resetting following activation of an emergency stop.

Harmony XB5S provides the following features:

- Reliable fingerprint recognition
- Security features: no password, no losing of key
- Extremely compact, standard \varnothing 22 mm (0.87 in.) cut-out
- Less than 1 second to authorize or refuse the access
- Less than 0.7 percent false acceptance rate

Standards and certifications	CSA C22-2 No. 14, UL508, IEC61000-6-2, IEC 61000-6-4UL, CSA, Gost, CE
Voltage range	24 Vdc

Types	<p>Stand alone biometric switches:</p> <ul style="list-style-type: none"> ● XB5S1 (bistable) and XB5S2 (monostable) ● configuration done directly on the biometric switch <p>Stand-alone USB biometric switches:</p> <ul style="list-style-type: none"> ● XB5S3 (bistable) and XB5S4 (monostable) ● configuration done with Harmony XB5S soft installed on a PC <p>USB biometric switches dedicated to Schneider Electric HMI:</p> <ul style="list-style-type: none"> ● XB5S5, connected permanently with HMI via USB ● configuration done with Vijeo-Designer and Harmony XB5Ssoft installed on a PC
Degree of protection	IP 65
Dimensions	W x H x D: 64 x 50 x 74 mm (2.52 x 1.97 x 2.91 in.)
Options	<ul style="list-style-type: none"> ● Translucent protective cover ● Mounting nut ● Legend plate ● USB extension cable

Physical Description

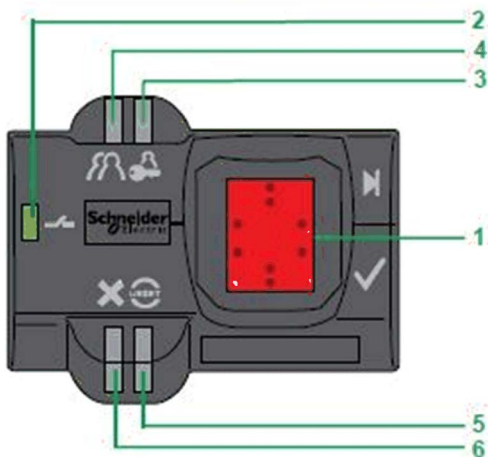

The stand-alone biometric switch (XB5S1/XB5S2) consists of a dark gray housing, with the following on its front face:

Item	Designation	Description
1	sensing screen	registration and subsequent recognition of the registered fingerprints
2	green LED	indicating output state, illuminates when the output is activated (solid-state NO contact)

Item	Designation	Description
3	orange LED	indicating administrator Registration mode
4	orange LED	indicating a user Registration mode
5	red RESET LED	indicating, in Delete mode, that the administrator is deleting all or part of the memory
6	red LED	flashing when the reader is presented with an unrecognized fingerprint or in the event of incorrect operation

Harmony Control and Signaling - Hardware

Front View

Harmony product range



Description

Schneider Electric offers a comprehensive range for control and signaling in industrial and commercial applications. All aspects of control and signaling needs are catered for including pilot devices such as push-buttons, indicator lamps, selector switches, and joysticks for standard hole cutouts.

For more information, refer to Control and signaling components, MKTED208031EN.

Section 4.4

Controller

What Is in This Section?

This section contains the following topics:

Topic	Page
Magelis SCU HMI - Hardware	82
Modicon OTB - Hardware	89
Modicon TM2 Modules - Hardware	92

Magelis SCU HMI - Hardware

Front View

Magelis SCU HMI

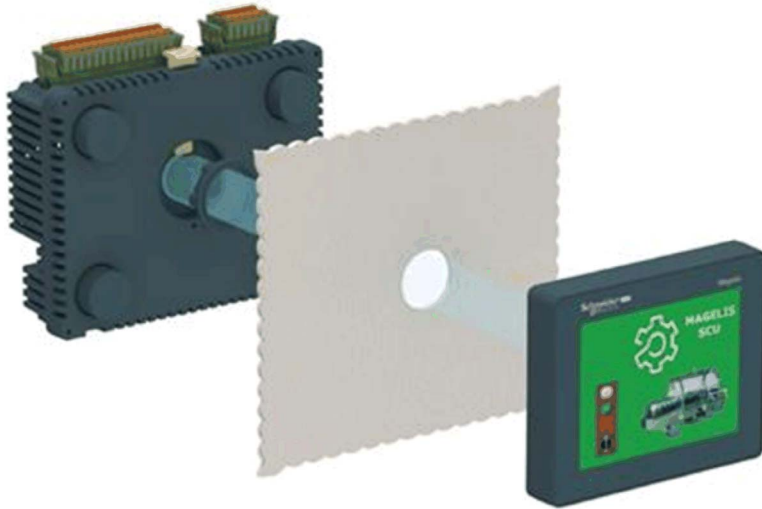

Description

The Magelis SCU is a modular HMI controller that delivers adequate functionality for control of small machines and simple processes, while saving up to 30% in installation and ownership costs throughout machine life cycle.

Especially suitable for packaging, HVAC, and pumping applications; its state-of-the-art display provides a crystal-clear readability. The Magelis SCU range consists of an HMI controller for machine control and an HMI controller for process control.

The HMI controller is part of the flexible control solution based on the SoMachine software, compliant with IEC 61123-3 and supporting 6 programming languages:

- IL: Instruction list
- LD: Ladder diagram
- ST: Structured text
- FBD: Function block diagram
- SFC: Sequential function chart
- CFC: Continuous function chart

Magelis SCU HMI Controller embeds all the key function in one modular solution without additional cost:

HMI controller provides the following operator dialog:

- LCD TFT 3.5" or 5.7" touchscreen for nice viewing and for accurate control

HMI controller supports the following communication functions:

- CANopen
- Ethernet
- Serial
- USB

HMI controller provides the following embedded I/Os:

- Digital I/Os including HSC, PTO/PWM
- analog I/Os, including temperature inputs*
*only provided by Magelis SCU type B controllers

Standard	WEE, directive 2002/96/EC;RoHS, directive 2011/65/EC;RoHS China, standard SJ/T 11363-2006;CE 2006/95/EC low voltage directive and 2004/108/EC EMC directive in compliance with IEC61131-2
Agencies	UL 508, CSA C22.2 No. 142
Rated voltage	24 Vdc
Voltage range	20.4...28.8 Vdc
Degree of protection	IP 20 with protective covers in place
Memory	128 Mb flash EPROM
Dimensions	W x H x D: <ul style="list-style-type: none"> ● 3.5" display: 128 x 102 x 74.95 +/- 0.5 mm (5.04 x 4.02 x 2.95 +/- 0.02 in.) ● 5.7" display: 163 x 129.4 x 76.22 +/- 0.5 mm. (6.42 x 5.09 x 3.0 +/-0.02 in.)
Options	Display module/rear module separation cable

For more information, refer to :

- Magelis SCU HMI Controller, Hardware Manual, EIO0000001232
- Magelis SCU, SoMachine, Programming Guide, EIO0000001240

Interfaces

Device	USB Printer Link	CAN	USB A	USB Mini B	Ethernet	Serial Line
HMISCU6A5 HMISCU8A5	1	1	1	1	1	1
HMISCU6B5 HMISCU8B5	1	1	1	1	1	1

Embedded I/Os

Device	Digital Inputs	Digital Relay Outputs	High Speed Counter	Pulse Train Transistor Outputs	Analog Inputs	Analog Outputs	Analog Temperature Inputs
HMISCU6A5 HMISCU8A	14	8	2	2	-	-	-
HMISCU6B5 HMISCU8B5	6	6	2	2	2	2	2

Physical Description

Rear module parts

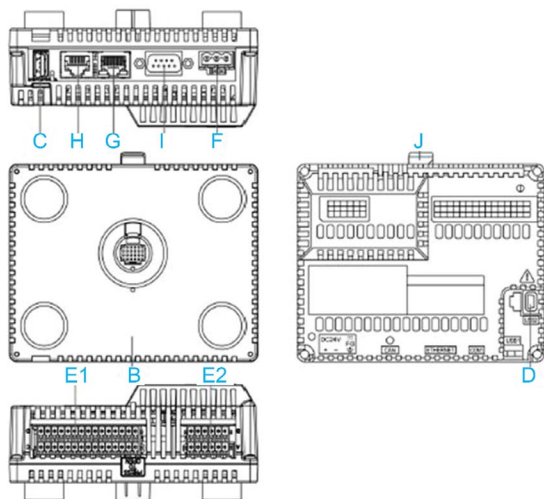

Part	Description
B	Rear module
C	USB (type A) port (USB1)
D	USB (type mini B) port (USB2)
E1	I/O terminal blocks C + D
E2	I/O terminal blocks A + B
F	DC power supply connector
G	Ethernet connector
H	Serial link (RS-232C/485)
I	CANopen connector
J	Yellow button lock

Wiring

Wiring example DC power supply

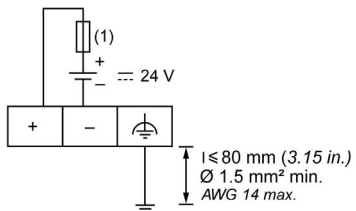

Wiring example digital inputs HMISCUxA5

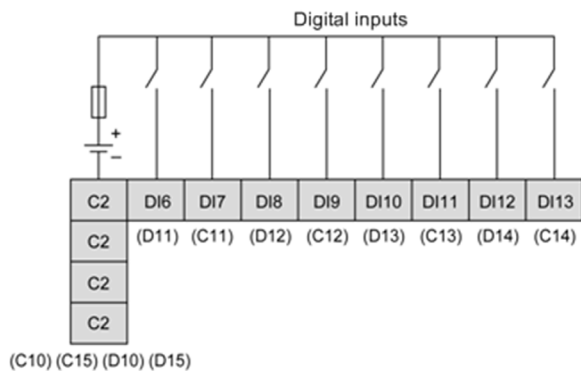
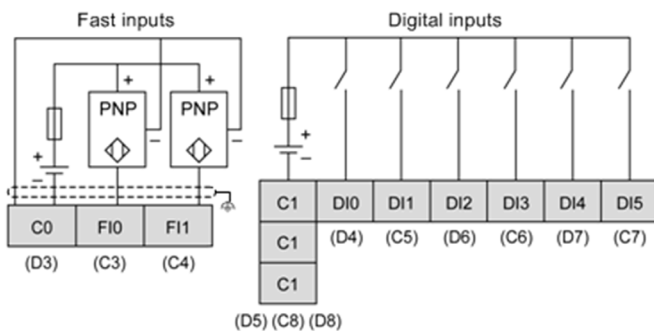

Wiring example digital outputs HMISCUxA5

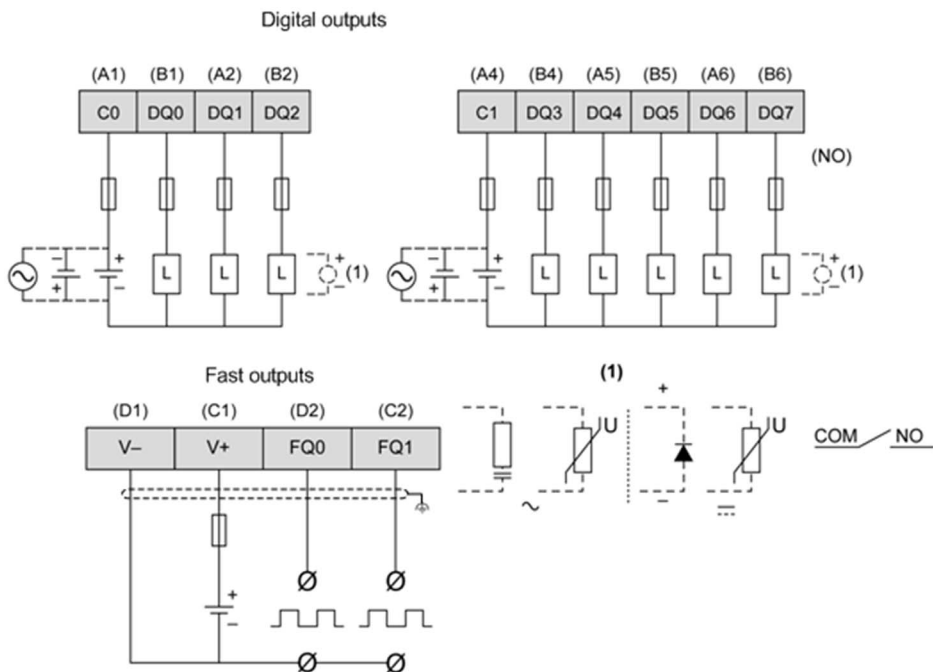

Wiring example digital inputs HMISCUxB5

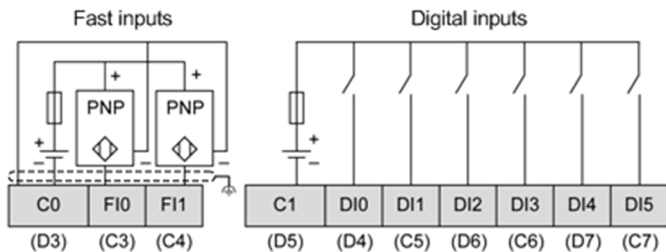

Wiring example digital outputs HMISCUxB5

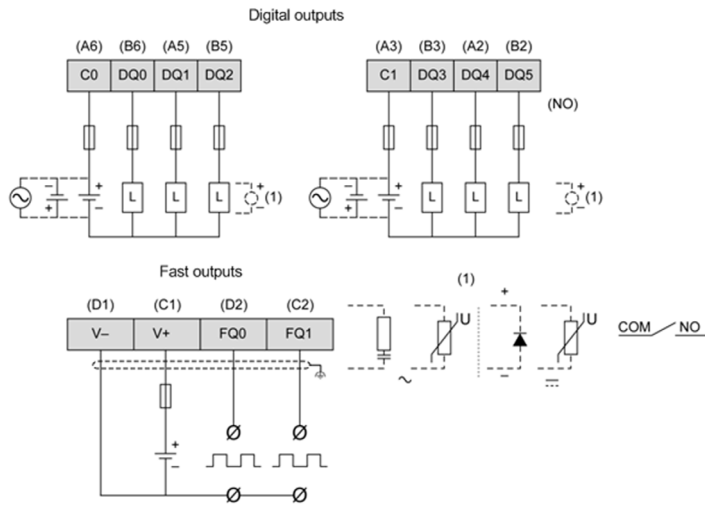

Wiring example analog inputs HMISCUxB5

Analog inputs

Voltage input

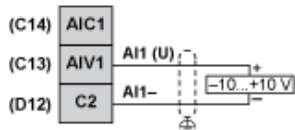
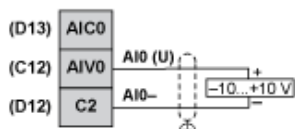

Current input

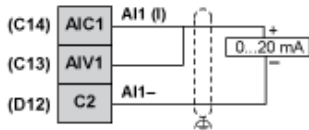
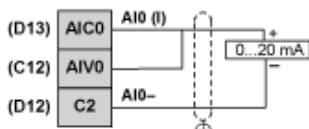

Analog outputs

Voltage and current outputs

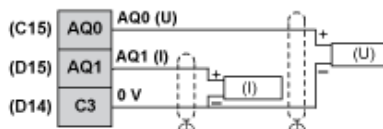

Analog inputs PT100

3-wiring

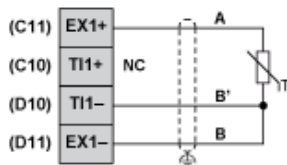
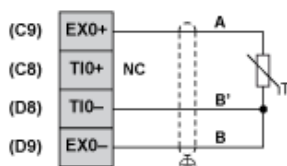

2-wiring

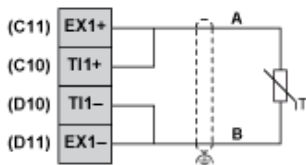
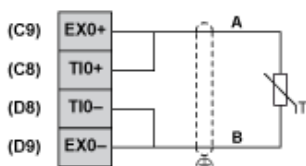

Thermocouple

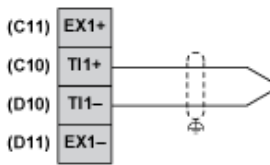
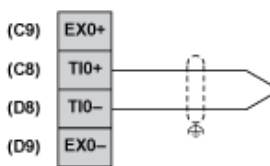

Modicon OTB - Hardware

Front View

Modicon OTB series



Description

Modicon OTB optimized distributed I/O allows the creation of I/O islands managed by a master controller via a fieldbus or communication network. With its expandable block type architecture, the Modicon OTB is ideally suited for small and medium size islands of distributed I/O that can be placed closer to the sensors and actuators they control, reducing wiring time and costs. The Modicon OTB solution includes 3 communication bases (interface modules) for the various types of fieldbus, CANopen, Modbus TCP/IP, or Modbus RS 485 serial line.

- Expandable with up to 7 TM2 expansion modules
- A wide range of I/O expansion modules
- Sensor/actuator connection using removable screw terminals
- Direct mounting on DIN rail
- Ideal compactness: 20 I/Os within a width of 55 mm (2.17 in.), including bus connection
- Reduces installation time and wiring costs

Standards and certifications	CSA, CSA C22.2 No. 213 (Class 1 division 2 groups A), CSA C22.2 No. 213 (Class 1 division 2 groups B), CSA C22.2 No. 213 (Class 1 division 2 groups C), CSA C22.2 No. 213 (Class 1 division 2 groups D), EN 61131-2, IEC 41131-2, UL508
power supply	24 Vdc
Degree of protection	IP20
Embedded I/Os	<ul style="list-style-type: none"> • 12 digital inputs • 8 digital outputs
Dimensions	W x H x D: 55 x 99 x 70 mm (2.17 x 3.9 x 2.76 in.)

For more information, refer to :

- Advantys OTB CANopen, Remote Inputs and Outputs, User Manual, 1606384
- Advantys OTB Ethernet, Remote Inputs/Outputs, User Manual, 1606385
- Modbus Advantys OTB, Remote Inputs/Outputs, User Manual, 1606383

Electrical Installation

Wiring example: power supply

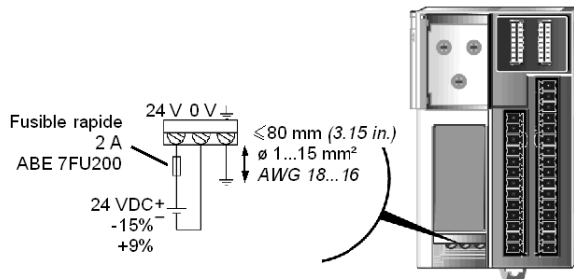

Grounding wire length should not exceed 80 mm (3.15 in.)

The sensor/actuator cables must be shorter than 30 m (98.4 ft.)

Wiring example: OTB 1•0DM9LP modules

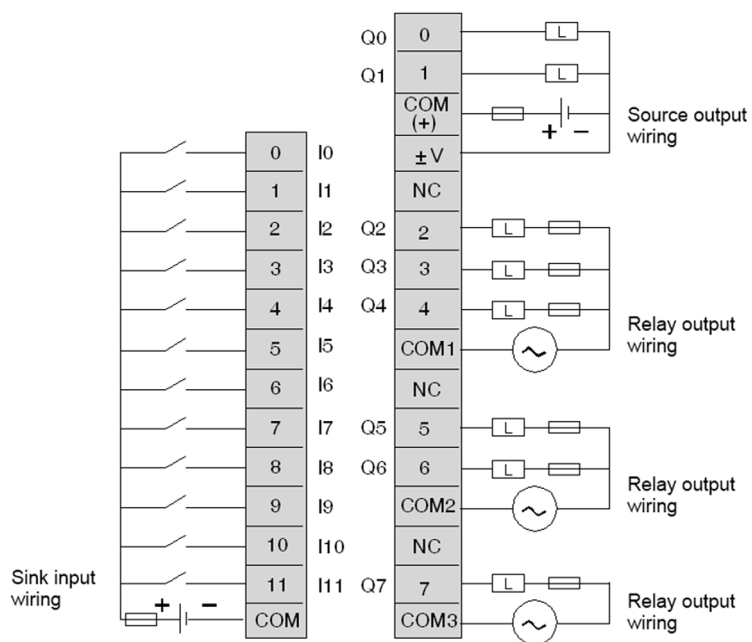

- Output points 0 and 1 are source transistor outputs, all other output points are relay.
- The COM terminals are **not** connected together internally.
- Connect an appropriate fuse for the load.

Modicon TM2 Modules - Hardware

Front View

Modicon TM2 expansion modules



Description

The range of Modicon TM2 expansion modules includes analog I/O modules, digital I/O modules, expert expansion modules, and communication expansion modules. Characterized by easy wiring and maintenance, these expansion modules offer a wide choice of modularity and so a large variety of automation configurations. The modules can be used in combination with 4 platforms: M238 bases, Modicon OTB, HMI controllers, and Twido bases.

The analog I/O expansion modules are compatible with sensors and suitable for economic and easy to use measurement. The digital I/O expansion modules are available in 3 wiring modes: screw terminals, high-density connectors, and spring terminals. The expert expansion modules are used for high speed counting in repetitive processes with advanced features like reflex outputs for enhanced accuracy.

- Fits customer application in the targeted market segments
- High level of quality and performance
- High EMC immunity for all modules
- Inputs and DC transistor outputs protected against short-circuits and polarity inversions
- All TM2 modules are RoHS compliant
- Low standard cost

Standards and certifications	Depends on the module: CE UL CSA UL/CSA class I, Div. 2, TÜV IEC EN 61131-2 edition 2 2003, cULus, Nemko - GL - LR - DNV
Power supply	Depends on the module: 24 Vdc or 120 Vac
Degree of protection	IP20

Dimensions	Depends on the module: (W x H x D): 21.2...42.9 x 90 x 95.6...117.2 mm (0.84...1.69 x 3.54 x 3.76...4.61 in.)
------------	---

For more information, refer to

- Modicon TM2, Analog I/O Modules, Hardware Guide, EIO0000000034
- Modicon TM2, Digital I/O Modules, Hardware Guide, EIO0000000028
- Modicon TM2, High Speed Counter Modules, Hardware Guide, EIO0000000022

Wiring

For a brief overview, refer to the 2 wiring examples below.

Wiring example TM2AMM3HT analog mixed I/O module

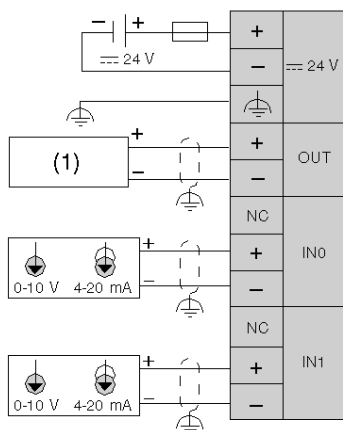

(1) Voltage/current preactuator

Wiring example: TM2DMM8DRT digital mixed I/O module

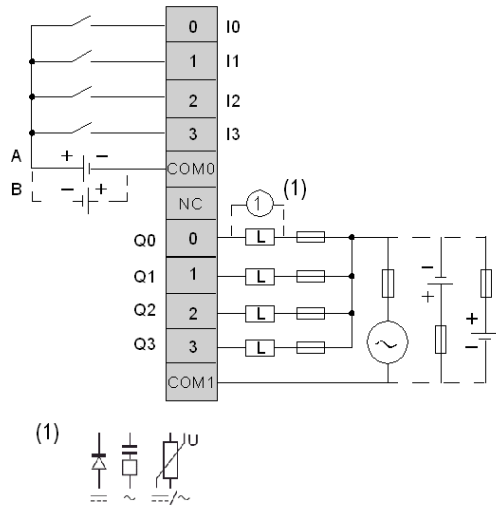

Section 4.5

Communication

ConneXium Ethernet Switch (Unmanaged) - Hardware

Front View

5-port TCSESU053FN0 Ethernet switch (unmanaged)



Description

The ConneXium unmanaged Ethernet switch range offers you a smart and flexible way to integrate Ethernet solutions into your operation, from the device level to the control network and to your corporate network.

Unmanaged devices are those which there is no possibility to configure or control any of the parameters of the devices. They support Ethernet 10 Mbit/s and Fast Ethernet 100 Mbit/s.

Furthermore the switch modules support switched Ethernet networks in accordance with IEEE standard 802.3 or 802.3u using copper and fiber optic technology.

All switches are mounted on a standard DIN rail.

- Multi-address capability
- Storage and rerouting of received data
- Data packets with VLAN tags are transmitted unchanged (IEEE 802.1 Q)
- Automatic negotiation of 10/100 Mbit/s and duplex mode

- Automatic change of polarity
- Low-cost wiring solution

Standards and certifications	UL508, CSA 22.2 No.142, CE
Power supply	24 Vdc
Operating voltage	9.6...32 Vdc
Ports	3, 4, 5,8
Degree of protection	IP 30
Dimensions	W x H x D: 25 x 114 x 79 mm (0.98 x 4.49 x 3.1 in.) (TCSESU053FN0)

For more information, refer to *ConneXium Ethernet Switches, TCSESU0••F•N0, Quick Reference Guide, 31007950.*

Wiring

TCSESU053FN0 connector overview

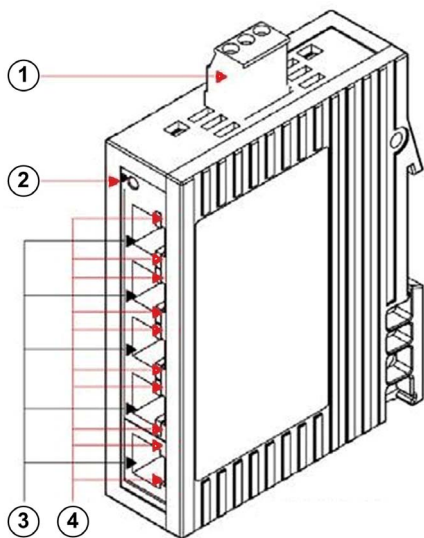

- 1 3-pin terminal block for power supply
- 2 Power indicator
- 3 10/100 base-TX (RJ45 connectors)
- 4 Port ACT/LNK LEDs

Section 4.6

Motor Control

What Is in This Section?

This section contains the following topics:

Topic	Page
TeSys D Contactor - Hardware	98
TeSys U LU2B Motor Starter- Hardware	100
TeSys GV2 Motor Circuit Breakers - Hardware	104
Altivar 32 Variable Speed Drive - Hardware	106
Lexium 28 Servo Drive - Hardware	110
Lexium 32i Servo Drive - Hardware	118

TeSys D Contactor - Hardware

Front View

TeSys D-LC1D contactor



Description

TeSys D-LC1D contactors are designed for all power switching, control applications, and integration into control systems.

They conform to standard IEC 60947-4-1, for utilization categories AC6b, as well as to UL/CSA standards.

This product constitutes a ready-to-use solution and offers you quick simple setup.

TeSys D contactors can be used to create motor starters for any type of application.

- AC, DC, and low-consumption DC control circuit
- All types of starter: reversing or non-reversing, star/delta, by auto-transformer, and so on.
- Various connectors: spring terminal, EverLink terminal block, screw clamp, ring-type connection, faston connector
- Easy and simple direct mounting between contactor and circuit breaker, according to EverLink terminal block (40...65 A)

Standards and certifications	IEC/EN 60947-4-1, IEC/EN 60947-5-1, UL 508, CSA C22.2 n° 14, UL, CSA, CCC, GOST, GL, DNV, RINA, VB, LROS
Rated operational current (Ie) in AC-3 (Ue max. 440 V)	9...150 A
Rated control circuit voltage (Uc)	12(24*)...690(500*) Vac 12(24*)...440 Vdc *D115 and D150
Degree of protection (front face)	IP 20 (conforming to IEC 60529)
Protective treatment	"TH" (conforming to IEC 60068-2-30)

Dimensions	19 different types without add-on blocks or cover (WxHxD): 45...155 x 77...158 x 84...132 mm (1.77...6.1 x 3.0...6.22 x 3.3...5.2 in.)
Options	Various connector types, wide range of auxiliary contact blocks and modules, power connection accessories, suppressor modules

For more information, refer to Control and protection components, MKTED210011EN.

Wiring

TeSys D09...150 3-pole contactors wiring diagram

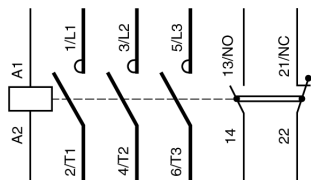

TeSys U LU2B Motor Starter- Hardware

Front View

TeSys U LU2B•• motor starter



Description

The TeSys U starter-controller is a Direct On Line (D.O.L.) starter which performs the following functions:

- Protection and control of single-phase or three-phase motors:
 - isolation and breaking function
 - overload and short-circuit protection
 - thermal overload protection
 - power switching
- Control of the application:
 - protection function indication
 - application monitoring (running time, number of errors detected, motor current values, and so on)
 - logs (last five errors detected are saved, along with motor parameter values)

These functions can be added by selecting control units and function modules which clip into the power base. This late customization is also possible after power and control circuit wiring has been completed.

From design through to operation, TeSys U offers advantages and simplifies the selection of components in comparison with a traditional solution.

- The braking, isolation, and contactor functions are incorporated in a single block. Therefore, there are fewer references to be ordered and selection is easy because a single reference covers most needs up to 15 kW.
- The control unit has a wide setting range. It can operate on a DC or an AC supply.

The compact components in the TeSys U range are mounted on a single rail, optimizing the amount of space required in enclosures. As power wiring between the circuit-breaker and contactor is not needed, TeSys U reduces installation times.

Setting-up accessories simplify or eliminate wiring between components, and allow easy selection and ordering.

With a capacity of up to 32 A/15 kW, TeSys U consists of:

- One 45 mm (1.77 in.) power base: two ratings, reversing or non-reversing, circuit-breaker function, and built-in interference suppression
- One clip-on control unit:
 - Standard CU: protection against overloads and short-circuits
 - Expandable CU: additional alarm and error differentiation
 - Multifunction CU: real-time control of motor load, local or remote diagnostics and parameter setting
- One clip-on automation control module: Modbus SL RS-485 2-wire, CANopen, AS-Interface, PROFIBUS DP, Ethernet, DeviceNet, Fipio, Interbus S via Advantys STB module or a simple parallel link
- Two optional 45 mm (1.77 in.) power functions: limiter-isolator and changeover relay

Standards and certifications	IEC/EN 60947-6-2, CSA C22-2 N° 14, Type E, UL508 type E: with phase barrier LU9SP0, UL, CSA, CCC, Gost, ASEFA, ABS, BV, DNV, GL, LROS, ATEX
Power range	0...15 kW at 400 V
Rated insulation voltage	<ul style="list-style-type: none"> • Conforming to IEC/EN 60947-1, overvoltage category III: 690 V • Conforming to UL508, CSA C22-2 n° 14: 600 V
Degree of protection	<ul style="list-style-type: none"> • Front panel outside connection zone: IP 40 • Front panel, wired terminals, and other faces IP 20
Dimensions	W x H x D: LUB: 45 x 154 (224*) x 135 mm (1.77 x 6.1 (8.8*) x 5.3 in.) *LU2B (reversible)

Options	<ul style="list-style-type: none"> ● Four different control units ● Error signaling modules ● Communication modules ● Auxiliary contact modules ● Load level modules ● Reverser block ● Plug-in terminal blocks ● Control circuit pre-wiring system
---------	---

For more information, refer to :

- Control and protection components, MKTED210011EN
- TeSys U, Starter-controllers, Catalogue, DIA1ED2081003EN

Components

TeSys U - non-reversing

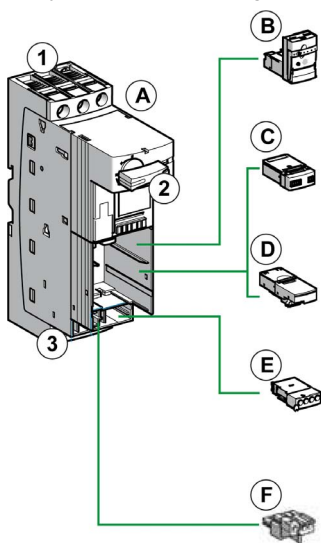

- 1 Power supply terminal block
- 2 On/Off/Reset control handle
- 3 "Motor" terminal block
- A Power base
- B Control units
- C Auxiliary contact modules (LUF), thermal overload signaling, error signaling modules, or load level modules
- D Communication modules
- E Auxiliary contact module (LUA)
- F Terminal block

TeSys U - reversing

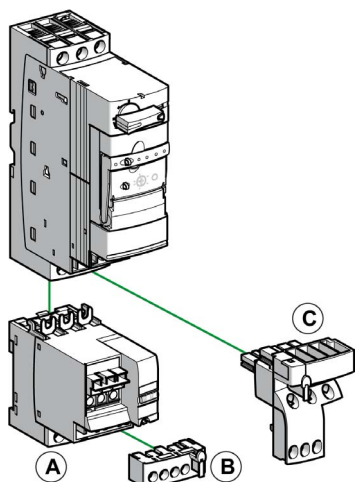

- A Reverser block
- B Plug-in terminal blocks
- C Control circuit pre-wiring system

A preassembled reversing power base can be ordered by a specific part number.

Wiring

TeSys U - reversing

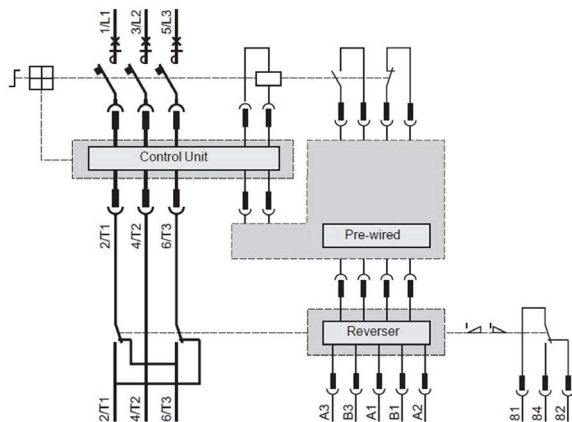

TeSys GV2 Motor Circuit Breakers - Hardware

Front View

TeSys GV2 P motor circuit breaker



Description

The large TeSys motor circuit-breakers range GV2, GV3 and GV7 is categorized according to their level of performance and functions. Due to its diverse characteristics, only the GV2 P is presented and integrated into the TVDA.

The TeSys GV2 P motor circuit-breakers are three-pole thermal-magnetic circuit-breakers designed for the control and protection of motors.

The motor protection is provided by the thermal-magnetic elements incorporated in the industrial motor circuit-breaker.

The magnetic elements (short-circuit protection) have a non-adjustable tripping threshold, which is equal to 13 times the maximum setting current of the thermal trips.

The thermal elements (overload protection) include automatic compensation for ambient temperature variations. The addition of an under voltage trip allows the circuit-breaker to be de-energized in the event of an under voltage condition.

- Motor and personnel protection
- Live parts are protected from direct finger contact
- Compact size
- Easy to install: screw mounting or clip-on mounting
- Control by rotary knob
- Connection by screw clamps

Standards and certifications	IEC 60947-1, 60947-2, 60947-4-1, EN 60204, UL508, CSA C 22.2 n° 14-05, NF C 63-650, 63-120, 79-130, VDE 0113, 0660, UL*, CSA, PTB, EZU, GOST, TSE, DNV, LROS, GL, BV, RINA, CCC, ATEX *UL508 type E for GV2 P•H7 (line spacer included)
Operational voltage	690 V

Degree of protection	IP 20
Dimensions	W x H x D: 44.5 x 89 x 97 mm (1.75 x 3.5 x 3.82 in.)
Options	<ul style="list-style-type: none"> ● Combination block ● Sets of 3-pole busbars ● Protective end cover ● Terminal blocks ● Padlock able external operator ● Contact blocks: Error signaling contact and immediate auxiliary contacts ● Undervoltage/Shunt trips ● Padlocking devices

For more information, refer to Control and protection components, MKTED210011EN.

Wiring

TeSys GV2 P contactors wiring diagram

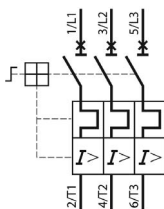

Altivar 32 Variable Speed Drive - Hardware

Front View

Altivar 32 variable speed drive



Description

The Altivar 32 drive is a frequency inverter for 200...500 V three-phase asynchronous and synchronous motors rated from 0.18 kW to 15 kW which includes a various motor control profile.

In combination with synchronous motors, Altivar 32 variable speed drives offer optimized energy efficiency.

It features more than 150 functions. It is robust, compact, and easy to install.

The Altivar 32 drive incorporates functions which are suitable for the most common applications, including: hoisting, material handling, packaging, and special machines (like wood working machines, metal processing, and so on).

- Compact book format
- Integrated Modbus SL RS-485 2-wire
- Open: communication cards available as options
- integrated protection
- Simple setup
- Integrated programmable logic functions
- Energy saving: control of energy efficient permanent magnet synchronous motors

Standards and certifications	IEC 61800-5-1, IEC 61800-3 (environments 1 and 2, category C2), ISO/EN13849-1/-2 (category 3, PL d), IEC 61508 (parts 1 & 2), IEC 60721-3-3 (environments 3C3 and 3S3, classes 3C3 and 3S2), UL508c, CSA, NOM, GOST, C-Tick
------------------------------	---

Power range	0.18...15 kW
Voltage range	<ul style="list-style-type: none"> ● single-phase 200...240 V (0.18 to 2.2 kW) ● three-phase 380...500 V (0.37 to 15 kW)
Output frequency	0.1...599 Hz
Transient overtorque	170...200 % of the nominal motor torque
Communication	<ul style="list-style-type: none"> ● integrated: Modbus SL RS-485 2-wire and CANopen, Bluetooth link ● optional: DeviceNet, PROFIBUS DP V1, Modbus SL RS-485 2-wire, EtherNet/IP, Modbus TCP, EtherCAT
Functions	<ul style="list-style-type: none"> ● standard or customizable configurations ● factory or OEM settings ● application-specific functions ● adjustable switching frequency ● HMI and dialog or configuration tools ● uploads and downloads with drive on or off
Protections	<ul style="list-style-type: none"> ● STO: Safe Torque Off ● SLS: Safely Limited Speed ● SS1: Safe Stop 1
I/Os	<ul style="list-style-type: none"> ● 3 analog inputs - response time: 3 ms, resolution 10 bits ● 6 logic inputs - response time: 8 ms, configurable in PTC and IN PWM ● 1 analog input - updating time: 2 ms ● 1 logic output - sampling time: 2 ms, configurable as voltage or current ● 2 relay outputs
Degree of protection	IP 20
EMC filter	<ul style="list-style-type: none"> ● integrated: C2 EMC ● optional: C1 EMC
Dimensions	<p>4 types (WxHxD)</p> <ul style="list-style-type: none"> ● 45 x 317 x 245 mm (1.77 x 12.48 x 9.65 in.) ● 60 x 317 x 245 mm (2.36 x 12.48 x 9.65 in.) ● 150 x 308 (232*) x 232 mm (5.9 x 12.13 (9.13*) x 9.13 in.) ● 180 x 404 (330*) x 232 mm (7.1 x 15.9 (13*) x 9.13 in.) <p>* = EMC plate not installed</p>
Options	<ul style="list-style-type: none"> ● SoMove and SoMove Mobile setup software ● simple and multi-loader configuration tool ● remote display terminals ● communication cards in cassette format ● optimized offer for connection to the CANopen bus ● quick connect for a TeSys GV2 circuit breaker

For more information, refer to :

- Altivar 32, Variable speed drives for synchronous and asynchronous motors, Installation manual, S1A28686 (ENG).
- Altivar 32, Variable speed drives for synchronous and asynchronous motors, Programming manual, S1A28692 (ENG).

Wiring

Altivar 32 connector overview

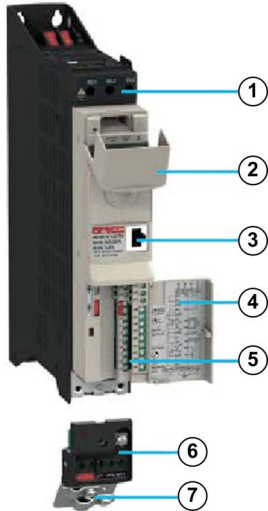

- 1 Power terminals
- 2 Protective cover
- 3 RJ45 Modbus SL RS-485 2-wire
- 4 Protective cover
- 5 Control terminals
- 6 Removable motor power terminal block
- 7 EMC mounting plate

Wiring example power supply and motor

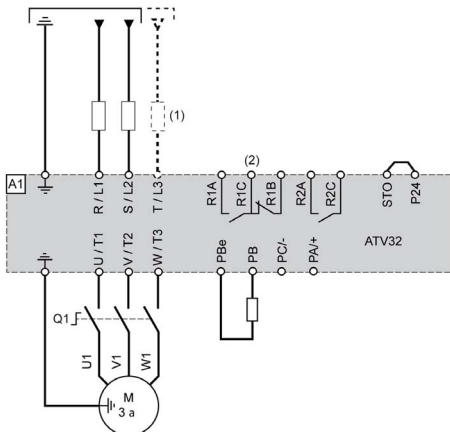

- (1) Line choke (if used)
- (2) Relay contacts signifying detected errors

Lexium 28 Servo Drive - Hardware

Front View

Lexium 28 servo drive



Description

The Lexium 28 is an all-purpose AC servo drive. Together with series BCH2 servo motors as well as a comprehensive portfolio of options and accessories, the drives are ideally suited to implement compact, high performance drive solutions for a wide range of power requirements.

- Integrated CANopen / CANmotion communication
- Integrated safety function STO (Safe Torque Off)
- I/O interface with numerous digital and analog I/Os
- Numerous servo drive functions supported such as positioning, speed, and torque control
- Compact size
- Easy to configure and set up with SoMove configuration software and the auto-tuning function

Power range	50 W...4.5 kW
Voltage range	1 or 3 phase, 200 – 10%...230 + 10% Vac
Speed	Up to 5000 rpm
Torque	Up to 28.65 Nm
Communication	<ul style="list-style-type: none"> ● CANopen, CANmotion machine bus ● Modbus for commissioning

Operating modes	<ul style="list-style-type: none">● Speed control mode● Position control mode● Torque control mode● Jog mode● Homing
Safety-related functions	STO (Safe Torque Off) function as per IEC 61800-5-2
Inputs/outputs	<ul style="list-style-type: none">● 8 digital inputs● 5 digital outputs● 2 analog inputs ± 10 V● 2 analog outputs ± 10 V● 1 output for ESIM (encoder simulation)● 1 PTI (Pulse Train Input) with high or low speed inputs
Degree of protection	IP20
Dimensions	6 types (W x H x D) 55...117.4 x 173.2...194.5 x 152.7 mm (2.16...4.62 x 6.82...7.66 x 6.01 in.)
Options	<ul style="list-style-type: none">● Commissioning software SoMove● Cables and connectors● External mains filters● DC bus accessories

Physical Description

Front view of the Lexium 28

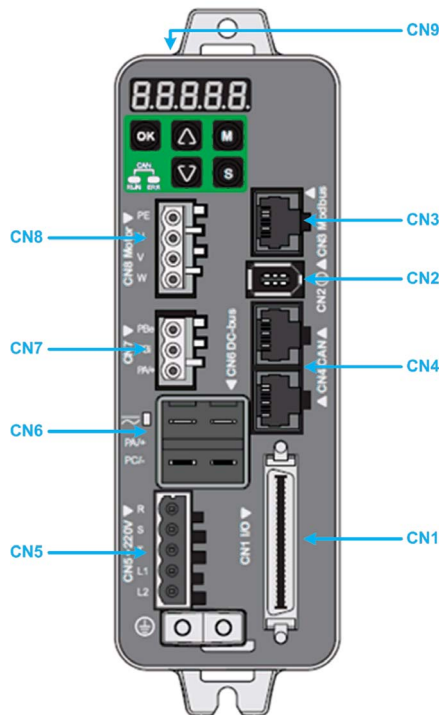

Connector	Description
CN1	I/O interface connector
CN2	Motor encoder connector
CN3	RJ45 connector – Modbus (commissioning interface)
CN4	RJ45 dual port connector (in/out) - CAN interface
CN5	<ul style="list-style-type: none"> ● R/S/T: Power stage supply ● L1/L2: Controller power supply
CN6	DC bus connector for parallel operation
CN7	External braking resistor
CN8	Motor phases
CN9	STO (Safe Torque Off) connector

Wiring

In this section, a selection of wiring examples is depicted to provide an overview on how to install the Lexium 28 servo drive in an automation system. For detailed information on wiring and installation of the Lexium 28 servo drive, refer to the document LXM28A and BCH2, Servo drive system, Product manual, 0198441114054-EN.

Wiring example power stage and controller power supply

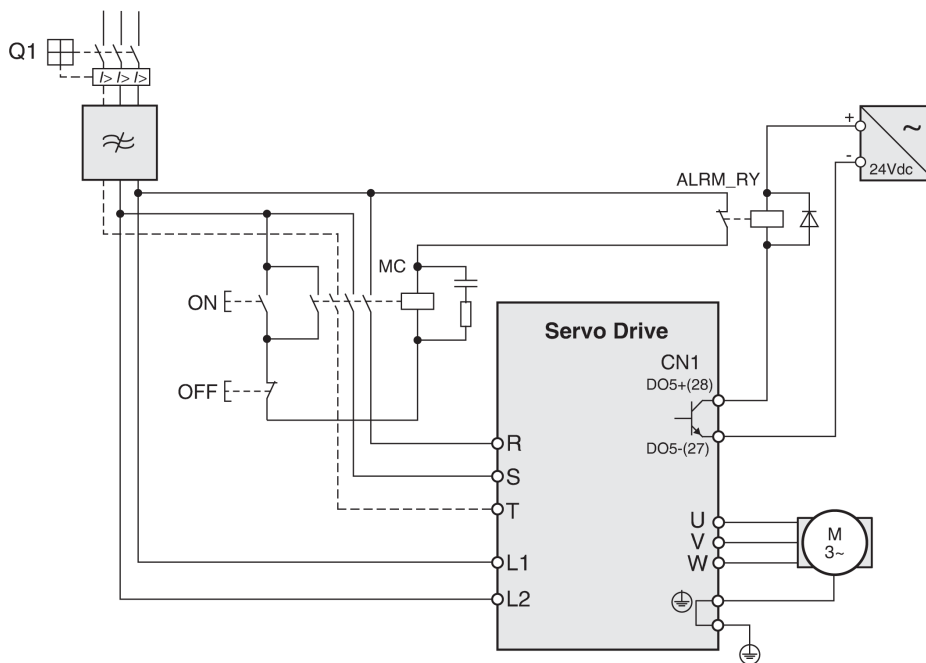

Wiring example STO with category 0 stop (IEC 60204-1)

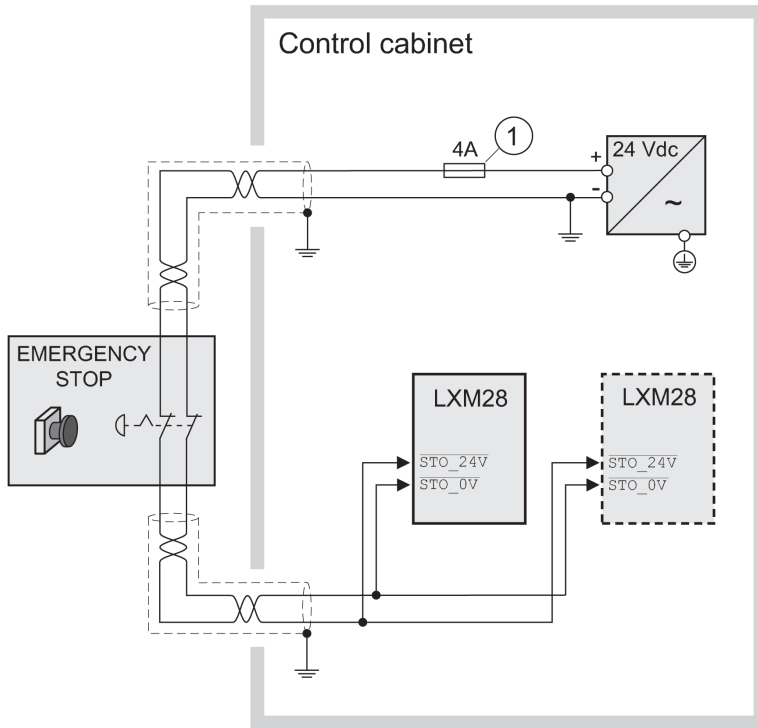

Wiring example digital input (logic type 1) with internal power supply

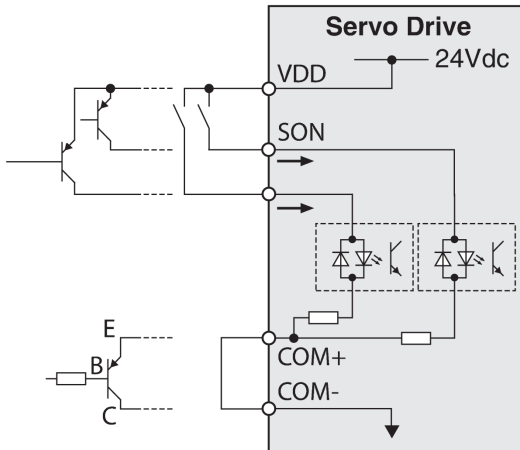

Wiring example digital input (logic type 1) with external power supply

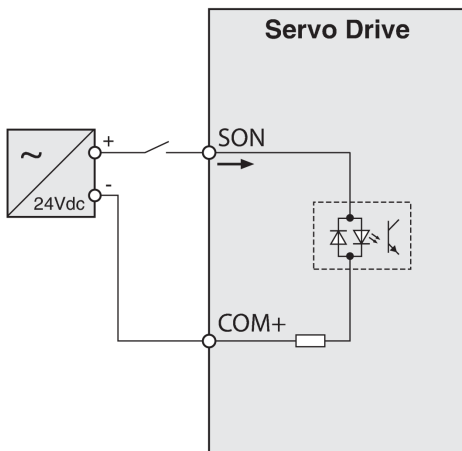

Wiring example digital output (logic type 1) with internal power supply

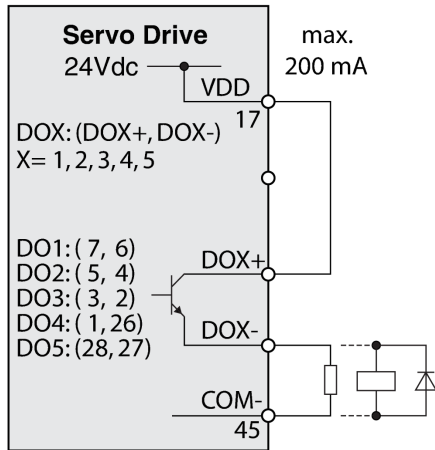

Wiring example digital output (logic type 1) with external power supply

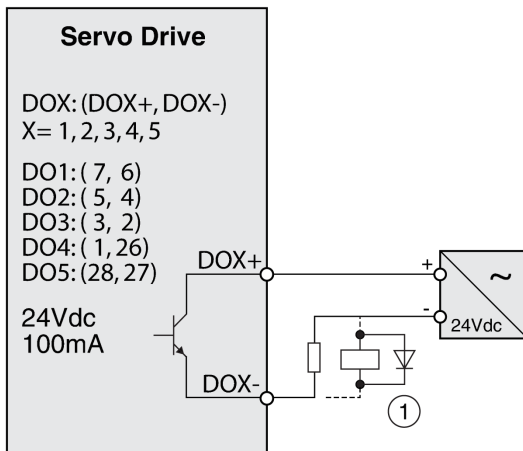

Wiring example pulse input (open collector) with external power supply.

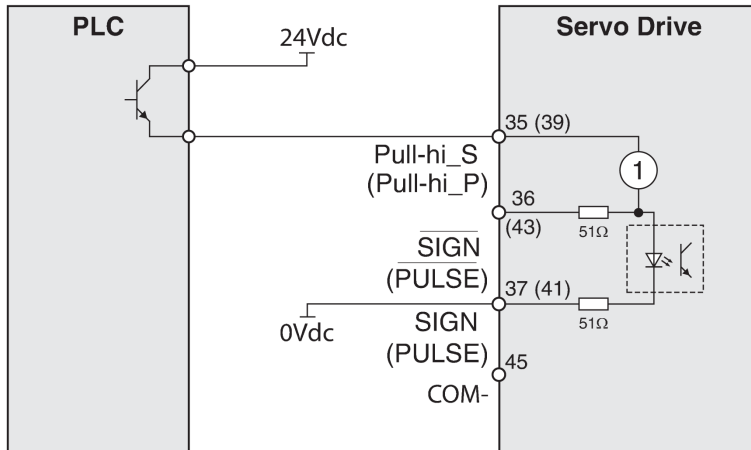

Lexium 32i Servo Drive - Hardware

Front View

Lexium 32i servo drive



Description

With servo motor, servo drive, power supply connector, and I/O and fieldbus module integrated in one housing, the compact Lexium 32i (integrated) is designed for application areas requiring high precision and advanced motor control.

The modular components of the product family Lexium 32i (integrated) can be composed to meet the requirements of a large variety of applications. Minimum wiring as well as a comprehensive range of options and accessories allowing to implement compact, high-performance drive solutions for a wide range of power requirements. Typical application areas for the integration of the Lexium 32i (integrated) are: Material handling, material working, packaging, printing, and so on.

- Easy selection of the catalog components using the on-line configurator
- Easy to integrate with standard fieldbusses and software
- No cabinet space needed for the drive
- Reduce costs by up to 30%
- Easy to assemble and to maintain
- Memory cards allow for copying of parameters and fast device replacement

Standards and certifications	TÜV Nord, UL, CSA, CiA (CAN in automation)
Power range	0.6 (0.8*)...1.3 (2.2*) kW *3-phase

Voltage range	<ul style="list-style-type: none"> ● 1-phase, 115...240 Vac ● 3-phase, 400...480 Vac
Speed	up to 3600 rpm
Torque	up to 7.8 Nm
Communication	Modbus serial link, CANopen, CANmotion, EtherCAT
Operating modes	Homing, manual mode (JOG), speed control, current control, position control
Functions	<ul style="list-style-type: none"> ● Auto-tuning, monitoring, stopping, conversion ● Stop window ● Rapid entry of position values
I/Os	4 logic inputs (24 Vdc) 2 logic outputs (24 Vdc)
Protections	"Safe Torque Off" (STO)
Degree of protection	<ul style="list-style-type: none"> ● Casing: IP 65 ● Shaft end: IP 54 or IP 65
Flange size	70/100 mm (2.76/3.94 in.)
Options	<ul style="list-style-type: none"> ● 2 drive control units ● 18 motors with power stage ● various connector modules ● SoMove setup software ● Memory card ● Sealing ring ● External braking resistors

For more information, refer to LXM32iCAN BMi, Lexium 32 Integrated, Product manual, 0198441113950 (ENG).

Assembly

Lexium 32i components

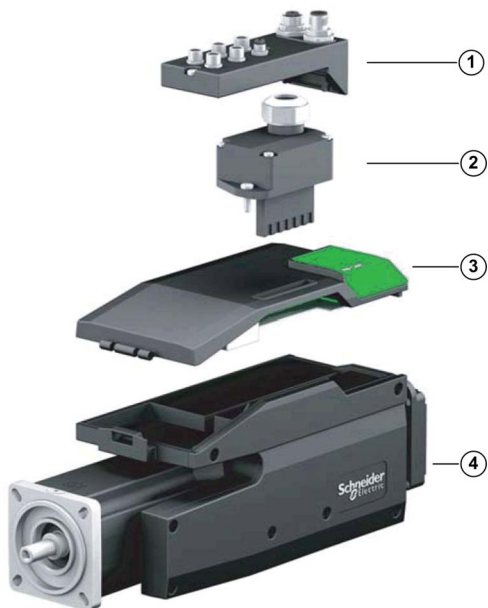

- 1 I/O and fieldbus connector module
- 2 Power supply connector module
- 3 Drive control unit
- 4 Motor with power stage

Wiring

Wiring example

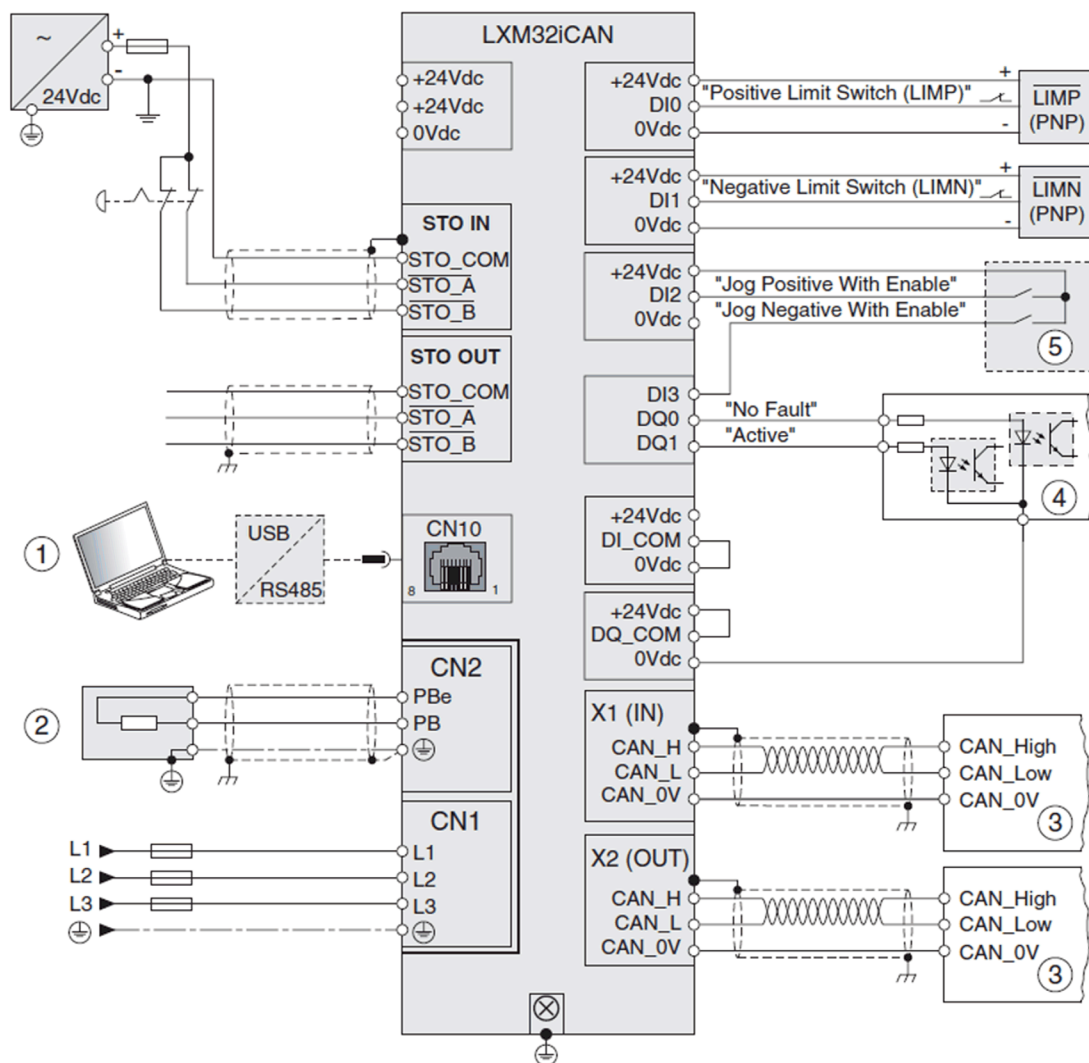

- 1 Commissioning accessories
- 2 Standard or external braking resistor
- 3 CANopen bus device
- 4 Signal lights or inputs of the controller
- 5 Test box for commissioning

Section 4.7

Detection

OsiSense Industrial Sensors - Hardware

Front View

OsiSense industrial sensors product range



Description

Under the Telemecanique Sensors brand, the latest innovations in the field of sensors for industrial detection operations are offered.

The OsiSense product range consists of safety and limit switches, pressure control sensors, ultrasonic sensors, inductive and capacitive proximity sensors, and so on.

For more information, refer to [Detection for automation solutions OsiSense, MKTED210041EN](#).

Chapter 5

Communication Topology and Wiring Guide

What Is in This Chapter?

This chapter contains the following sections:

Section	Topic	Page
5.1	Introduction to System Communication	124
5.2	CANopen/CANmotion Network	125
5.3	Ethernet Network	145
5.4	Modbus Serial Line Network	150

Section 5.1

Introduction to System Communication

Introduction

Overview

The TVDA (Tested Validated Documented Architecture) includes 4 different communication networks.

- **CANopen**
The CANopen fieldbus is defined with the Magelis SCU HMI Controller as CANopen master. The Altivar 32 drives, Lexium drives (Lexium 28, and Lexium 32i), TeSys U, and Modicon OTB are CANopen slave nodes.
The CANopen transmission rate is 500 kbps.
- **Modbus SL**
The Modbus SL RS-485 2-wire network is used for the communication between the Magelis SCU HMI Controller (master) and the energy meter iEM3150 (slave).
- **Ethernet**
A PC can be connected to the Ethernet interface of the Magelis SCU HMI Controller for downloading and online monitoring of the application.
- **USB**
In this architecture, a biometric USB switch is linked to the USB interface (type A) of the Magelis SCU HMI Controller. A second USB interface (type mini B) can be used for downloading and monitoring of the application.

Section 5.2

CANopen/CANmotion Network

What Is in This Section?

This section contains the following topics:

Topic	Page
CANopen Network Topology	126
CANopen Network Wiring	127
Magelis SCU HMI - CANopen Wiring	132
TeSys U Communication Module LULC08 - CANopen Wiring	133
Altivar 32 Variable Speed Drive - CANopen Wiring	135
Lexium 28 - CANopen Wiring	137
Lexium 32i Servo Drive - CANopen Wiring	139
Modicon OTB - CANopen Wiring	142

CANopen Network Topology

CANopen Topology

The baud rate used is 500 kbps.

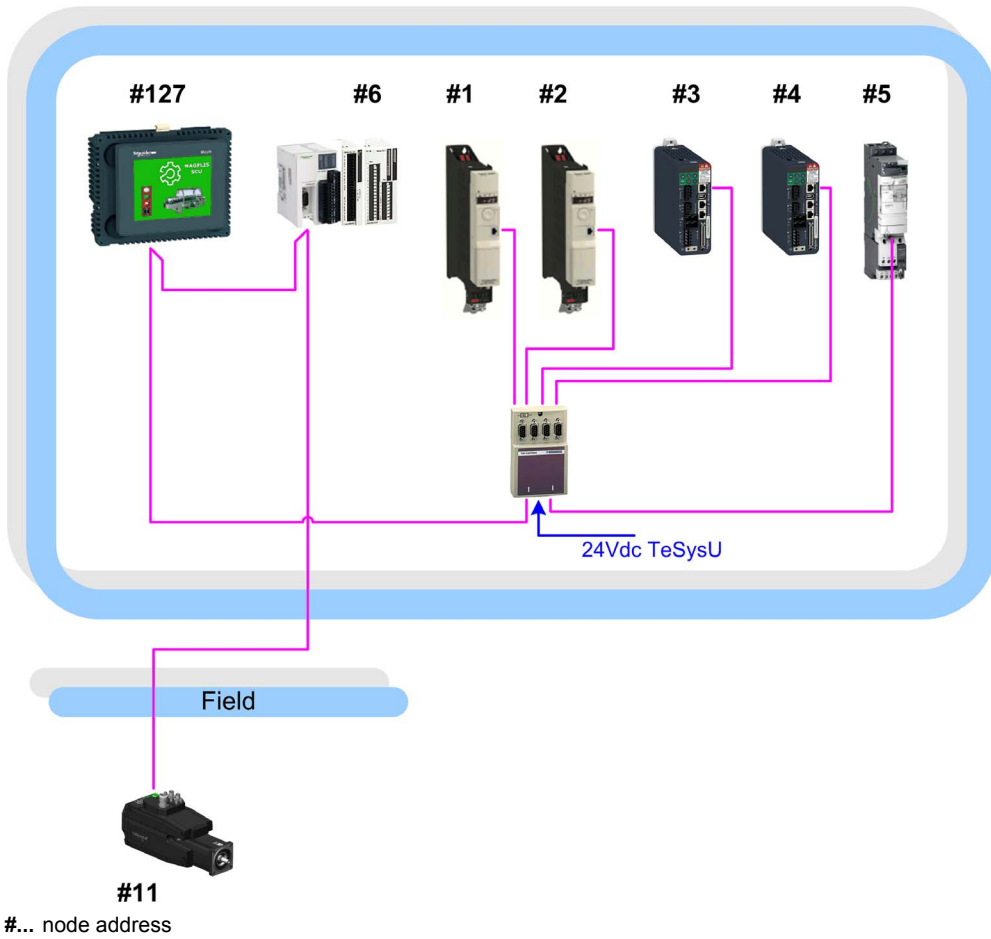

CANopen Network Wiring

CANopen Overview

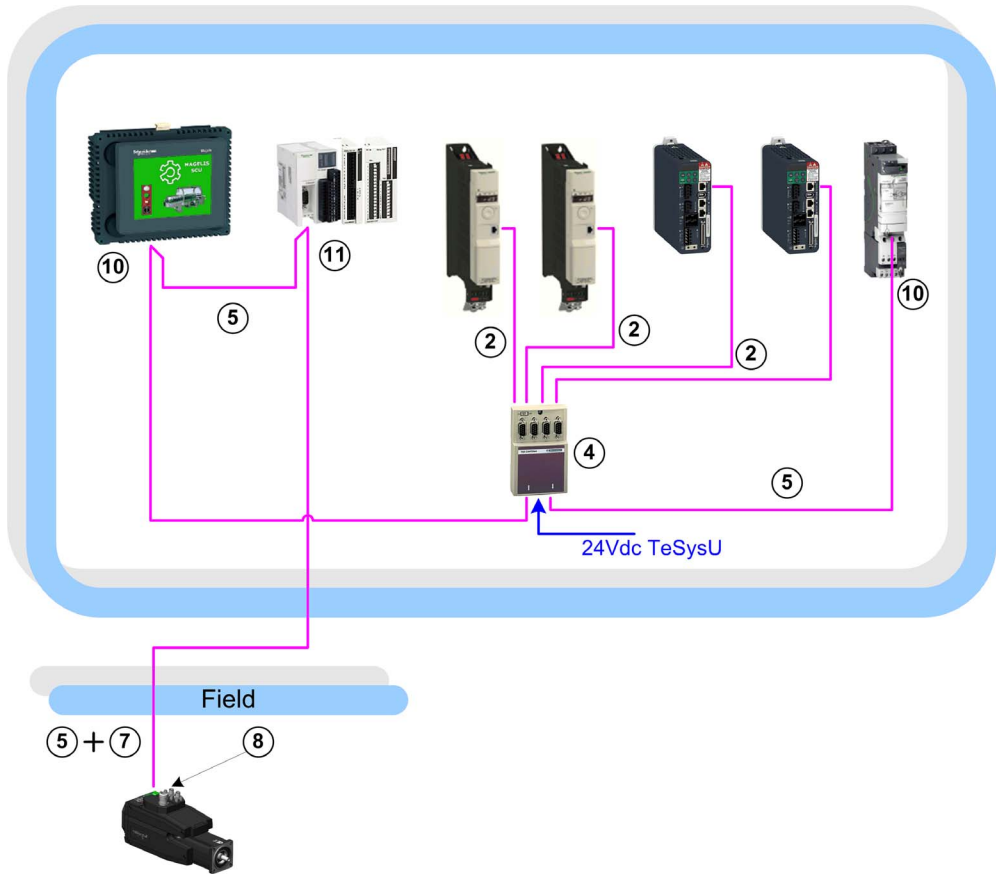

For the position numbers, refer to table below.

For more information, refer to CANopen, Hardware Setup Manual, 35010857.

CANopen Wiring

Position Number	Reference	Designation	Description	Cable Length
1	TSX CAN CADD03	preformed cordset standard, CE marking: low smoke emission, zero halogen. flame-retardant (IEC 60332-1)	one 9-way female SUB-D connector at each end	0.3 m (0.98 ft)
	TSX CAN CADD1			1.0 m (3.28 ft)
	TSX CAN CADD3			3.0 m (9.84 ft)
	TSX CAN CADD5			5.0 m (16.40 ft)
2	TCS CCN 4F3M05T	preformed cordset	one 9-way SUB-D connector, one RJ 45 connector	0.5 m (1.64 ft)
	TCS CCN 4F3M1T			1.0 m (3.28 ft)
	TCS CCN 4F3M3T			3.0 m (9.84 ft)
3	VW3 CAN CARR03	preformed cordset	one RJ 45 connector at each end	0.3 m (0.98 ft)
	VW3 CAN CARR01			1.0 m (3.28 ft)
4	TSX CAN TDM4	IP20 CANopen tap junction	4 SUB-D ports, screw terminal block for connecting the trunk cables, line termination	-
5	TSX CAN CA***	dedicated to the European market low smoke emission, zero halogen, fire retarding	CANopen cable	50 m (164 ft)
	TSX CAN CB***	dedicated to the American market, UL and CSA certified, fire retarding		100 m (328 ft)
	TSX CAN CD***	flexible cable for severe environments, good chemical resistance to oil and grease, low smoke emission, zero halogen, fire retarding and ready for mobile applications		300 m (984 ft)
6	FTX CN 3203	preformed cordset	two 5-way M12 A-coded angled connectors (one male connector and one female connector)	0.3 m (0.98 ft)
	FTX CN 3206			0.6 m (1.96 ft)
	FTX CN 3210			1.0 m (3.28 ft)
	FTX CN 3220			2.0 m (6.56 ft)
	FTX CN 3230			3.0 m (9.84 ft)
	FTX CN 3250			5.0 m (16.40 ft)
7	FTX CN 12F5	IP67 M12 connectors	5-way M12 A-coded connectors female	-
8	TM7ACTLA	IP67 line terminator	equipped with one M12 connector (for end of bus)	-

Position Number	Reference	Designation	Description	Cable Length
9	TCS CAR 013M120	IP20 line terminator	RJ 45 termination resistor (for end of bus)	–
10, 11	TSX CAN KCDF90T	IP20 connectors CANopen female 9-way SUB-D, switch for line termination	90° angled	–
	TSX CAN KCDF180T		straight	
	TSX CAN KCDF90TP		right angle with 9-way SUB-D for connecting a PC or diagnostic tool	

IP67 M12 Cable Connector

Schneider Electric provides 2 types of IP67 M12 connectors:

male	FTX CN 12M5
female	FTX CN 12F5

IP67 M12 cable connector (5-pin M12 male BUS IN, female BUS OUT):



Pin assignment of the BUS IN and BUS OUT connector pins:

Pin	Signal	Meaning
1	(CAN_SHLD)	optional CAN shield
2	(CAN_V+)	optional CAN external positive supply
3	CAN_GND	CAN ground
4	CAN_H	CAN_H bus line
5	CAN_L	CAN_L bus line

The wiring connection has to comply with the combinations described in the table above.

SUB-D 9 Cable Connectors

Schneider Electric provides the following types of SUB-D 9 cable connectors:

Schneider Electric Cable Connector	Characteristics
TSX CAN KCDF90T	90° cable
TSX CAN KCDF180T	180° cable
TSX CAN KCDF90TP	<ul style="list-style-type: none"> ● 90° lead ● male connector available for temporary connection of a diagnostic tool

The figure below shows the wiring of TSX CAN KCDF90T, TSX CAN KCDF180T and TSX CAN KCDF90TP:

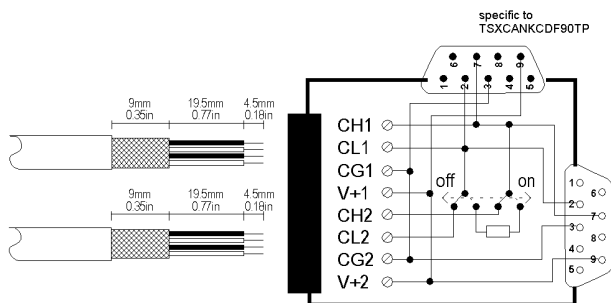

When using the Schneider Electric standard CANopen cable (TSX CAN CA***, TSX CAN CB*** or TSX CAN CD***), comply with the wiring combinations (signal, wire color) described in the table below.

The table shows terminal block wiring depending on the signal:

Pin	Signal	Terminal Block 1, Incoming Cable	Terminal Block 2, Outgoing Cable	Wire Color	Meaning
1	N.C.	–	–	–	not connected
2	CAN_L	CL1	CL2	blue	CAN_L bus line
3	CAN_GND	CG1	CG2	black	CAN ground
4	N.C.	–	–	–	not connected
5	(CAN_SHLD)	–	–	–	optional CAN shield
6	GND	–	–	–	ground, connection to pin 3
7	CAN_H	CH1	CH2	white	CAN_H bus line
8	N.C.	–	–	–	not connected
9	(CAN_V+)	V+1	V+2	red	optional CAN external positive supply

The wiring connection has to comply with the combinations described in the table above.

TSX CAN TDM4

The TSX CAN TDM4 tap allows connection of 4 devices by branching the drop cable to the 4 male SUB-D 9 plugs.

A line termination switch is provided to switch a built-in termination resistor. If the line termination switch is ON, the signals `CAN_H` and `CAN_L` of the outgoing cable are disconnected.

TSX CAN TDM4 with line termination switch

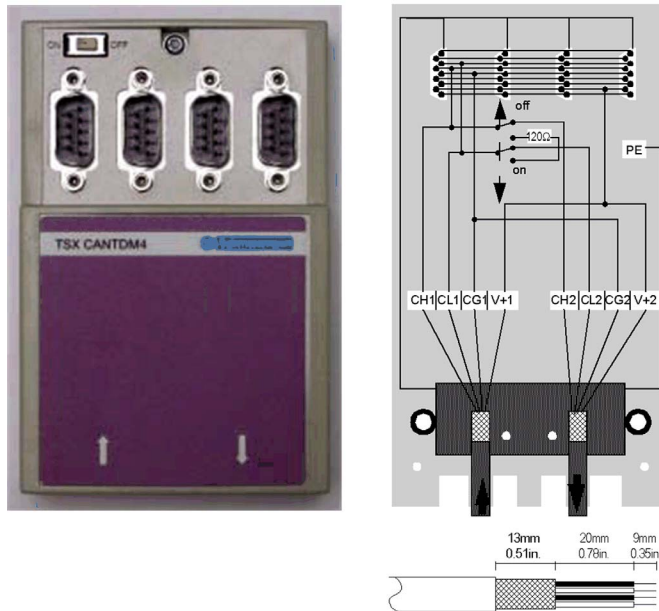

The wiring connection has to comply with the combinations described in the following table.

The table shows terminal block wiring depending on the signal:

Signal	Terminal Block 1	Terminal Block 2	Wire Color	Description
<code>CAN_H</code>	CH1	CH2	white	<code>CAN_H</code> bus line
<code>CAN_L</code>	CL1	CL2	blue	<code>CAN_L</code> bus line
<code>CAN_GND</code>	CG1	CG2	black	CAN ground
<code>CAN_V+</code>	V+1	V+2	red	optional CAN external positive supply

NOTE: When using devices which require a 24 Vdc power supply on CANopen line (such as TeSys U) the 24 Vdc power has to be wired (V+1: 24 Vdc, CG1: 0 Vdc).

Magelis SCU HMI - CANopen Wiring

CANopen Connector

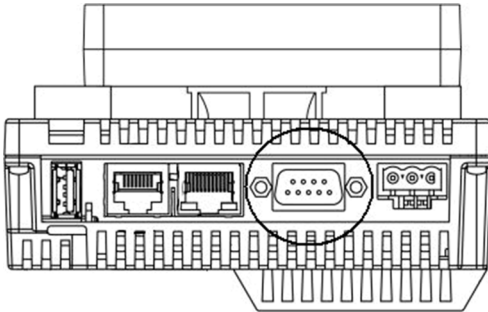

Pin Assignment

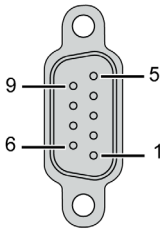

Pin	Signal	Description
1	N.C.	not connected
2	CAN_L	CAN_L bus line (low)
3	CAN_GND	CAN ground
4	N.C.	not connected
5	N.C.	not connected
6	GND	0 Vdc
7	CAN_H	CAN_H bus line (high)
8	N.C.	not connected
9	N.C.	not connected

TeSys U Communication Module LULC08 - CANopen Wiring

Bottom View

Bottom view of a TeSys U communication module LULC08

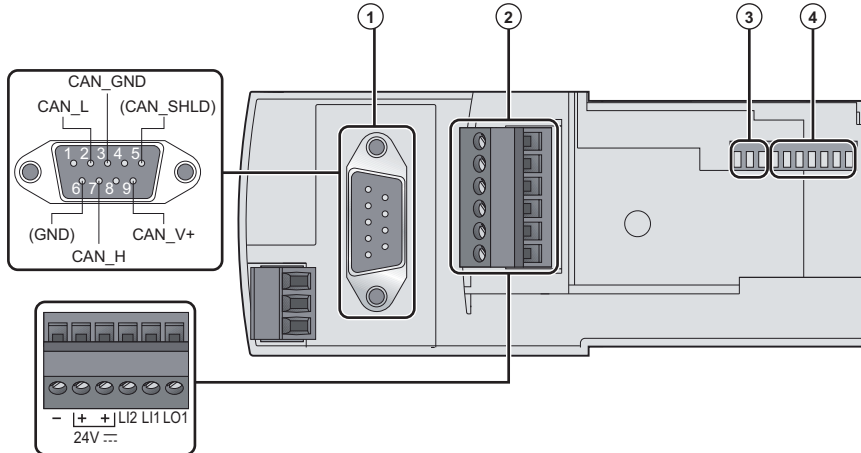

- 1 CANopen SUB-D 9 connector
- 2 Input/output terminal block and 24 Vdc
- 3 Baud rate
- 4 Address

NOTE: The 24 V power supply of the LULC08 is internally connected to the CAN_V+ pin of the CANopen connector and must be provided with the CAN link. If you do not use the CANopen sensor power supply for your application, do not connect the CAN_V+ wire of the outgoing CAN cable to the pin 9 of the LULC08 communication module.

Address Setting

The address of the communication module on the CANopen bus is the node ID. The system allows you to assign an address from 1 to 127, using the 7 right-most switches (SW1 to SW7). Address 0 (zero) is not allowed and is considered as an invalid configuration.

Example: Node address = 21 ($2^4 + 2^2 + 2^0$)

SW7 (2^6)	SW6 (2^5)	SW5 (2^4)	SW4 (2^3)	SW3 (2^2)	SW2 (2^1)	SW1 (2^0)
OFF	OFF	ON	OFF	ON	OFF	ON

Baud Rate

The system allows you to assign a baud rate using the 3 left-most switches (SW8 to SW10). The baud rate is according to the decimal value of the switches and will be interpreted as follows: 0 = 10, 1 = 20, 2 = 50, 3 = 125, 4 = 250, 5 = 500, 6 = 800 and 7 = 1000 kbps.

Example: Baud rate = 500 kbps (2^2+2^0)

SW10 (2^2)	SW9 (2^1)	SW8 (2^0)
ON	OFF	ON

Altivar 32 Variable Speed Drive - CANopen Wiring

Altivar 32 with Dual RJ45 Connector (VW3 A36 08)

For this architecture, the Altivar 32 variable speed drive has been equipped with the CANopen communication adapter VW3 A36 08 (dual RJ45 connector).

Using this adapter allows to daisy chain the CAN bus between the Altivar 32 drives.



NOTE: Maximum bus length are divided by 2 with the communication adapter (VW3 A36 08)
Both RJ45 are interconnected internally as on the diagram below:

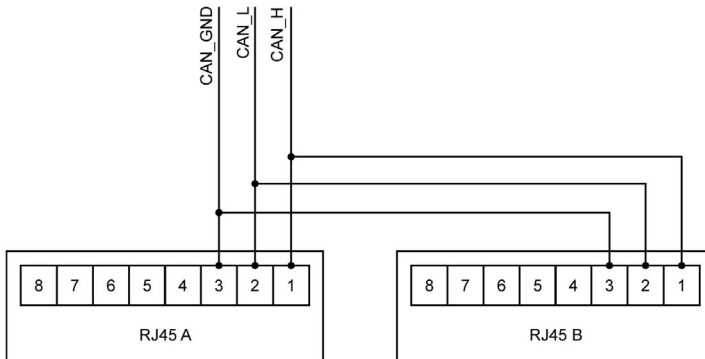

Pin Assignment

Pin	Signal	Description
1	CAN_H	CAN_H bus line
2	CAN_L	CAN_L bus line
3	CAN_GND	CAN ground
4	N.C.	not connected
5	N.C.	not connected
6	N.C.	not connected
7	N.C.	not connected
8	N.C.	not connected

Communication Settings

The Altivar 32 has to be configured for the operation on the CANopen fieldbus (node address, baud rate, and control channel). This can be done either via the local HMI on the front or via a commissioning software, for example, SoMove.

Lexium 28 - CANopen Wiring

Overview

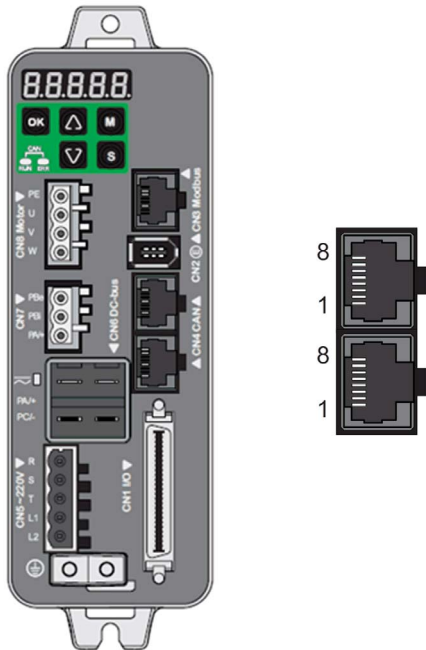

Lexium 28 servo drives can be directly connected to the CANopen/CANmotion fieldbus using the RJ45 connector. To simplify daisy chain connection, each servo drive is equipped with two RJ45 connectors (marked **CN4 CAN**). The communication function provides access to the configuration, adjustment, control, and monitoring functions of the servo drive.

Pin Assignment

Pin	Signal	Description
1	CAN_H	CAN_H bus line (dominant high)
2	CAN_L	CAN_L bus line (dominant low)
3	CAN_GND	CAN ground
4...6	N.C.	Not connected
7	CAN_GND	CAN ground
8	N.C.	Not connected

Communication Settings

The Lexium 28 has to be configured for the operation on the CANopen bus. This can be done either via the local HMI on the front or via a commissioning software, for example, SoMove.

For more information, refer to LXM28A and BCH2, Servo drive system, Product manual, 0198441114054-EN.

Lexium 32i Servo Drive - CANopen Wiring

Overview

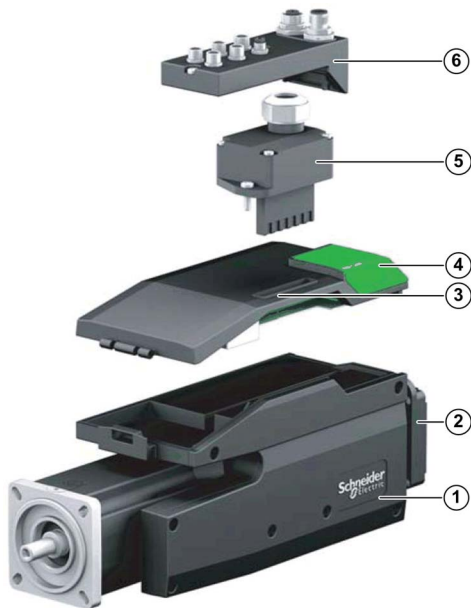

- 1 BMi servomotor with integrated power stage
- 2 Standard braking resistor or connection module for external braking resistor
- 3 Lexium 32i control unit for CAN fieldbus
- 4 Cover of commissioning interface
- 5 Connection module for supply voltage
- 6 I/O module / connection module for fieldbus, inputs/outputs and STO, versions with terminal box or industrial connector

I/O Module with Industrial Connectors

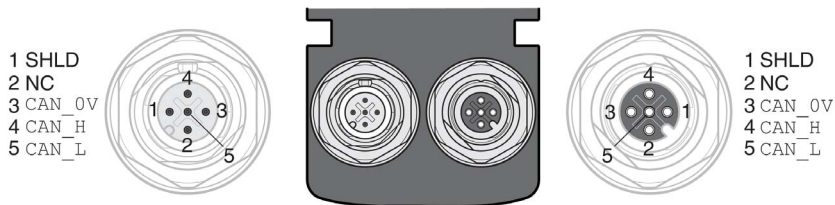

Commissioning Interface

The following components can be found below the cover of the commissioning interface:

- DIP switch for address and baud rate
- card holder for the memory card
- commissioning interface CN10

The cover of the commissioning interface can be opened with a flat blade screwdriver.

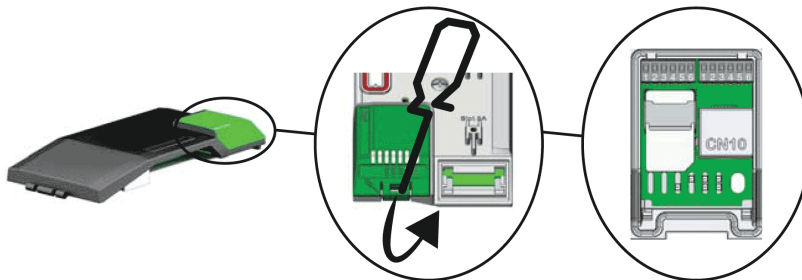

With the factory settings active, the address and the baud rate can be set via the parameters `CANbaud` and `CANaddress`. It is also possible to set the address and the baud rate via the DIP switches located below the cover of the commissioning interface. If the DIP switches are used, the values set via the parameters are ignored.

Address Setting

DIP switch device address (example to the right: device address 13 with DIP switches)

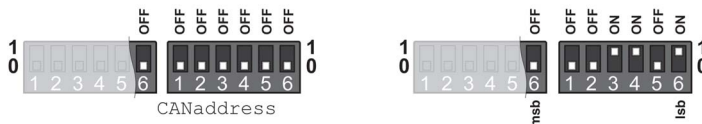

Example: Node address = 13 ($2^3+2^2+2^0$)

Switch	6	1	2	3	4	5	6
Address bit	6 (2^6)	5 (2^5)	4 (2^4)	3 (2^3)	2 (2^2)	1 (2^1)	0 (2^0)
State	OFF	OFF	OFF	ON	ON	OFF	ON

Baud Rate

The following DIP switch settings to assign the baud rate are possible. The settings for CANbaud means the baud rate has to be set by the commissioning software via the parameter CANbaud.

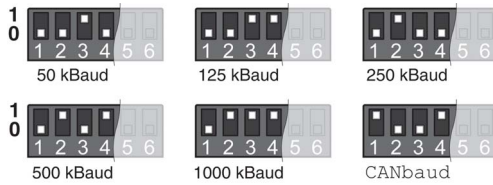

Modicon OTB - CANopen Wiring

Overview

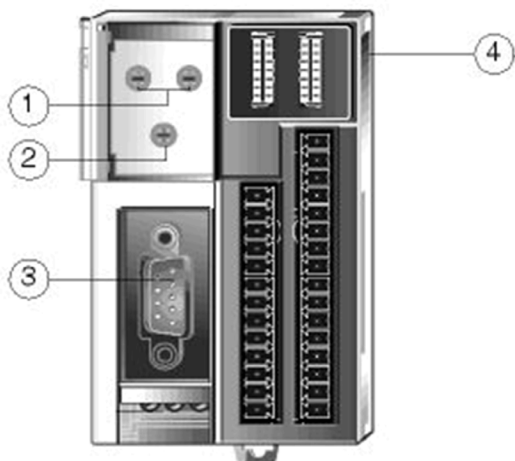

- 1 + 2 Rotary switches to configure the communication settings
- 3 Male 9-pin SUB-D connector for CANopen fieldbus
- 4 Indicator LED for visual information on the operational state of the CANopen fieldbus

Pin Assignment

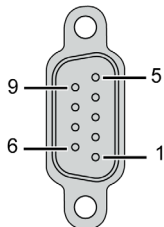

Pin	Signal	Description
1	N.C.	not connected
2	CAN_L	CAN_L bus line (low)
3	CAN_GND	CAN ground
4	N.C.	not connected
5	N.C.	not connected
6	GND	0 Vdc

Pin	Signal	Description
7	CAN_H	CAN_H bus line (high)
8	N.C.	not connected
9	N.C.	not connected

Parameter Switches

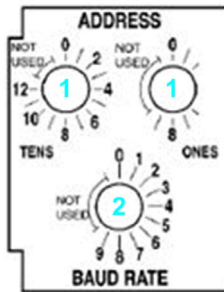

- 1 Rotary switch to configure the address
- 2 Rotary switch to configure the baud rate

Address Settings

The instructions for configuring the address of the island are described in the table.

Step	Action	Comment
1	All power supply to the island must be OFF	The changes you make will be detected on the next power-up
2	Select an island address	Select an address that is not already in use on your fieldbus network
3	Adjust the upper rotary switches: <ul style="list-style-type: none"> ● Left rotary switch: 0 to 12 (tens) ● Right rotary switch: 0 to 9 (unit figures) 	Address range: 1...126
4	Power up the island in order to implement the new configuration	The network interface module reads the rotary switch adjustments only on power-up

NOTICE

UNINTENDED EQUIPMENT OPERATION

Do not use an address outside of the specified range (from 1 to 126).

Failure to follow these instructions can result in equipment damage.

Baud Rate

The instructions for configuring the baud rate are given in the table.

Step	Action	Comment
1	All power supplies to the OTB network interface module must be off	The changes you make will be detected on the next power-up
2	Select the rate in bauds to be used for CANopen fieldbus communications	The rate configuration depends on your system and network specifications
3	Set the lower rotary switch to the position corresponding to the required rate	Use the following rate selection table
4	Power up the OTB network interface module again to apply the new configuration	The network interface module only reads the rotary switch parameters on power-up

Position (Lower Rotary Switch)	Baud Rate
0	10 Kbps
1	20 Kbps
2	50 Kbps
3	125 Kbps
4	250 Kbps
5	500 Kbps
6	800 Kbps
7	1 Mbit/s
8	Automatic detection
9	Default rate (250 Kbps)

NOTE:

- If the rate selected is incorrect, the OTB module generates a bus **OFF**.
- Position 8 is used to detect the bus transmission speed automatically. The search starts at 1 Mbit/s, then gradually reduces the baud rate in increments until communication is established on the bus. Automatic detection only works on an operational CANopen network with an active master.
- In automatic detection mode, at least one of the slaves present on the network must be configured with the same speed as the master.

For more information, refer to Advantys OTB CANopen, Remote Inputs and Outputs, User Manual, 1606384.

Section 5.3

Ethernet Network

What Is in This Section?

This section contains the following topics:

Topic	Page
Ethernet Network Topology	146
Ethernet Wiring	147
Magelis SCU HMI - Ethernet Wiring	149

Ethernet Network Topology

Ethernet Topology

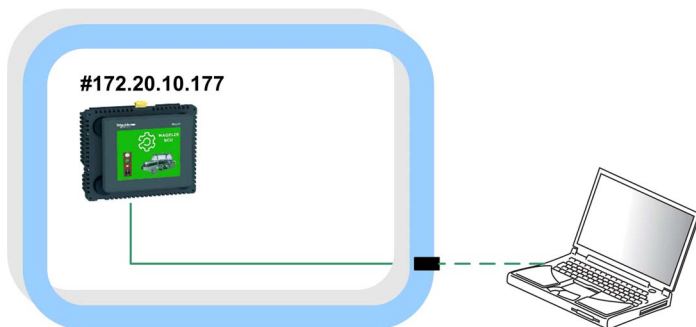

#... node address

The subnet mask is: 255.255.255.0.

In this architecture, the Ethernet connection is used for download and monitoring of the application only.

Ethernet Wiring

Overview Ethernet

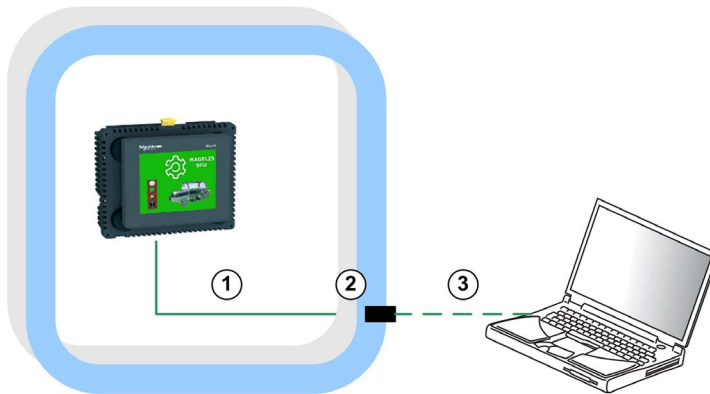

For more information, refer to Transparent Ready, User Guide, 31006929.

Wiring Accessories

N°	Reference	Designation	Description	Cable Length
1	490NTW00002	Ethernet ConneXium cable - shielded twisted-pair straight cord	one RJ45 connector at each end	2.0 m (6.56 ft)
	490NTW00005			5.0 m (16.40 ft)
2	TCSEAAF11F13F00	ConneXium M12 to RJ45 Ethernet adapter	adapter for panel mounting	-
3	TCSECL1M3M3S2	Ethernet ConneXium cable - shielded twisted pair	1 x IP 67, M12, 4-pin (D-coded) connector and 1 x RJ45 connector	3.0 m (9.84 ft)

ConneXium Ethernet Adapter

TCSECL1M3M3S2

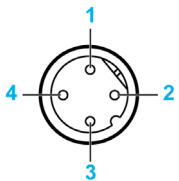
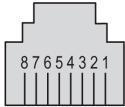

M12 Connector (D-Coded)	M12 Pin	Signal	Description	RJ45 Pin	RJ45 Connector
	1	TD+	transmit data +	1	
	2	RD+	received data +	3	
	3	TD-	transmit data -	2	
	4	RD-	received data -	6	
	-	-	no connection	4	
	-	-	no connection	5	
	-	-	no connection	7	
	-	-	no connection	8	

ConneXium Ethernet Cable

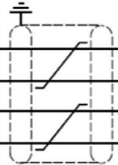

M12	Signal		Signal	RJ45
1	TD +			TD +
3	TD -		TD -	2
2	RD +		RD +	3
4	RD -		RD -	6

Magelis SCU HMI - Ethernet Wiring

Ethernet Port

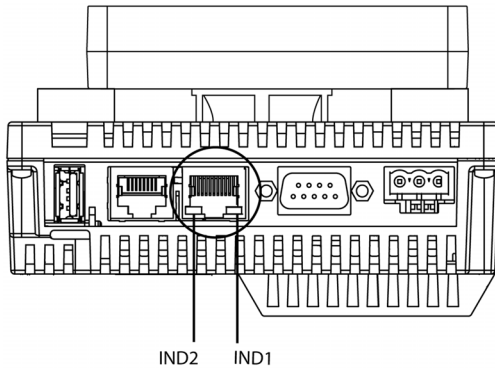

IND1 Ethernet activity LED
IND2 Ethernet status LED

The Magelis SCU HMI controller comes equipped with an IEEE802.3 compliant Ethernet interface that transmits and receives data at 10 Mbit/s or 100 Mbit/s.

Do not confuse the RJ45 Ethernet connector with the RJ45 serial port.

Characteristics	Description
Standard	Ethernet
Connector type	RJ45
Baud rate	Supports Ethernet "10BaseT" and "100BaseTX" with auto-negotiation
Auto-crossover	MDI / MDIX
Protocol supported	<ul style="list-style-type: none"> ● SoMachine protocol ● Modbus TCP/IP ● *
IP address negotiation type supported	<ul style="list-style-type: none"> ● Fixed IP ● DHCP
Power over Ethernet	No
* For more information about the supported protocols, refer to the Vijeo-Designer online help - Device driver manuals.	

For more information, refer to Magelis SCU HMI Controller, Hardware Manual, EIO0000001232.

Section 5.4

Modbus Serial Line Network

What Is in This Section?

This section contains the following topics:

Topic	Page
Modbus SL Network Topology	151
Modbus SL Wiring	152
Magelis SCU HMI - Modbus SL Wiring	153
iEM31xx Energy Meter - Modbus SL Wiring	155

Modbus SL Network Topology

Modbus SL Topology

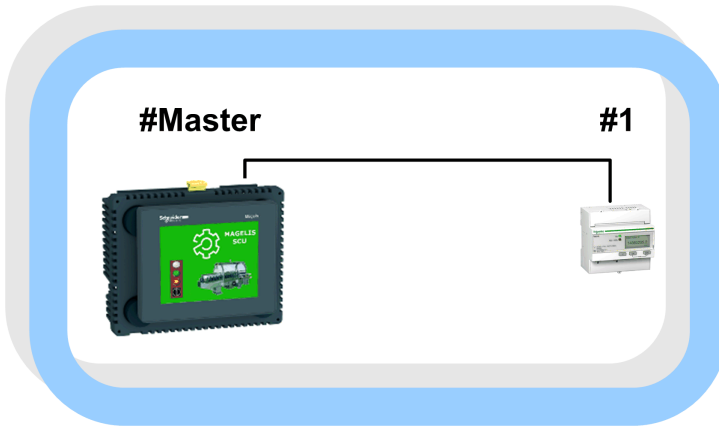

#... node address

Modbus SL Wiring

Modbus SL Overview

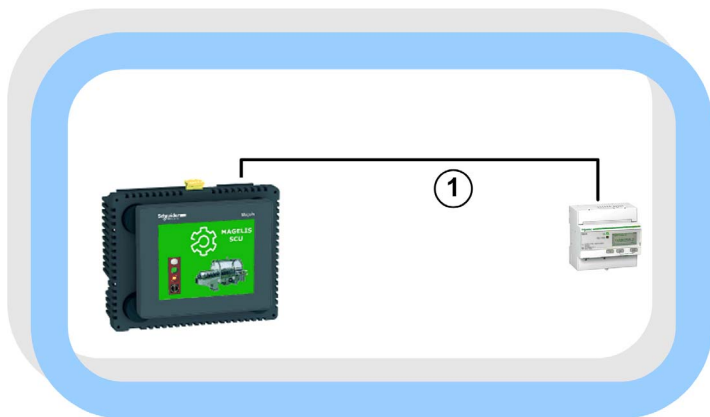

Cable

Reference	Designation	Description	Position	Cable Length
VW3A8306D30	Modbus SL drop cable	1 RJ45 connector and one end stripped	1	3.0 m (9.8 ft)

Magelis SCU HMI - Modbus SL Wiring

Serial Port Connector

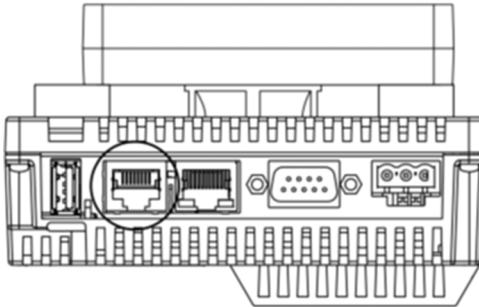

The isolated serial port allows the SCU HMI controller component to communicate with 2 protocols:

- SoMachine
- Modbus RTU

Pin Assignment

For this architecture, the port is configured as an RS-485.

Pins for RS-485 and RS-232

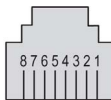

Pin	RS-232C	RS-485	Description
1	RxD	N.C.	Received data (RS-232C)
2	TxD	N.C.	Transmitted data (RS-232C)
3	N.C.	N.C.	No connection
4	N.C.	D1	Differential data (RS-485)
5	N.C.	D0	Differential data (RS-485)
6	RTS	RTS	Ready to send
7	N.C.	N.C.	No connection
8	GND	GND	Signal ground

 WARNING

UNINTENDED EQUIPMENT OPERATION

Do not connect wires to unused terminals and/or terminals indicated as “No Connection (N.C.)”.

Failure to follow these instructions can result in death, serious injury, or equipment damage.

Communication Settings

The Modbus SL port of the controller has to be configured within SoMachine.

- Baud rate: 19.2 kbps
- Parity: even
- Stop bit: 1
- Physical medium: RS-485 2-wire

Line Polarization

Line polarization is provided by the controller.

For more information, refer to :

- Magelis SCU HMI Controller, Hardware Manual, EIO0000001232.
- Magelis SCU, SoMachine, Programming Guide, EIO0000001240.

iEM31xx Energy Meter - Modbus SL Wiring

Modbus SL Port

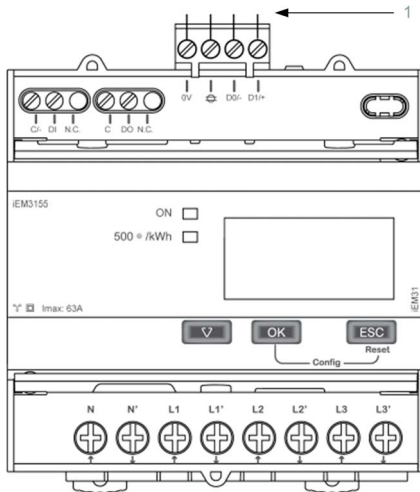

1 Modbus SL RS-485 2-wire port

For more information, refer to iEM3100 series / iEM3200 series, Energy Meters, User Manual, DOCA0005EN.

Pin Assignment

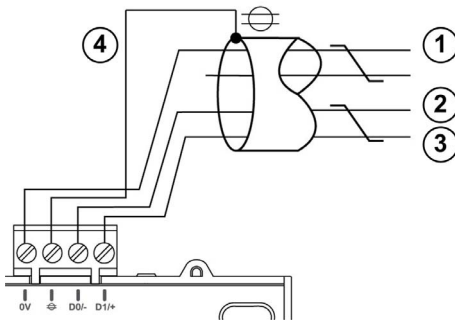

Item	Signal	Description
1	SNG	Modbus SL signal ground
2	D0	Modbus SL: D0 (-/A) RS-485 2-wire

Item	Signal	Description
3	D1	Modbus SL: D1 (+/B) RS-485 2-wire
4	SHLD	Modbus SL shield

Communication Settings

The Modbus SL port of the energy meter has to be configured via the local HMI on the front.

Chapter 6

Implementation

What Is in This Chapter?

This chapter contains the following sections:

Section	Topic	Page
6.1	Software Requirements	158
6.2	Access the SoMachine Project Template	159
6.3	Project	160

Section 6.1

Software Requirements

Software Requirements

Overview

The software required to open and to edit the project template is SoMachine V4.1 SP1 including the LXM28 add-on or later.

The following components must be installed together with SoMachine:

- SoMachine components
 - Logic Builder, including Logic Builder Lexium 28
 - Vijeo-Designer
 - Gateway
- Devices
 - Advantys (DTM)
 - Modbus (DTM)
- Repository
 - Optimized repository
- Documentation
 - Tested, Validated and Documented Architecture, including TVDA for Lexium 28
- Add-ons / patches
 - Add-on Lexium 28 for SoMachine V4.1 SP1

The SoMachine Configuration Manager, which is part of the SoMachine installation, allows you to verify the installation. In addition you can add, remove, or update components of your SoMachine installation.

Section 6.2

Access the SoMachine Project Template

Access the SoMachine Project Template

Overview

The SoMachine project related to the described architecture is available in terms of a project template.

It is tested and validated and includes the complete and executable application with program code and device configurations.

Also part of the SoMachine project is the Vijeo-Designer application which is ready to run on the defined Magelis panel for this architecture.

You can use the project template as basis for your own application.

Procedure

You can access the project template as described below.

Step	Action
1	Launch SoMachine. The Get started dialog box of SoMachine Central is displayed.
2	Click New . The New Project dialog box is displayed.
3	Click Templates . The New Project Assistant - Templates dialog box is displayed.
4	Enter a Project Name .
5	Select a template from the list.
6	Click the Create Project button. A new project based on the selected template is opened in SoMachine Logic Builder.
7	Now you can adapt (<i>see page 190</i>) your new project according to your requirements.

Section 6.3

Project

What Is in This Section?

This section contains the following topics:

Topic	Page
HMI Controller	161
Devices	163
Application	170
Vijeo-Designer	172

HMI Controller

Overview

The controller in this architecture is the HMISCUxA5, which is assigned to the category of HMI controller of Schneider Electric.

The mandatory settings for the controller are described below.

The parameter values depicted in this document relate to the template project and the test equipment used during development.

Serial Line

The serial line in this architecture is used for the communication between the controller and the energy meter.

Therefore, a Modbus manager has been added under the COM1 interface. To add the **Modbus Manager**, select the command **Add Device** from the context menu of the **COM1** node in the **Devices tree**. Select the **Modbus Manager** in the **Add Device** dialog box and click **Add Device**.

NOTE: Per default the SoMachine network manager is placed here, but this can be removed.

The serial line settings are performed in the device editor of the serial line interface. To open the device editor, double-click the **COM1** node in the **Devices tree**. The settings for this architecture are:

- Baud rate: 19200
- Parity: even
- Data bits: 8
- Stop bits: 1
- Physical medium: activate the check box labeled **RS-485**

The Modbus settings are performed in the device editor of the **Modbus Manager**. To open the device editor, double-click the **Modbus Manager** node in the **Devices tree**. The settings for this architecture are:

- Time between frames: 10 ms

For more information about the serial line configuration, refer to the document Magelis SCU, SoMachine, Programming Guide, EIO0000001240.

CANopen

This architecture includes a CANopen fieldbus which has to be configured in the project.

Therefore, the CANopen manager **CANopen_Optimized** has been added under the CAN interface. To add the CANopen manager, select the command **Add Device** from the context menu of the **CAN** node in the **Devices tree**. Select the device **CANopen Optimized** in the **Add Device** dialog box, and click **Add Device**.

The CANopen settings are performed in the device editor of the **CAN** interface. To open the device editor, double-click the **CAN** node in the **Devices tree**. The settings for this architecture are:

- **Baudrate (bits/s):** 500000
- Activate the check box labeled **Block SDO, DTM and NMT access while application is running**.

The settings for the CANopen manager are performed in the device editor of the **CANopen_Optimized** device. To open the device editor, double-click the **CANopen_Optimized** node in the **Devices tree**. The settings for this architecture are:

- Node ID: 127
- Heartbeat: Activate the check box **Enable Heartbeat Producing**.
 - Node ID: 127
 - Producer time: 200 ms
- Bus cycle options
 - Bus cycle task: MAST

For more information about the CANopen configuration, refer to the document Magelis SCU, SoMachine, Programming Guide, EIO0000001240.

Ethernet

The Ethernet network in this architecture can be used for a remote connection with the HMI controller.

The Ethernet settings of the Magelis SCU HMI Controller are accomplished with Vijeo-Designer. To open Vijeo-Designer, select **Vijeo Designer** from the **Quick Toolswitch** list of the SoMachine Central overlay bar (see SoMachine Central, User Guide (*see SoMachine Central, User Guide*)). In Vijeo-Designer, select **Network** in the target property editor and click the button ... to open the **Network Configuration** dialog box. Enter the Ethernet configuration as listed below and click **OK** to apply your settings.

- IP address: 172.20.10.177
- Subnet mask: 255.255.0.0

For the other parameters, the default settings have been used for the present template.

The Ethernet configuration becomes effective after a download of the application to the HMI controller.

Devices

Overview

In this chapter, the devices configured within the SoMachine project are described.

Energy Meter iEM3150

The architecture implements 1 energy meter of type iEM3150 for energy measurement. The energy data are read from the device via Modbus serial line.

The device itself is not configured in the application. The Modbus communication is realized by system functions as part of the function block `FB_PowerMeter` out of the **ModbusEnergyEfficiencyToolbox** library.

The program code to read and to process the data of the power meter was created in the application by adding the Device Module `MED_iEM3150_ModbusSL` which is represented as a function template within the **TVDA Device Module Library** ([see page 193](#)).

The only configuration is the assignment of the slave address and the network ID to the associated variables (CONSTANTS) within the **Add Function From Template** dialog box.

Altivar 32

The architecture implements 2 variable speed drives of type Altivar 32 which are controlled via CANopen.

These devices must be configured within the SoMachine project.

Therefore, the devices were added under the CANopen manager **CANopen Optimized**.

Each device was added with the use of the Device Module `ATV32_CANopen`, which is represented as a function template within the **TVDA Device Module Library** ([see page 193](#)).

The name of each device corresponds with the name which was assigned within the **Add Function From Template** dialog box.

The devices are preconfigured, so the only configuration is the selection of the node ID within the **Add Function From Template** dialog box.

The following devices were added under the CANopen manager of the CAN interface:

Device name	Node ID configuration
ATV32_Node01	1
ATV32_Node02	2

Lexium 28

The architecture implements 2 servo drives of type Lexium 28 which are controlled via CANopen. These devices must be configured within the SoMachine project.

Therefore, the devices were added under the CANopen manager **CANopen Optimized**.

Each device was added with the use of the Device Module Lexium_28_CANopen, which is represented as a function template within the **TVDA Device Module Library** (see page 193).

The name of each device corresponds with the name which was assigned within the **Add Function From Template** dialog box.

The devices are preconfigured, so the only configuration is the selection of the node ID within the **Add Function From Template** dialog box.

The following devices were added under the CANopen manager of the CAN interface:

Device name	Node ID configuration
LXM28_Node03	03
LXM28_Node04	04

NOTE: The device provided with the Device Module Lexium_28_CANopen differs to the standard device **Lexium 28** provided with SoMachine device repository. The device in this example uses the second and third transmit PDO (TPDO). The present position value (second TPDO) and the present velocity value (third TPDO) of the drive are transmitted in an event driven way. The event time for these TPDOs is set per default to 100 ms. In addition, the inhibit time for both TPDOs is set to 10 ms. These additional PDOs increase the bus load. Consider this fact for your own application.

For more information about the PDO configuration, refer to the SoMachine online help **Programming with SoMachine** → **Device Editors** → **CANbus Configuration Editor** → **CANopen Device** → **PDO Mapping**.

TeSys U

The architecture implements 1 motor starter controller of type TeSys U which is controlled via CANopen.

The TeSys U is equipped with a standard control unit. This device must be configured within the SoMachine project.

Therefore, the device was added under the CANopen manager **CANopen Optimized**.

The device was added with the use of the Device Module TeSysU_CANopen_Standard, which is represented as a function template within the **TVDA Device Module Library** (see page 193).

The name of the device corresponds with the name which was assigned within the **Add Function From Template** dialog box.

The device is preconfigured, so the only configuration is the selection of the node ID within the **Add Function From Template** dialog box.

The following device was added under the CANopen manager of the CAN interface:

Device name	Node ID configuration
TeSysU_CANopen05	05

Lexium 32i

The architecture implements 1 integrated servo drive of type Lexium 32i which is controlled via CANopen.

This device must be configured within the SoMachine project.

Therefore, the device was added under the CANopen manager **CANopen Optimized**.

The device was added with the use of the Device Module Lexium_32i_CANopen, which is represented as a function template within the **TVDA Device Module Library** ([see page 193](#)).

The name of the device corresponds with the name which was assigned within the **Add Function From Template** dialog box.

The device is preconfigured, so the only configuration is the selection of the node ID within the **Add Function From Template** dialog box.

The following device was added under the CANopen manager of the CAN0 interface:

Device name	Node IC configuration
LXM32i_CANopen06	11

NOTE: The device provided with the Device Module Lexium_32i_CANopen differs to the standard device Lexium 32i provided with SoMachine device repository. The device in this example uses the second and third transmit PDO (TPDO). The present position value (second TPDO) and the present velocity value (third TPDO) of the drive are transmitted in an event driven way. The event time for these TPDOs is set per default to 100 ms; in addition, the inhibit time for both TPDOs is set to 10 ms. These additional PDOs increase the bus load.

For more information, refer to the SoMachine online help **Programming with SoMachine** → **Device Editors** → **CAN bus Configuration Editor** → **CANopen Device** → **PDO Mapping**.

After the device has been added, an additional configuration via SDO (Service Data Object) has been done within the **Device Editor** tab. In this example application, an SDO has been added to deactivate the input monitoring of the drive.

Service data object added:

Index:Subindex	Name	Value	Comment
16#3006:16#10	Motion global.IOsигLIMP	0	Deactivates the monitoring input for positive limit switch
16#3006:16#0F	Motion global.IOsигLIMN	0	Deactivates the monitoring input for negative limit switch

NOTE: The monitoring inputs have been disabled because the drive is applied in modulo motion mode (endless movements). If your application requires the end of travel limits, then set the value for `Settings.SignEnabl` to your needs or respectively delete this SDO from the list and make the configuration via another channel.

For more information about the SDO configuration, refer to the documents:

- SoMachine online help **Programming with SoMachine** → **Device Editors** → **CANbus Configuration Editor** → **CANopen Device** → **Service Data Object**
- LXM32iCAN BMi, Lexium 32 Integrated, Product manual, 0198441113950 (ENG)

Modicon OTB

The architecture implements a Modicon OTB distributed I/O island which is linked to the CANopen fieldbus.

This I/O island must be configured within the SoMachine project.

The table describes the steps to create and configure the I/O island in the SoMachine project:

Step	Action	Comment
1	Select the command Add Device from the context menu of the CANopen_Optimized node in the Devices tree .	The Add Device dialog box opens and the compatible devices for adding are listed. NOTE: The option Vendor must be set to Schneider Electric (default).
2	Double-click the device OTB 1C0DM9LP Advanced Settings in the Add Device dialog box.	The OTB CANopen interface module is added to the Devices tree .
3	Close the Add Device dialog box.	–
4	Double-click the OTB_1C0DM9LP node in the Devices tree .	The device editor opens.
5	Configure the CANopen node ID for the OTB.	In the device editor tab DTM Information , enter the CANopen address in accordance to the address settings on the device.
6	Start the Advantys tool to configure the OTB I/O island.	In the device editor tab Configuration , click the button Start Advantys . The Advantys configuration tool is open in a new window.

Step	Action	Comment
7	Drag the desired modules from the Catalog Browser on the right side and drop them on the depicted rail in the Island Editor in the middle of the workspace.	The following modules are configured in this architecture: <ol style="list-style-type: none"> 1. OTB 1C0DM9LP (CANopen network interface module) 2. OTB TM2DDI16DT (digital input module) 3. OTB TM2DDI16DT (digital input module) 4. OTB TM2DRA16RT (digital output module) 5. OTB TM2DDO8TT (digital output module) 6. OTB TM2AMI4LT (analog input module) 7. OTB TM2ALM3LT (analog I/O module)
8	Each module provides an individual configuration if the default settings do not meet the requirements of your application. The configuration needs to be performed in the Advantys tool. In this architecture, additional configurations have been performed only for the analog modules. The other modules are used with their default settings.	
9	Double-click the module OTB TM2AMI4LT in the island editor.	The Module Editor dialog box opens.
10	Configure the input channels of the module in the tab Parameters of the Module Editor dialog box.	In this architecture, the settings for each analog input are: <ul style="list-style-type: none"> ● Mode: PT100 ● Range: 0.1° C (32.18° F) For the other parameters, the default values are used for the present template.
11	Close the Module Editor dialog box.	–
12	Double-click the module OTB TM2ALM3LT in the island editor.	The Module Editor dialog box opens.
13	Configure the I/O channels of the module in the tab Parameters of the Module Editor dialog box.	In this architecture, the settings for the analog I/Os are: Inputs <ul style="list-style-type: none"> ● Mode: PT100 ● Range: 0.1° C (32.18° F) Outputs <ul style="list-style-type: none"> ● Mode: 0...10V ● Range: Custom ● Max: 1000 For the other parameters, the default values are used for the present template.

Step	Action	Comment
14	Close the Module Editor dialog box.	–
15	Select the command Save Workspace from the toolbar File and close the Advantys tool.	The configuration of the I/O island is transferred to the SoMachine application. The Advantys tool is closed and the island configuration is depicted in the device editor in SoMachine.
16	In the device editor tab Configuration , click the button Apply .	The configurations performed with the Advantys tool are applied to the device OTB_1C0DM9LP in SoMachine. The content of the tabs CANopen Configuration and CANopen I/O Mapping are updated.

For more information about the configuration of an OTB distributed I/O island, refer to the Device Type Manager (DTM) - User Guide (see *SoMachine, Device Type Manager (DTM), User Guide*).

Biometric USB Switch

The architecture implements a Harmony biometric USB switch which is connected via USB to the HMI SCU. The biometric USB switch is the Schneider Electric XB5S external hardware device that allows you to log in to a target machine by scanning fingerprints, with or without providing user names and passwords.

For example, at build time you can set a security user group authentication to either password or fingerprint. To log in to the target machine at run time, members of this security user group can use the system login panel and provide their user names and passwords, or they can scan their fingers on the biometric switch.

To use the biometric USB switch, it must be configured within the Vijeo-Designer application.

Step	Action	Comment
1	Add the biometric USB switch to the I/O manager.	<ul style="list-style-type: none"> ● In the Project tab of the Navigator window, right-click the I/O Manager and select New Driver. ● In the New Driver dialog box, select Schneider Electric USB Accessories. ● Select XB5S5 Biometric Switch and click OK.
2	Create a new user group or adapt an existing.	<ul style="list-style-type: none"> ● In the Project tab of the Navigator window, right-click Security and select New Group.
3	Set up the user group authentication.	<ul style="list-style-type: none"> ● In the Security Editor, click the Password/Fingerprints cell to expand the list. ● Select Either for user authentication by name and password or fingerprints.

Step	Action	Comment
4	Create a new user in the group of step 3 or adapt an existing.	<ul style="list-style-type: none"> ● In the Project tab of the Navigator window, right-click Security and select New User. ● Select the security group which the user should belong to. ● Select the user name and the password. ● Enable the check box Use Fingerprints.
5	Capture the fingerprints of the user using the connected biometric USB switch to your PC.	<ul style="list-style-type: none"> ● The biometric USB switch requires an external 24 Vdc power supply. ● Connect the biometric USB switch to an USB port of your PC. ● Follow the instructions in the opened window of step 5.
6	Connect the biometric USB switch to the USB port of the target.	The biometric USB switch requires an external 24 Vdc power supply.
7	Download the project to the target using Vijeo-Designer or SoMachine.	At run time, the target machine detects the connected biometric switch, verifies, and updates its content.

NOTE: Adding users to a security group with authentication by fingerprints is not possible at run time. The recording of fingerprints can be managed only using the Vijeo-Designer software with a biometric USB switch linked to the PC.

For more information, refer to the Vijeo-Designer online help

Application

Library Manager

The library manager is a standard object of the application.

Within the library manager, you can add or remove libraries.

In this example application, the Schneider Electric Toolbox library has been added manually. The other libraries were loaded automatically on adding devices or Device Modules.

Symbol Configuration

The symbol configuration functionality allows to create symbol descriptions, via which project variables can be accessed from external, for example when exchanging variables with HMI application via Vijeo-Designer or via OPC server. The variables for control and monitor functions on the Magelis HMI were published within the symbol configuration editor. By publishing the variables in SoMachine, they will automatically be available for use in the Vijeo-Designer HMI application as SoMachine variables. For the manual export of the variables, use the command **Export Variables to Vijeo Designer** from the context menu of the **Symbol Configuration** in the **Tools tree**.

For more information, refer to the following chapters of the SoMachine Programming Guide:

- Symbol Configuration Editor (see *SoMachine, Programming Guide*)
- SoMachine Controller - HMI Data Exchange (see *SoMachine, Programming Guide*)

Task Configuration

The **Task Configuration** defines one or several tasks for controlling the processing of an application program.

Thus it is a basic resource object for an application and is automatically added to the application node.

In this example application 1 task is configured:

Task	Type	Comment
MAST	Cyclic: 20 ms	This task includes the program calls related to the motor control devices, Modbus communication and general application code.

For more information, refer to Task Configuration Editor (see *SoMachine, Programming Guide*).

Program Code

The program code is divided into several POUs (Program Organization Units) of type program and GVLs (Global Variable Lists).

Each POU is called separately within the associated task.

The POUs and GVLs which are related to the devices or functional units were created on adding the Device Modules. Hence, they are placed in folders (with the corresponding names) under the **Application** node.

The following folders including the respective POUs and GVLs are available:

- ATV32_Node01
- ATV32_Node02
- LXM32i_Node11
- TeSysU_Node05
- iEM3150_MdbSL
- LXM28_Node03
- LXM28_Node04

For the general programming part, additional POUs are available. In these POUs, the processing of HMI commands, a summary of information about devices, the communication state, and state of the safety functions is realized in relation to the different functional units of the application. The following POUs are available:

- **Preprocessing**
Processing of command signals for the devices (for example, operator push buttons, HMI commands, and so on).
- **MAIN**
Processing of summary information about device and communication state.
- **AlarmManager**
Processing of alarm management of the architecture.
- **OutputMapping**
Processing of output signals for tower light, operator push-button lighting, and analog outputs.

Vijeo-Designer

Overview

The HMI application is created with the configuration software Vijeo-Designer, which is integrated in SoMachine.

This architecture uses the integrated HMI component of the Magelis SCU HMI Controller to run the HMI application.

The application is executed on this panel and provides extensive monitoring and control functions of the architecture.

Start Page

The start page provides general information about the state of the architecture:

- Device state
- Communication state
- Safety state

Alarm Page

The alarm page provides detailed alarm messages sorted by time of occurrence.

CANopen Overview Page

The CANopen overview provides information about the fieldbus topology and the state of CANopen devices.

Application Control Page

The application control page provides the possibility to run and stop the application.

User Management Page

On the user management page user profiles are managed.

This page is protected and can only be accessed by authorized users.

Energy Pages

The energy pages provide information about the energy data of the architecture.

Device Pages

The device pages provide monitor and control functions for each device grouped by products:

- Altivar
- TeSys U
- Lexium
- I/Os

Chapter 7

System Setup

Overview

This chapter describes the steps necessary to set the architecture in operational mode. It is not intended to replace any specific product documentations or manuals.

The setup procedure depicted in this document is relevant only for the proposed architecture.

Before using any device in this application, perform the following steps:

- Thoroughly read this manual and the respective related documents before running this application.
- Install the drives according to their usage and configure the connected motors.
- Thoroughly verify your installation.
- Set up the communication parameters of the devices.

WARNING

LOSS OF CONTROL

- The designer of any control scheme must consider the potential failure modes of control paths and, for certain critical control functions, provide a means to achieve a safe state during and after a path failure. Examples of critical control functions are emergency stop and overtravel stop, power outage and restart.
- Separate or redundant control paths must be provided for critical control functions.
- System control paths may include communication links. Consideration must be given to the implications of unanticipated transmission delays or failures of the link.
- Observe all accident prevention regulations and local safety guidelines.¹
- Each implementation of this equipment must be individually and thoroughly tested for proper operation before being placed into service.

Failure to follow these instructions can result in death, serious injury, or equipment damage.

¹ For additional information, refer to NEMA ICS 1.1 (latest edition), "Safety Guidelines for the Application, Installation, and Maintenance of Solid State Control" and to NEMA ICS 7.1 (latest edition), "Safety Standards for Construction and Guide for Selection, Installation and Operation of Adjustable-Speed Drive Systems" or their equivalent governing your particular location.

What Is in This Chapter?

This chapter contains the following sections:

Section	Topic	Page
7.1	Setup Controller and HMI	175
7.2	Setup Other Devices	177

Section 7.1

Setup Controller and HMI

Setup Controller and HMI

Overview

You must download the applications from the PC to the HMI controller to run the applications.

There are several possibilities to perform the application download:

- Via an USB cable (linked to the integrated mini USB port of the HMI controller)
- With an USB memory key (linked to the integrated USB port of the HMI controller)
- Via an Ethernet connection (linked to the Ethernet network)

By using a USB connection or an Ethernet connection between HMI controller and PC, additional features like monitoring of the application in online mode are available.

NOTE: SoMachine V4.1 and the associated Vijeo-Designer configuration software are required on the PC.

Download Procedure

For the download procedure described in this section, an USB connection between PC and controller is used.

To set up a communication between an HMI controller and a PC via USB, use one of the following cables:

- TCSXCNAMUM3P
- BMXXCAUSBH045

Using the established USB connection between PC and HMI controller, proceed as follows to download the SoMachine and HMI application.

The table describes the download procedure of the SoMachine application and the HMI application using the SoMachine software.

Step	Action	Comment
1	Double-click the controller.	The controller device editor opens.
2	Select the Controller selection tab.	The compatible controllers connected to the PC are listed.
3	Double-click the list entry to select the HMI controller.	The selected controller is displayed in bold and the address is displayed at the bottom of the device editor.

Step	Action	Comment
4	Click Online → Multiple Download... to download the applications.	The Multiple Download dialog box opens. You can choose which application should be downloaded. If the application can be stopped during the download, a full download is recommended. Using the Additional operations a start of all applications after download can be performed.

NOTE: The firmware/runtime version of the HMI controller has to correspond with the version of the HMI controller in the SoMachine project. If the firmware/runtime versions of the devices mismatch, you have to upgrade the version of the HMI controller. As a standard feature the runtime is updated during the initial download of the HMI application, but optional you can perform a runtime update using the Vijeo-Designer **Runtime Installer**.

The **Runtime Installer** is accessible via the tool access bar (see *SoMachine Central, User Guide*) in SoMachine Central (**Tool Access Bar** → **Maintenance** → **Download Firmware HMI**).

Section 7.2

Setup Other Devices

What Is in This Section?

This section contains the following topics:

Topic	Page
Network and Device Parameter Settings	178
TeSys U Motor Starter - CANopen Setup	179
Altivar 32 Variable Speed Drive - CANopen Setup	180
Lexium 28 Servo Drive - CANopen Setup	183
Lexium 32i Servo Drive - CANopen Setup	185
iEM3150 Energy Meter - Modbus SL Setup	186

Network and Device Parameter Settings

Overview

This section describes the steps required to initialize and configure the different devices required to attain the described system function.

The following devices are configured by using the local control panel on the device itself:

- Lexium 28
- Altivar 32
- iEM3150 energy meter

NOTE: If a device has already been configured for some other use, re-establish the factory settings. Instructions on how to do this can be found in the respective documentation.

NOTE: Be sure that the controller is in a STOP state before parameterizing the drives.

WARNING

UNINTENDED EQUIPMENT OPERATION

- Never assume that your controller is in a certain controller state before commanding a change of state, configuring your controller options, uploading a program, or modifying the physical configuration of the controller and its connected equipment.
- Before performing any of these operations, consider the effect on all connected equipment.
- Before acting on a controller, always positively confirm the controller state by viewing its LEDs, confirming the condition of the Run/Stop input (if so configured) and/or the Run/Stop switch (if so equipped), verifying the presence of output forcing, and reviewing the controller status information via SoMachine ⁽¹⁾.

Failure to follow these instructions can result in death, serious injury, or equipment damage.

⁽¹⁾ The controller states can be read in the `HMISCU_PLC.PLC_R.i_wStatus` system variable of the Magelis SCU SoMachine PLCSystem Library.

For setting the communication parameters of the following devices, refer to the respective sections in the *Communication* chapter:

- Modicon OTB - CANopen Wiring ([see page 142](#))

TeSys U Motor Starter - CANopen Setup

Overview

The setup of the TeSys U motor starter includes 2 steps.

- The communication settings will be done by the dip switches located on the communication module LULC08 and is described in the communication chapter ([see page 133](#)).
- The thermal protection of the motor is set by the rotary switch on the front of the control unit LUCA05BL. The set value has to be appropriate for the connected motor.

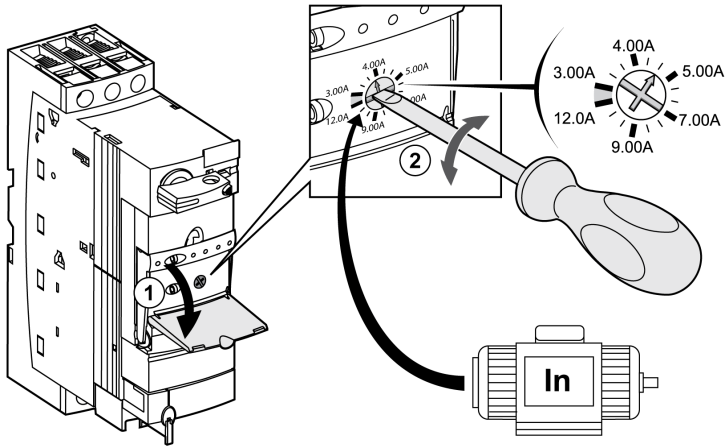

Altivar 32 Variable Speed Drive - CANopen Setup

Overview

To operate the Altivar 32 via CANopen fieldbus, the communication parameters have to be set for the device. In addition to this, it is mandatory to set the parameter of the connected motor in the drive. Further configuration settings are dependent on your application and on the installation.

There are several options to configure the drive:

- by the local HMI on the front of the drive
- by a graphic display terminal*
- by a remote display terminal*
- by the configuration software SoMove installed on a PC*
- by the FDT/DTM integrated in SoMachine installed on a PC*
- by the software SoMove Mobile installed on a mobile phone linked via Bluetooth

(* linked to the integrated communication port on the front of the drive)

WARNING

UNINTENDED EQUIPMENT OPERATION

- Verify that both wiring and mounting are correct before you start to configure the drive.
- Verify that an unintentional start of the connected motor will not endanger personnel or equipment in any way.

Failure to follow these instructions can result in death, serious injury, or equipment damage.

If necessary, disconnect the motor from the drive to prevent an unintentional motor start.

Configuration

NOTE: The parameter or menu items which are mentioned within the table could be located under unmentioned menu items. This is dependent to the method of configuration.

Step	Action	Comment
1	Switch on the power supply.	Do not give a run command to the drive.
2	Configure the motor parameters under the menu [Motor Control] (drc-): <ul style="list-style-type: none"> • [Standard mot. freq] (bFr) • [Max frequency] (tFr) • [Motor control type] (Ctt) 	Refer to the motor rating plate. Values have to be adjusted if the factory settings differ with your application. If the drive shall apply the brake control logic, the parameter [Motor control type] (Ctt) has to be set either to [SVC V] (UUC) or [Energy sav.] (nLd).

Step	Action	Comment
3	Configure the motor parameters under the menu [ASYNC. Motor] (ASY-): <ul style="list-style-type: none"> • [Rated motor power] (nPr) • [Motor 1 Cosinus Phi] (COS) • [Rated motor volt.] (UnS) • [Rated motor current] (nCr) • [Rated motor freq.] (FrS) • [Rated motor speed] (nSP) 	Refer to the motor rating plate. Values have to be adjusted if the factory settings differ with your application.
4	Configure the parameters under the menu [SETTINGS] (Set-): <ul style="list-style-type: none"> • [Acceleration] (ACC) • [Deceleration] (dEC) • [Low Speed] (LSP) • [High Speed] (HSP) • [Mot. Therm. current] (ItH) 	In most cases, the factory settings can be maintained for a quick start. But nevertheless, you have to verify the values.
5	Configure the I/O assignment under the menu [INPUTS/OUTPUTS CFG] (I_o-).	The I/O configuration depends on your architecture and the activated application functions of the drive. In most cases, the factory settings can be maintained for a quick start. But nevertheless, you have to verify the values.
6	Configure the command channel under the menu [COMMAND] (Ct1-): <ul style="list-style-type: none"> • [Ref. 1 channel] (Fr1) 	If the drive is operated via CANopen fieldbus, the parameter [Ref. 1 channel] (Fr1) has to be set either to [CANopen] (CAn) or [Com.card] (net). This depends on the used communication port.
7	Configure the communication parameter under the menu [COMMUNICATION] (COM-): <ul style="list-style-type: none"> • [CANopen] (CnO-) <ul style="list-style-type: none"> • [CANopen address] (AdCO) • [CANopen bit rate] (bdCO) 	The communication parameter for the CANopen network is dependent on your architecture and the settings of the CANopen master which is usually the controller.
8	Set the access level to enable further application functions under the menu [ACCESS LEVEL] (LAC)	To enable the settings for the brake control logic, the parameter [ACCESS LEVEL] (LAC) has to be set to [Expert] (EPr).
9	Configure the parameter for the brake control under the menu [BRAKE LOGIC CONTROL] (bLC-): <ul style="list-style-type: none"> • [Brake assignment] (bLC) 	By the parameter [Brake assignment] (bLC) you select the logic output or control relay to control the contactor to release the electro magnetic brake on the motor. Further parameter can be set dependent to your application.
10	Power cycle the drive.	If the configuration is finished, do a power cycle of the drive, because some parameters only become effective after a power cycle.

 **WARNING**

UNINTENDED EQUIPMENT OPERATION

Power cycle the drive after any configuration changes or adjustments (power removal followed by power reapplied).

Failure to follow these instructions can result in death, serious injury, or equipment damage.

Lexium 28 Servo Drive - CANopen Setup

Overview

To operate the Lexium 28 via CANopen fieldbus, the communication parameters have to be set for the device. Further configuration settings are dependent on your application and on the installation.

There are several options to configure the drive:

- By the local HMI on the front of the drive
- By the configuration software SoMove installed on a PC*
- By the FDT/DTM as part of the SoMachine software installed on a PC*

(*linked to the commissioning interface CN3 on the front of the drive)

NOTE: If a device has already been configured for some other use, re-establish the factory settings. Instructions on how to do this can be found in the respective documentation.

WARNING

UNINTENDED EQUIPMENT OPERATION

- Verify that both wiring and mounting are correct before you start to configure the drive.
- Verify that an unintentional start of the connected motor will not endanger personnel or equipment in any way.

Failure to follow these instructions can result in death, serious injury, or equipment damage.

I/O Assignment

In this example, the default configuration of digital inputs and outputs for CANopen control mode is used. The table lists the configuration:

Signal	Control terminal Lexium 28	Description
Reference Home sensor	DI5	Reference sensor for the homing operation.
Negative inhibit limit switch	DI6	If FALSE drive is stopped immediately with alert AL014 .
Positive inhibit limit switch	DI7	If FALSE drive is stopped immediately with alert AL015 .
Operation stop	DI8	If FALSE drive is stopped immediately with alert AL013 .
Servo is ready	DO1	Indicates if the servo drive is ready for operation.
Alarm detected	DO5	Indicates the error detection status of the drive.

Configuration

To adjust the parameters, use the following path and values

Step	Action	Comment
1	Configure the control mode and the output direction with parameter [P1-01].	In this example, the parameter [P1-01] is set to 110B hex. The meaning of the digits from right to the left is: 0B: CANopen control mode 1: Output direction (motor), positive = clockwise 1: Digital I/O settings ([P2-10]...[P2-22]) are changed to their default values after a power cycle.
2	Power cycle the drive.	In order to restore the default values for the I/O settings if selected in step 1 (P1-01).
3	Configure the CAN baud rate [P3-01].	In this example, the parameter [P3-01] is set to 0202 hex. The meaning of the digits from right to the left is: 2: RS-485 baud rate, 19.2 kbps 0: Reserved 2: CAN baud rate, 500 kbps 0: Reserved
4	Configure the CAN address [P3-05].	Every device in the CAN network has a unique address/node ID between 1 and 127.
5	Configure the digital input functions: <ul style="list-style-type: none"> ● [P2-10] ... [P2-17] for the inputs ● [P2-18] ... [P2-22] for the outputs 	In this example, the default configuration for the digital inputs and outputs for CANopen control mode is used.
6	Power cycle the drive.	If the configuration is finished, perform a power cycle of the drive. Some parameters only become effective after a power cycle.

WARNING

UNINTENDED EQUIPMENT OPERATION

Power cycle the drive after any configuration changes or adjustments (power removal followed by power reapplied).

Failure to follow these instructions can result in death, serious injury, or equipment damage.

After the configuration, an additional commissioning procedure needs to be performed, for example, a tuning of the drive system and the scaling of the axis.

For more information, refer to LXM28A and BCH2, Servo drive system, Product manual, 0198441114054-EN.

Lexium 32i Servo Drive - CANopen Setup

Overview

To operate the Lexium 32i via CANopen fieldbus, the communication parameters have to be set for the device. Further configuration settings depend on your application.

There are several options to configure the communication parameter of the drive:

- by the switches on the drive
- by the configuration software SoMove installed on a PC*

(* linked to the integrated communication port CN10) below the cover of the commissioning interface of the drive (*see page 139*).

NOTE: If a device has already been configured for some other use, re-establish the factory settings. Instructions on how to do this can be found in the respective documentation.

WARNING

UNINTENDED EQUIPMENT OPERATION

- Verify that both wiring and mounting are correct before you start to configure the drive.
- Verify that an unintentional start of the connected motor will not endanger personnel or equipment in any way.

Failure to follow these instructions can result in death, serious injury, or equipment damage.

If necessary, disconnect the motor from the drive to prevent an unintentional motor start.

Communication Settings

Address

The device address can be set directly with the DIP switches (*see page 140*). If all DIP switches are set to 0 (default), the address has to be set via the parameter `CANaddress` using the commissioning software.

Refer to Commissioning Interface and Address Setting (*see page 140*).

Baud rate

The baud rate can be set directly with the DIP switches (*see page 140*). If the DIP switches are set in a specific combination (default), the baud rate has to be set via the parameter `CANbaud` using the commissioning software.

Refer to Commissioning Interface and Baud Rate (*see page 141*).

Also refer to LXM32iCAN BMi, Lexium 32 Integrated, Product manual, 0198441113950 (ENG).

iEM3150 Energy Meter - Modbus SL Setup

Overview

The energy meter features a sophisticated and intuitive human machine interface (HMI) with signaling LEDs, a graphic display, and contextual menu buttons for accessing the information required to operate the energy meter and modify parameter settings. The navigation menu allows displaying, configuring, and resetting parameters.

The graphic shows the general display:

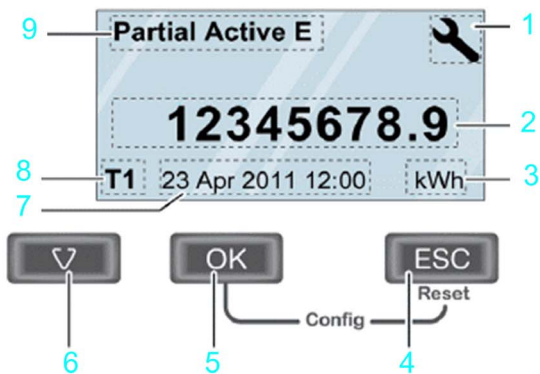

- 1 configuration mode
- 2 values / parameters
- 3 unit
- 4 cancellation
- 5 confirmation
- 6 selection
- 7 date and time (except for iEM3100 / iEM3200)
- 8 Active tariff (iEM3115 / iEM3155 / iEM3215 / iEM3255)
- 9 functions / measurements

In addition to this system user guide the product manual for the iEM3150 energy meter has to be read carefully.

For more information, refer to iEM3100 series / iEM3200 series, Energy Meters, User Manual, DOCA0005EN.

Configuration

Before starting the configuration of the energy meter, verify and ensure that your equipment is properly installed and the application functions correctly:

Step	Action	Comment
1	Set date and time.	When the power is interrupted, the iEM3150 automatically resets the date and time. The start screen after power-on prompts you to set the date and time.
2	Enter the configuration mode. Press and hold ESC + OK for at least 2 seconds.	The display switches to configuration mode.
3	Select the submenu Wiring and set the parameter for it.	The default wiring parameter is set to 3PH4W.
4	Select the submenu Frequency and set the parameter for it.	The default frequency parameter is set to 50 Hz.
5	Select the submenu Communication and set the slave address, baud rate, and parity for it.	The default values of the parameters are set to: <ul style="list-style-type: none"> ● slave address = 1 ● baud rate = 19200 ● parity = even
6	Leave the setup menu by pressing ESC .	–

NOTE: Further configuration can be done depending on your application needs. For more information, refer to iEM3100 series / iEM3200 series, Energy Meters, User Manual, DOCA0005EN.

Chapter 8

Adapt TVDA Template

What Is in This Chapter?

This chapter contains the following sections:

Section	Topic	Page
8.1	Adapt SoMachine Project Template	190
8.2	Adapt HMI Application	197

Section 8.1

Adapt SoMachine Project Template

What Is in This Section?

This section contains the following topics:

Topic	Page
Introduction	191
Device Modules in General	192
Device Modules Used in This Project Template	193
Add Device Modules	194
Remove Device Module	196

Introduction

Overview

The structure of a TVDA project template has a modular design which is based on Device Module (*see page 192*).

This allows you to create your customized project in an easy and flexible way by adapting the TVDA project template.

- Add Device Modules (*see page 194*)
- Remove Device Modules (*see page 196*)

Device Modules in General

Overview

The Device Modules out of the **TVDA Device Module Library** are represented by Function Templates (see *SoMachine, Programming Guide*) within SoMachine. They are especially created for the TVDA project template.

Device Modules are available for all functional units implemented in the different TVD architectures.

By definition functional units in the extent of Device Modules are all sorts of field devices controlled (connected) in various ways by the controller.

All required SoMachine application content, beginning with integrating the device to the hardware configuration up to integration of all needed program code is provided.

Each Device Module comes with its own global variable definition and helps to ensure consistency within the application.

During the device module insertion process, the software prompts you to assign the required configuration such as addresses, names, variable assignment to I/Os, and parameter assignment. (Refer to Add Device Module ([see page 194](#)).

Each Device Module provides a ready to use interface within the application program to control the device and to monitor its status.

Device Modules Used in This Project Template

Used Device Modules

The following Device Modules of the **TVDA Device Module Library** are used in this project template.

Device Module
ATV32_CANopen
Lexium_28_CANopen
Lexium_32i_CANopen
MED_iEM3150_ModbusSL
TeSysU_CANopen_Standard

Refer to TVDA Device Module Library (see *TVDA Device Module Library, Function Template Library Guide*).

Add Device Modules

Procedure

To add a Device Module, proceed as follows:

Step	Action
1	Right-click the Application node in the Tools tree and select Add Function From Template from the context menu. The Add Function From Template dialog box is displayed.
2	Enter a Function Name that is used for the new folder of the Device Module and for the naming of the elements it contains (GVL, POU, POU call, device, and so on).
3	Click the ... button and select a Device Module (Function Template) from the TVDA Device Module Library . Confirm with OK .
4	Now you can edit the different properties. Which properties can be edited depends on the selected Device Module.
5	For some Device Modules, it is possible to configure the device addresses. In Address column of the I/O Devices field, click the ... button to open the Select Device Address dialog box and select a free address. (Free addresses are displayed in black and can be selected. Already applied addresses are grayed/disabled).
6	In Master column of the I/O Devices field, click the ... button to open the Select Fieldbus Master dialog box and select the fieldbus master for your Device Module. Confirm with OK . If an appropriate fieldbus master is available, it is preselected in the dialog box.
7	The I/O Mapping field is an optional feature and not mandatory. For some Device Modules, it is possible to map variables directly to I/Os of the configuration. In Mapping column of the I/O Mapping field, click the ... button to open the Select I/O Mapping dialog box and map the variable to a Channel of your I/O configuration. Confirm with OK .
8	In New Value column of the Parameters field, you can enter an initial value for the displayed variables (for example constants). If you do not enter a value, the Default value is used in your project.

NOTE: For Device Modules associated with a fieldbus, the appropriate fieldbus master has to be available in your project. For example, the Device Module `ATV32_CANopen` requires a CANopen manager in the project configuration.

Objects Added

If you add a Device Module, all associated objects are added to the project at the appropriate position. Information on what was done during adding the Device Module, is displayed in the **Messages** window.

Potential objects and actions are listed in the table.

Object	Description
root folder	A new folder is added under the Application node in the Tools tree that is named as defined in the Function Name text box in the Add Function From Template dialog box.
GVL (global variable list)	The global variable list that is included in the Device Module is added below the root folder using the Function Name . For example <code>GVL_ATV32_CANopen</code> .
POU (program organization unit)	The POU that is included in the Device Module is added below the root folder using the Function Name . For example <code>Prg_ATV32_CANopen (PRG)</code> .
POU call	The call of the POU that is included in the Device Module is added below Task Configuration → MAST using the Function Name . For example <code>Prg_ATV32_CANopen</code> .
device	A device (if included in the Device Module) is added below the respective fieldbus (for example CAN0 → CANopen_Performance (CANopen Performance)) as selected in the Select Fieldbus Master dialog box. For example <code>ATV32_CANopen (Altivar 32)</code> .
I/O mapping	Variables mapped in the Add Function From Template dialog box (I/O Mapping field), appear in the device editor of the respective device.
libraries	Libraries referenced by the Device Module are automatically added to the Library Manager of your project.

Remove Device Module

Procedure

By adding (see page 194) a Device Module, various objects are added to your project.

To remove a functional unit (based on a Device Module) from your project, you have to remove the following objects manually from your project.

Objects to be Removed

Object	Description
root folder	Remove the folder of the Device Module under the Application node in the Tools tree .
GVL (global variable list)	As the GVL is part of the root folder, it is removed with the root folder.
variables	Remove the variables coming from your Device Module and being used in the project. For example in the Symbol configuration or in the I/O mapping.
POU (program organization unit)	As the POU is part of the root folder, it is removed with the root folder.
POU call	Remove the POU call of the Device Module from Task Configuration .
device	Remove the device (if included in the Device Module) from the respective fieldbus (for example CAN0 → CANopen_Performance (CANopen Performance)).
libraries	Remove the libraries referenced by the Device Module from the Library Manager of your project (if not referenced by other objects in your project).

Section 8.2

Adapt HMI Application

Introduction

Overview

The provided HMI application is a general solution.

Since every machine needs its own specific interface, the provided HMI application will in all likelihood not match exactly your requirements. Therefore, you will need to modify the provided HMI application using the Vijeo-Designer configuration software.

Vijeo-Designer is an efficient and flexible tool. It provides numerous functions to facilitate the creation or adaptation of the HMI application.

Especially for an easy adaptation, the following features are highlighted:

- Objects can be saved as templates in tool chest.
- Placeholder in variable expressions can be used.
- Resources for object design can be used.
- Export/import function is available.
- Master panels can be used.

If desired, the provided HMI application can be used as pattern for your solution.

Chapter 9

Bill of Material (BOM)

Bill of Material (BOM)

Overview

In this chapter, a Bill of Materials (BOM) for the main components of the architecture is provided.

Components and component combinations of the protection system of this architecture are marked with additional information about the conformity to standards IEC and UL. Those which are marked as UL can be considered as a multistandard solution. Nonetheless, you must consider and respect the local standards and codes, as well as the electrical and environmental conditions, where the system is installed and operated. For more information on this topic, refer to the associated product manuals and on the Schneider Electric webpage.

Regardless of the industrial application of a control panel, its protection systems and devices must comply with applicable international standards:

- IEC 60-204 safety of machinery
- UL 508A industrial control panel

Components and component combinations that meet multiple standards are equally important to design and size for ensuring that control panels meet legal requirements across international markets.

WARNING

REGULATORY INCOMPATIBILITY

Ensure that all equipment applied and systems designed comply with all applicable local, regional, and national regulations and standards.

Failure to follow these instructions can result in death, serious injury, or equipment damage.

Schneider Electric offers UL 508A support on the website at www.Schneider-Electric.us. A number of educational and product search tools are available on the website, including overview information, a UL 508A SCCR (Short Circuit Current Rating) determination flow chart, and information on Schneider Electric individual or product combination SCCRs. Underwriters Laboratories also publish SCCR tested combination ratings on its website. Updated tested combination ratings of Schneider Electric can be found on both websites and are free to download.

The UL 508A support website of Schneider Electric is located at:

<http://www.schneider-electric.us/sites/us/en/support/product-support-resources/ul-508a-support/ul-508a-support.page>

The UL 508A combination motor controller website of UL is located at:

<http://www.ul.com/global/eng/pages/offerings/industries/powerandcontrols/industrialcontrol-equipment>

Main Switch

Quantity	Description	Reference	IEC	UL
1	PowerPact H-Frame multistandard circuit breaker, main switch, 3pin, 35 kA	NHGF36015TW	x	x
1	Lug kit 15...150 A	AL150HDS	x	x
1	Short lug shield	S37446	x	x
1	Extended rotary handle	LV429502	x	x
1	Red rotary handle on yellow bezel	LV429340	x	x

Energy meter

Quantity	Description	Reference	IEC	UL
1	Energy meter iEM3150, direct measurement up to 63 A, Modbus communication	A9MEM3150	x	x

Emergency Stop

Quantity	Description	Reference
1	Preventa safety module, stop category 0	XPSAF5130P
1	Emergency stop push-button, 2 NC, 22 mm, complete unit	XB5AS8444
1	Emergency stop push-button, complete plastic control station, yellow/ red, 2 NC	XALK178F
1	Illuminated push-button, blue, 1 NO + 1 NC, integral LED, complete unit	XB5AW36B5
1	Circular yellow legend for emergency stop push button "emergency stop"	ZBY8330
2	TeSys D contactor, AC-3 400 V / 7.5 kW	LC1D18BD

Door Guard

Quantity	Description	Reference
1	Preventa safety module, stop category 0	XPSAF5130P
1	Door guard switch	XCSPA792
1	Actuator for door guard switch	XCSZ12
1	Illuminated push-button, blue, 1 NO + 1 NC, integral LED, complete unit	XB5AW36B5
1	Plastic control station, empty, 1 cut-out, IP 66	XALD01

Display and Indicators

Quantity	Description	Reference
1	Pilot light with integral LED 24Vac/dc, white, complete unit	XB5AVB1
1	Harmony biometric USB switch	XB5S5B2L2
1	Protective cover for biometric USB switch	ZB5SZ70
1	Plastic control station, empty, 3 cut-outs, IP 66	XALD03
2	Push-button, green, 1 NO, complete unit	XB5AA31
1	Push-button, red, 1 NC, complete unit	XB5AA42
3	Legend holder and blank label (white or yellow) 18x27 mm	ZBY6102
1	Fixing plate for use on vertical support of tower light	XVBC12
1	Fixing base with support tube 80 mm, black	XVBZ02
1	Base unit for tower light	XVBC21
1	Set of 6 colored markers for the position	XVBC22
1	Signal element for tower light, green	XVBC2B3
1	Signal element for tower light, red	XVBC2B4
1	Signal element for tower light, blue	XVBC2B6
1	Signal element for tower light, clear	XVBC2B7

Automation Components

Quantity	Description	Reference
1	Distributed I/O-Module, CANopen	OTB1C0DM9LP
2	TM2 expansion module 16 DI	TM2DDI16DT
1	TM2 expansion module 16 DO (relay)	TM2DRA16RT
1	TM2 expansion module 8 DO (trans.)	TM2DDO8TT
1	TM2 expansion module analog IN (4)	TM2AMI4LT
1	TM2 expansion module analog IN/OUT (2/1)	TM2ALM3LT

Magelis HMI

Quantity	Description	Reference
1	Magelis SCU - small HMI controller for simple machines with 5.7" screen module	HMISCU8A5
1	Optional: Remote controller module connection cable, 3 m	HMIZSURDP

Control Voltage Power Supply and Distribution

Quantity	Description	Reference	IEC	UL
1	Circuit breaker Multi 9 UL1077 2P, C, 3 A (~230 V)	24444	x	x
1	Power supply 230 Vac / 24 Vdc, 10 A	ABL8RPS24100	x	x
2	Circuit breaker Multi 9 UL1077 1P, C, 1 A (24 Vdc)	24425	x	x
10	Circuit breaker Multi 9 UL1077 1P, C, 2 A (24 Vdc)	24426	x	x
1	Ground disconnect terminal 9760 U/8 TKE 48	57.110.1655.0 (Wieland)	x	x

Drives and Power

Quantity	Description	Reference	IEC	UL
Altivar 32				
2	Altivar 32 variable speed drive, 0.37 kW	ATV32H037N4	x	x
2	Magnetic circuit breaker, 2.5 A (3~400 V)	GV2L07	x	-
2	Auxiliary contacts for circuit breaker, 1 NO, 1 NC	GVAE11	x	-
2	Thermal-magnetic circuit breaker, 1.6...2.5 A (3~480 V)	GV2P07	-	x
2	Insulating barrier for motor circuit breaker	GV2GH7	-	x
* In compliance with the standard IEC 60947-2, a magnetic motor circuit-breaker can be alternatively used instead of the Multi 9 UL489 circuit breaker.				

Quantity	Description	Reference	IEC	UL
2	Auxiliary contacts for circuit breaker, 1 NO, 1 NC	GVAN11	-	x
2	CANopen communication card for daisy chain	VW3A3608	x	x
Lexium 28				
2	Lexium 28 servo drive 1~230 V/0.1 kW	LXM28AU01M3X	x	x
2	I/O terminal block module with 0.5 m (1.64 ft) cable for I/O connector CN1	VW3M1C13	x	x
2*	Magnetic circuit breaker, 6.3 A (1~230 V)	GV2L10	x	-
2*	Auxiliary contacts for circuit breaker, 1 NO, 1 NC	GVAE11	x	-
2	Circuit breaker Multi 9 UL489 2P, D, 6 A (~230 V)	60158	x	x
2	Circuit breaker Multi 9 UL1077 2P, C, 2 A (~230 V)	24443	x	x
2	Auxiliary contact for Multi 9 circuit breaker, 1 C/O	26925	x	x
2	Servo motor 230 Vac 3-phases	BCH2MB0131CA5C	x	x
2	Power cordset (motor cable), 5 m (16.4 ft)	VW3M5D1AR50	x	x
2	Encoder cordset (encoder cable), 5 m (16.4 ft)	VW3M8D1AR50	x	x
2	Adapter cable for STO connector CN9, 3 m (9.8 ft)	VW3M1C20R30	x	x
TeSys U				
1	TeSys U base module reversing; 12 A (without terminals)	LU2BA0BL	x	x
1	TeSys U control unit, standard 0.15 A...0.6 A	LUCAX6BL	x	x
1	TeSys U wiring kit coil (reversible)	LU9MRC	x	x
1	TeSys U communication module CANopen	LULC08	x	x
1	Insulating barrier for TeSys U	LU9SPO	-	x
Lexium 32i				
1	BMI servomotor with integrated power stage	BMI702P06A	x	x
1*	Magnetic circuit breaker, 4 A (3~400 V)	GV2L08	x	-
1*	Auxiliary contacts for circuit breaker, 1 NO, 1 NC	GVAE11	x	-
1	TeSys DFCC fuse holders + class CC fuses 4 A (fuses to be ordered separately - no SE product)	DFCC3	-	x
1	LXM32i control unit for CAN fieldbus	LXM32ICAN	x	x
1	Connection module supply voltage	VW3M9002	x	x
1	Connection module bus-I/O-STO	VW3M9101	x	x
1	Cable STO	VW3M9405	x	x
* In compliance with the standard IEC 60947-2, a magnetic motor circuit-breaker can be alternatively used instead of the Multi 9 UL489 circuit breaker.				

CANopen/CANmotion Wiring

Quantity	Description	Reference	
1	IP20 CANopen tap junction, 4 SUB-D ports, screw terminal block for connecting the trunk cables, line termination	TSX CAN TDM4	
1	CANopen cable, dedicated to the American market, UL and CSA certified, fire retarding	50 m (164 ft)	TSXCANCB50
4	Preformed cordset One 9-way SUB-D connector One RJ 45 connector	1.0 m (3.28 ft)	TCS CCN 4F3M1T
2	IP 20 connector CANopen female 9-way SUB-D, switch for line termination, straight		TSXCANKCDF180T
1	IP 20 connector CANopen female 9-way SUB-D, switch for line termination, 90° angled		TSXCANKCDF90T
1	IP 67 M12 connector, 5-way M12 A-coded connectors female		FTX CN 12F5
1	IP67 line terminator, Equipped with one M12 connector (for end of bus)		TM7ACTLA

Ethernet Wiring

Quantity	Description	Reference	
1	Ethernet ConneXium cable, shielded twisted-pair straight cord, one RJ45 connector at each end	2.0 m (6.56 ft)	490NTW00002
1	ConneXium M12 to RJ45 Ethernet adapter		TCSEAAF11F13F00

Modbus SL Wiring

Quantity	Description	Reference	
1	Modbus SL drop cable, 1 RJ45 connector and 1 end stripped	3.0 m (9.8 ft)	VW3A8306D30

Software Tools

Quantity	Description	Reference
1	SoMachine (includes Vijeo-Designer) on DVD	SOMNACS41*
1	Single user license for SoMachine	SOMNACCZXSPA41
1	Programming cable (USB)	BMXXCAUSBH018
1	Ethernet cable M12 - RJ45	TCSECL1M3M3S2
* The latest LXM28 add-on must be installed in addition to the SoMachine DVD separately.		



A

A coded

Connectors that have 1 raised key on the male connector and 1 mating slot on the female connector. This is the standard coding used for sensors and distribution box applications.

B

bps

(*bit per second*) A definition of transmission rate, also given in conjunction with multiplier kilo (kbps) and mega (mbps).

C

CANmotion

A CANopen-based motion bus with an additional mechanism that provides synchronization between the motion controller and the drives.

CANopen

An open industry-standard communication protocol and device profile specification (EN 50325-4).

CFC

(*continuous function chart*) A graphical programming language (an extension of the IEC 61131-3 standard) based on the function block diagram language that works like a flowchart. However, no networks are used and free positioning of graphic elements is possible, which allows feedback loops. For each block, the inputs are on the left and the outputs on the right. You can link the block outputs to the inputs of other blocks to create complex expressions.

CiA

(*CAN in automation*) A non-profit group of manufacturers and users dedicated to developing and supporting CAN-based higher layer protocols.

CSA

(*Canadian standards association*) The Canadian standard for industrial electronic equipment in hazardous environments.

D

DTM

(*device type manager*) Classified into 2 categories:

- Device DTMs connect to the field device configuration components.
- CommDTMs connect to the software communication components.

The DTM provides a unified structure for accessing device parameters and configuring, operating, and diagnosing the devices. DTMs can range from a simple graphical user interface for setting device parameters to a highly sophisticated application capable of performing complex real-time calculations for diagnosis and maintenance purposes.

E

Ethernet

A physical and data link layer technology for LANs, also known as IEEE 802.3.

EtherNet/IP

(*Ethernet industrial protocol*) An open communications protocol for manufacturing automation solutions in industrial systems. EtherNet/IP is in a family of networks that implement the common industrial protocol at its upper layers. The supporting organization (ODVA) specifies EtherNet/IP to accomplish global adaptability and media independence.

F

FBD

(*function block diagram*) One of 5 languages for logic or control supported by the standard IEC 61131-3 for control systems. Function block diagram is a graphically oriented programming language. It works with a list of networks, where each network contains a graphical structure of boxes and connection lines, which represents either a logical or arithmetic expression, the call of a function block, a jump, or a return instruction.

FDT

(*field device tool*) The specification describing the standardized data exchange between the devices and control system or engineering or asset management tools.

H

HMI

(*human machine interface*) An operator interface (usually graphical) for human control over industrial equipment.

I**I/O**

(*input/output*)

IEEE 802.3

A collection of IEEE standards defining the physical layer, and the media access control sublayer of the data link layer, of wired Ethernet.

IL

(*instruction list*) A program written in the language that is composed of a series of text-based instructions executed sequentially by the controller. Each instruction includes a line number, an instruction code, and an operand (refer to IEC 61131-3).

IP 20

(*ingress protection*) The protection classification according to IEC 60529 offered by an enclosure, shown by the letter IP and 2 digits. The first digit indicates 2 factors: helping protect persons and for equipment. The second digit indicates helping protect against water. IP 20 devices help protect against electric contact of objects larger than 12.5 mm, but not against water.

IP 67

(*ingress protection*) The protection classification according to IEC 60529. IP 67 modules are protected against ingress of dust, contact, and water up to an immersion depth of 1 m.

L**LD**

(*ladder diagram*) A graphical representation of the instructions of a controller program with symbols for contacts, coils, and blocks in a series of rungs executed sequentially by a controller (refer to IEC 61131-3).

M**Modbus**

The protocol that allows communications between many devices connected to the same network.

Modbus SL

(*Modbus serial line*) The implementation of the protocol over a RS-232 or RS-485 serial connection.

P**POU**

(*program organization unit*) A variable declaration in source code and a corresponding instruction set. POU's facilitate the modular re-use of software programs, functions, and function blocks. Once declared, POU's are available to one another.

Profibus DP

(Profibus decentralized peripheral) An open bus system uses an electrical network based on a shielded 2-wire line or an optical network based on a fiber-optic cable. DP transmission allows for high-speed, cyclic exchange of data between the controller CPU and the distributed I/O devices.

R

RJ-45

A standard type of 8-pin connector for network cables defined for Ethernet.

RS-232

A standard type of serial communication bus, based on 3 wires (also known as EIA RS-232C or V.24).

RS-485

A standard type of serial communication bus, based on 2 wires (also known as EIA RS-485).

S

SFC

(sequential function chart) A language that is composed of steps with associated actions, transitions with associated logic condition, and directed links between steps and transitions. (The SFC standard is defined in IEC 848. It is IEC 61131-3 compliant.)

SoMachine

A comprehensive controller development system software tool for configuring and programming the Modicon logic controller and devices compliant with IEC 61131-3.

ST

(structured text) A language that includes complex statements and nested instructions (such as iteration loops, conditional executions, or functions). ST is compliant with IEC 61131-3.

T

TVDA

(tested validated documented architectures) Control system proposals based on Schneider Electric components. TVDAs cover a wide range of machine types and consider machine performance requirements, installation constraints, and target costs. To optimize the implementation effort, each TVDA comes with a detailed component list, wiring diagrams, and commissioning guide, as well as controller and HMI applications to control components of the system.

V**VSD**

(variable speed drive) An equipment that makes a variable and regulates the speed and rotational force, or torque output, of an electric motor.



C

Compact CANopen SCU HMI Controller
system architecture, 24

TVDA SCU HMI CANopen
bill of material (BOM), 199

H

HMI application
TVDA, 189

S

SCU HMI CANopen
SUG, 11
TVDA, 11
setup devices
TVDA, 173
SUG (system user guide)
SCU HMI CANopen, 11
system setup
TVDA, 173
system user guide (SUG)
SCU HMI CANopen, 11

T

template
TVDA, 157
template, adapt
TVDA, 189
TVDA
adapt template, 189
communication, 123
hardware, 59
HMI application, 189
implementation, 157
safety requirements, 27
SCU HMI CANopen, 11
setup devices, 173
template, 157
wiring, 123

